

Racor Products

Parts, Service and Technical Information

Global Filtration
Technology



RACOR
Parker
Filtration



- 1 Heavy Duty Products Filtration Products
- 2 Marine Fuel Filtration Products
- 3 Recycling & High Flow Filtration Systems
- 4 Interceptor Filter Products

- 5 Lubrication Filtration Systems
- 6 Alternative Fuel Filtration Systems
- 7 Crankcase Ventilation Filter Systems
- 8 Engine Air Filters

- 9 Additives
- @ email Parker UK
- W www.parker.com
- ? Help & General Information

Racor Products

Section 1 Heavy Duty Products

On-Off Highway

- Selection
- Diesel Spin On
- 100/200
- 300
- 300RC
- 400
- 600
- Turbine
- 500
- 900
- 1000
- 73/1000
- 75/500
- 75/900
- 75/1000
- 77/1000
- 79/1000
- Diesel Fuel Heaters
- Accessories
- Fittings



Help & General
Information

SELECTION - SECTION 1

DIESEL, KEROSENE AND GASOLINE FUEL FILTERS:

1. Find the **application**: Diesel #2, Kerosene or Gasoline.
2. Find the **installation**. Will the unit be installed on the suction (vacuum) or pressure side of the fuel pump? Racor units are most efficient when installed on the suction side of the fuel system. If the filter is a replaceable engine spin-on type, go directly to the 320 Engine Spin-on Series.
3. Find the **fuel flow rate**. **You should obtain this information from your engine or equipment manufacturer or your Racor dealer.** Use this information to select a Racor filter that has a greater flow rating than your equipment's total fuel flow rate.

If this information is not available use the following formula for estimating.

Diesel or kerosene fuel systems:

Gallons per Hour is Engine Horsepower (maximum) multiplied by 18% or $GPH = HP \times 0.18$

Gasoline fuel systems (carbureted):

Gallons per Hour is Engine Horsepower (maximum) multiplied by 10% or $GPH = HP \times 0.1$

Gasoline fuel systems (fuel injected):

Use a straight 40 GPH figure.

4. What other conditions apply?

Will operations be in cold climates? An internal fuel heater may be needed for diesel (or kerosene) applications to reduce fuel gelling. Heaters are available with most models listed. For continuous, full-time heating see the 345RC, 360RC, & 390RC Series and the 6400 Series.

Water contamination. A water detection package should be added to inform the operator of water build-up and necessary servicing. Water detection packages are available for use with all models in diesel fuel applications, only.

Does the engine need to run continuously, not allowing a shut-down for needed servicing, such as a generator? If so, see 'Turbine' models with the '75, or 79' prefix in the part number.

What type of filter element best suits your vehicle? The 'Turbine' series have element cartridges that are serviced from the top and all other units in this section have a removeable spin-on type canister that is serviced from the bottom.

A convenient feature may be a priming pump. For manual hand operated pumps, see the 200 and 400 Series and the model 6120N. For electric priming pumps, see the RP and Integrated Series.

5. **With the above information, review the models suggested that best fit your installation.** Most of the Model Groups have additional information to help in identifying the exact model for your needs. Call your Racor distributor or Racor customer service if you need additional assistance at: (800) 344-3286, or e-mail us from our website at www.parker.com/racor.

DIESEL AND KEROSENE FUEL SYSTEM HEATERS:

1. Go directly to the Diesel Fuel Heaters Section for specific selection information.

DISCONTINUED MODELS:

Occasionally, models may be superseded by new products. The 130R, 200FG and 200 Series were superseded by the 215R, 230R and 245R Series. The 6100 was superseded by the 6400 Series.

1. Go directly to the Discontinued Models Section for available parts information.
-

Selection Information

General

The Racor Diesel Spin-On Series feature a variety of compact sizes to fit in the most cramped engine compartments.

Mounting Heads:

These units all feature 1/4" NPTF ports and many have more than one inlet or outlet. All have a unitized mounting bracket except the 140R which may be 'hard piped' and supported by the piping.

Filters:

All units feature spin-on replaceable filters and contaminant collection bowls except for the high-pressure 110A. All units may be specified with an in-bowl water probe when used with diesel or kerosene applications. Danger! Do not use in-bowl water probes with gasoline applications. This may cause an explosion.

High-capacity Aquabloc™ filter elements, which stop water and remove solid contamination, are available in 2, 10 or 30 micron with most models. Equipment owners can specify their filtration needs based on application, fuel quality, operating climates and maintenance schedules.

A 30 micron filter (or primary filter) is used to filter raw fuel (or poor quality fuel) before it can be further filtered by finer medias such as a 10 or 2 micron. A 10 micron filter (or secondary and even final) is used to filter fuel which is known to be of very good quality. A 2 micron filter (or final filter) is the finest filtration available and is the last filter used prior to engine ingestion.

A simple rule to remember is the finer the filtration, the more frequent the filter change. (*Carry extra filters with your equipment*).

Reusable Collection Bowls:

The see-thru bowls used with these models won't discolor from alcohol, additives or UV light and have a leak-proof, positive seal drain for easy service. Water and contaminant levels can be seen easily at a glance. Metal bowls are also available and should be specified when filtering fuels in hazardous locations where equipment is exposed to flying gravel and debris.

Options -Available for Diesel fuel systems only.

Water Probe RK21069. All units may be ordered with an in-bowl water probe to alert the operator of a high-water condition, even while the equipment is operating. The bowl is then drained of water at the earliest convenience. Note: A Racor Water Detection Module is needed to work with this probe. See Accessories.

Water probe RK30880 has the same features as above, except the 12 or 24 vdc electronic detection module is built into the probe housing and includes a detachable connector. See Accessories. Danger! Do not use in-bowl water probes with gasoline applications. This may cause an explosion.

Fuel Heater. The 215R, 230R, and 245R units may be ordered with an in-bowl 200 watt, thermostatically controlled resistance heater. This design places the heat source directly below the element to maximize heat transfer. Note: An additional relay (or relay kit) may be needed to operate the fuel heater. See Accessories.

SELECTION

1. Along with the information you obtained in SECTION 1, SELECTION (page 2), consider the following: Are there any space limitations in the available location? The location should provide adequate space for removing the element, draining off contaminants from the bowl (and operating the primer pump on those applicable models).
2. What filtration rating is needed? 2, 10 or 30 micron?
3. What options are needed? Priming pump, water probe and/or an in-bowl heater?

Using this information, select a unit from the next page, or check the models which follow to find the right unit for your application.

For additional information, call your Racor dealer or call Racor customer service at (209) 521-7860 or (800) 344-3286, 6:00 AM to 5:00 PM, Pacific Time, or e-mail us from www.parker.com/racor.

Model Illustrations

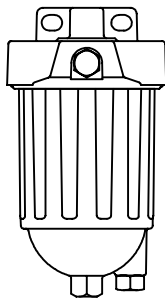

110A

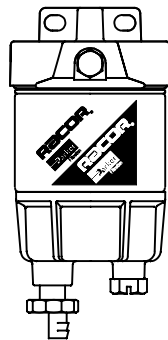

120A / 120B
(120A shown)

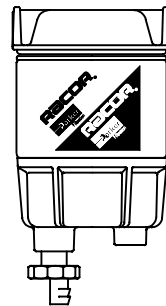

140R

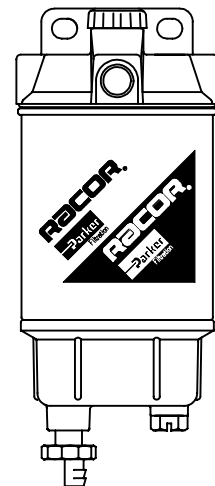

215R / 230R / 245R
(245R shown)

Special Notes

1. All units should be installed on the suction (vacuum) side of the fuel or transfer pump for best efficiency.
2. Models 110A, 215R, 230R and 245R may be used on suction OR pressure side applications.
3. Allow at least 2 inches (51 mm) clearance under the units for replacement of element and water collection.
4. For additional information and availability, contact customer service at: (800) 344-3286, Pacific Time, or e-mail from our website, www.parker.com/racor.

Specifications

BASIC MODELS		110A	120A / 120B	140R	215R / 230R / 245R
Maximum Flow Rate	GPH LPH	15 57	15 / 20 57 / 80	15 57	15 / 30 / 45 57 / 114 / 170
Port Size, NPTF	(SAEJ476)	1/4"-18	1/4"-18	1/4"-18	1/4"-18
Service Filter Element Center Threads		R11 N/A	R12 / R13 Series M18 X 1.5	R12 Series M18 X 1.5	R15 / R20 / R25 1"-14
Height	in. mm	6 152	6.5 / 8.0 166 / 203	6 152	8.3 / 9.0 / 10.5 211 / 229 / 267
Width	in. mm	3.2 81	3.2 81	3.2 81	4 102
Depth	in. mm	3.2 81	3.2 81	3.2 81	4 102
Weight (dry)	Lbs. kgs.	1.3 .59	1.1 / 1.2 0.5 / 0.6	1.1 .50	1.8 / 2 / 2.2 .80 / .90 / 1.0
Clean Element Pressure Drop	PSI kPa	0.15 1.03	0.15 / 0.15 1.03 / 1.03	0.01 0.07	0.12 / 0.31 / 0.61 0.83 / 2.14 / 4.21
Maximum Allowable Pressure	PSI / kPa	100 / 689	7 / 48	7 / 48	30 / 207
Bowl Water Capacity to probe tips (with heater)	ml ml	36 NA	52 NA	52 NA	58 48
Operating Temperature		- 40° / +255° F / - 40° / +121° C			

Diesel Spin-On Series

Model 110A

SPECIFICATIONS are found on Spin-On Series introduction page.

110A	Replacement Service Element <i>SERVICE ELEMENT INCLUDES LID SEAL.</i>
Basic Model 15 GPH. Two piece die-cast aluminum construction	R11T 10 Micron -Recommended for Primary or Secondary* Filtration <i>*Consult engine manufacturer or Racor Distributor.</i>

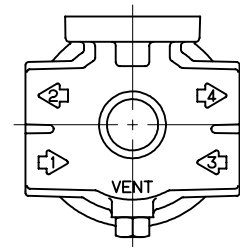

Mounting Hole Pattern -Refer to Diesel Spin-on Series introduction page for filter dimensions.

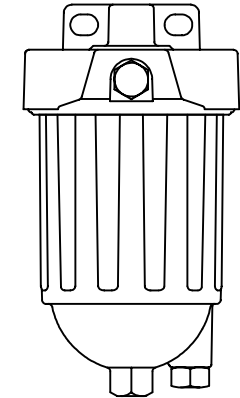
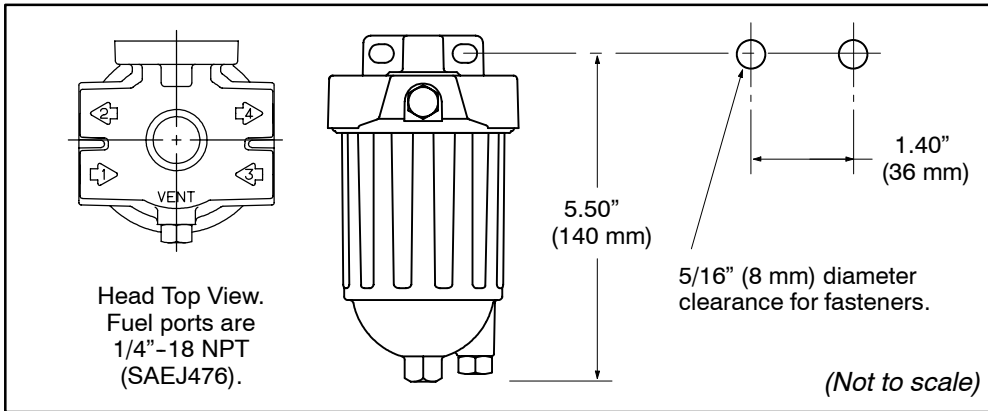

110A

Performance Graphs These results are from controlled laboratory tests. Field results may vary by application.

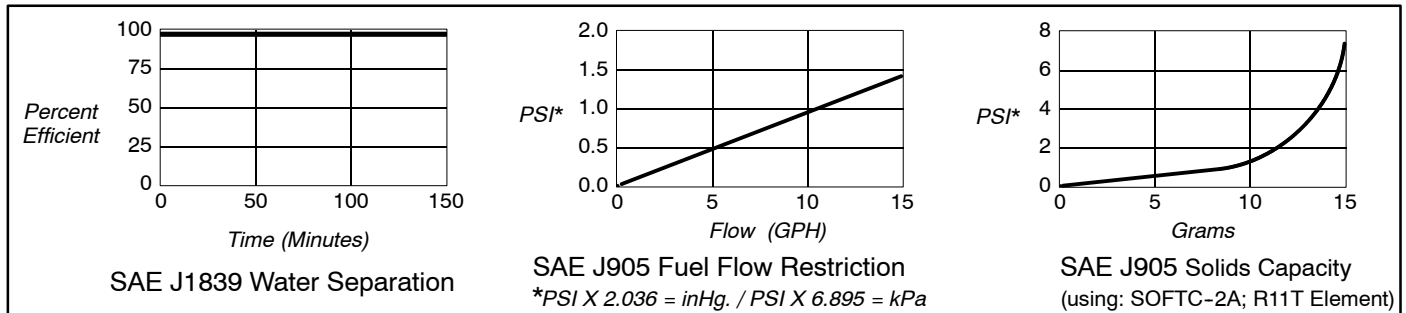

Parts List The circled number corresponds to the item number shown in the parts list below.

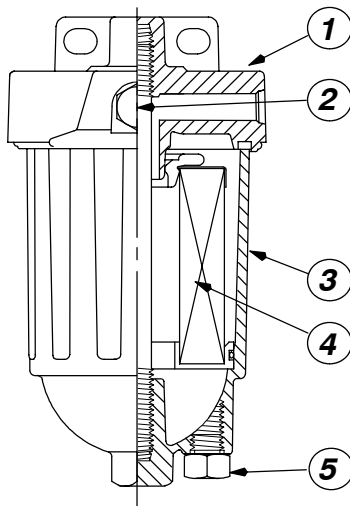

Item/Part No.	Description	Case Qty.
1 RK21361	110A Head, 1/4"NPTF Ports	1
2 RK10110	Metal Vent Plug, 3/8"-24	1
3 RK21364	110A Housing	1
4 R11T	Service Element, 10 micron	12
5 RK20022	Metal Plug, 1/2"-20	1
RK30817	Port Plug Kit, 1/4" NPT	1
RK21363	110A Gasket/O-ring Kit	1
21410	Installation Instructions, 110A	

SPECIFICATIONS are found on Spin-On Series introduction page.

120A	S
120A = 15 GPH 120B = 20 GPH Vent plug in the head is standard.	<u>Element Filtration Rating.</u> Specify: 'S' for 2 micron (secondary/final filtration) 'T' for 10 micron (ten micron for severe service) 'P' for 30 micron (primary filtration).

Replacement Service Elements Service element includes seals.

Model	Final Filtration	Secondary Filtration	Primary Filtration*
	2 Micron	10 micron	30 micron
120A	R12S	R12T	R12P
120B	R13S	R13T	R13P

*A secondary/final filter is required downstream.



Performance Graphs Results are from controlled laboratory tests. Field results may vary.

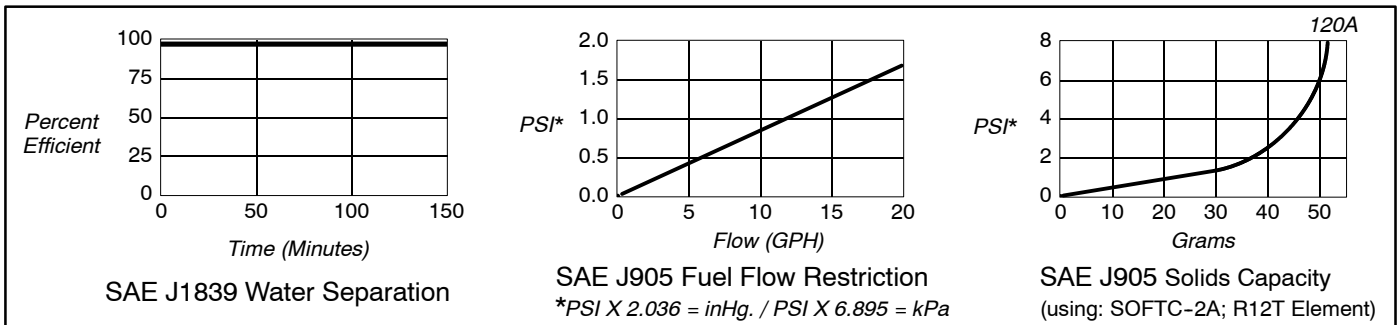

Mounting Pattern / Parts List

(Not to scale)

-Refer to Diesel Spin-on Series introduction page for filter dimensions.
-The circled number corresponds to the item number shown below.

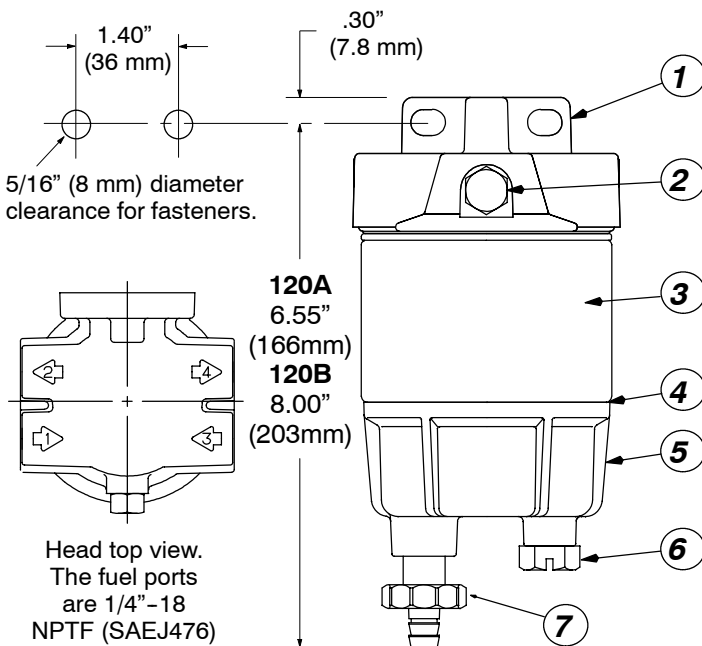

Item/Part No.	Description	Case Qty.
1	RK10214 Head, 1/4" NPTF Ports	1
2	RK10110 Metal Vent Plug, 3/8"-24	1
3	R12S 120A Service Element, 2 micron	20
	R12T 120A Service Element, 10 micron	20
	R12P 120A Service Element, 30 micron	20
	R13S 120B Service Element, 2 micron	20
	R13T 120B Service Element, 10 micron	20
	R13P 120B Service Element, 30 micron	20
4	RK10012 Bowl O-ring	1
5	RK10215 See-thru Bowl/Drain/Plug Assembly	1
	RK10109 Metal Bowl Kit	1
6	RK20126 Plastic Plug, 1/2"-20 SAE	1
	RK30964 ¹ Water Probe and Connector (not shown)	1
7	RK30476 Drain Valve Assembly	1
	10219 Installation Instructions, 120A Series	

¹ Must be used with a Water Detection Kit -See Accessories.

SPECIFICATIONS are found on Spin-On Series introduction page.

140R	Features
<p><u>Basic Model</u> 15 GPH. Call factory for available micron ratings and options not listed.</p>	<p>The 140R is standard with 1/4"-18 NPT (SAEJ476) ports, a 10 micron element and a see-thru bowl. The in-line head is designed for applications that do not require a mounting bracket.</p>

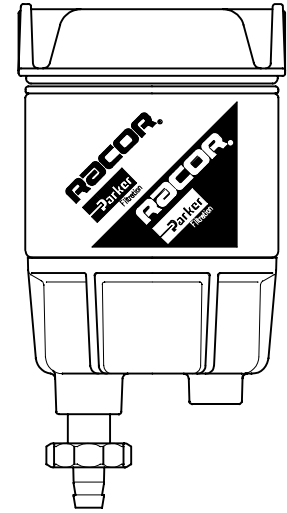

140R

Replacement Service Element -Service Element Includes Seals.

R12S	2 Micron -For Secondary (Final) Filtration
R12T	10 Micron -For Severe Service Filtration
R12P	30 Micron -For Primary Filtration*
	*A secondary/final filter is required downstream.

Performance Graphs -These results are from controlled laboratory tests. Field results may vary.

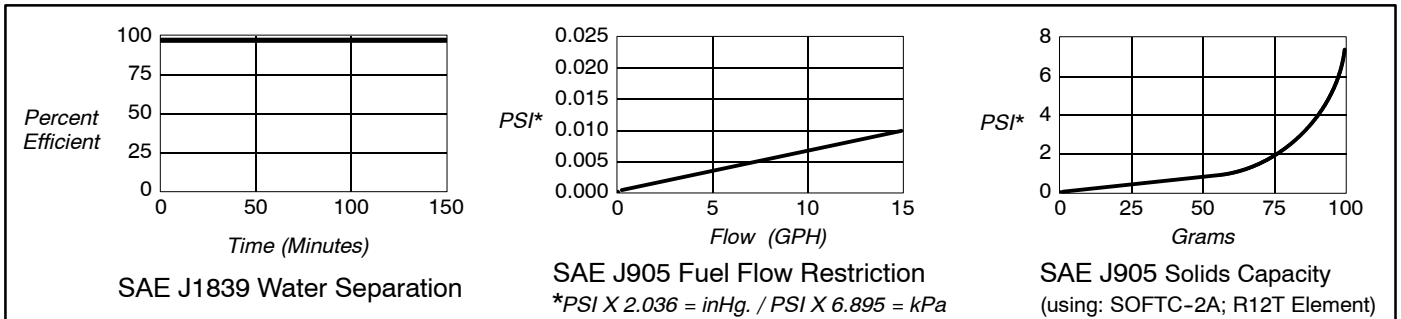

Parts List - The circled number corresponds to the item number shown in the parts list below.

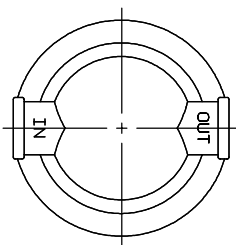

Head top view.
Fuel ports are:
1/4"NPTF
(SAEJ476)

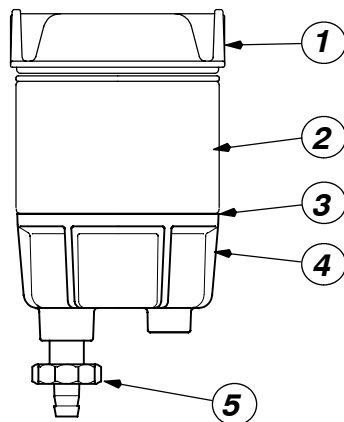

Item/Part No.	Description	Case Qty.
1	RK10177 140 Head, 1/4"-18 NPTF Ports	1
2	R12S 2 micron Replacement Element	12
	R12T 10 micron Replacement Element	12
	R12P 30 micron Replacement Element	12
3	RK10012 Bowl O-ring	10
4	RK10193 See-thru Bowl/Drain/Plug Assy.	1
5	RK30476 Drain Valve Assembly	1
	10192 Installation Instructions, 140R Series	

Diesel Spin-On Series

Models 215R, 230R, 245R

SPECIFICATIONS are found on Spin-On Series introduction page.

Note: to order a unit with metric threads, specify an asterisk (*) in front of the part number.

230R	M	P	12	2
215R= 15 GPH 230R= 30 GPH 245R= 45 GPH	<u>Metal Bowl.</u> Add 'M' (Omit if not desired)	<u>Water Probe.</u> ¹ Add 'P' for an in-bowl water probe. (Omit if not desired)	<u>200 watt Electric Heater.</u> ² Specify: '12' for 12 vdc or '24' for 24 vdc in-bowl heater. (Omit if not desired)	<u>Element Filtration Rating.</u> Specify one: '2', '10' or '30'
¹ Head fuel ports are 1/4"-18NPT (SAEJ476). Includes in-head primer pump. ² Must be used with Water Detection Kit -See Accessories Section. ² Recommended for use with Racor Relay Kit -See Accessories Section.				

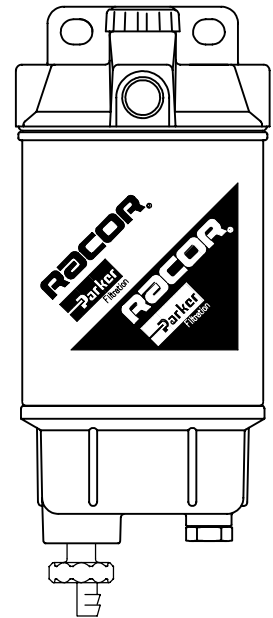

245R shown

Replacement Service Elements 12/Case -Seals included.

Model	Final Filtration 2 Micron	Secondary Filtration 10 micron	Primary Filtration* 30 micron
215R	R15S	R15T	R15P
230R	R20S	R20T	R20P
245R	R25S	R25T	R25P

*A secondary/final filter is required downstream.

Performance Graphs -These results are from controlled laboratory tests. Field results may vary by application.

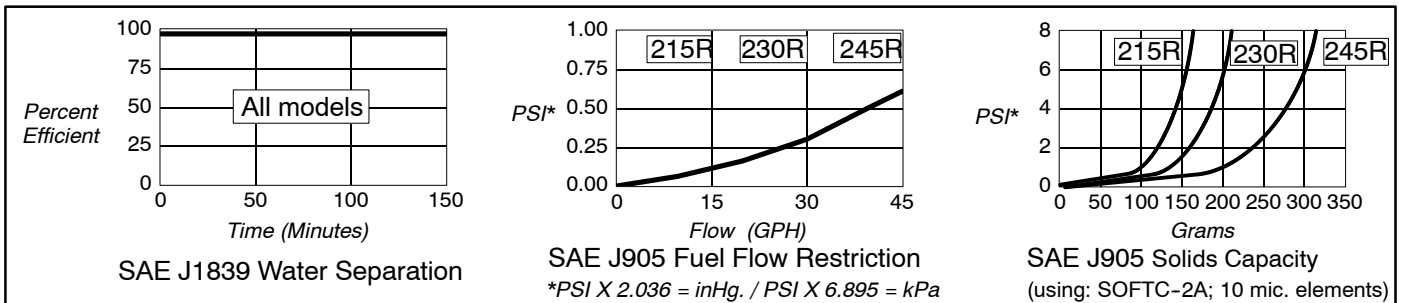

Mounting Pattern / Parts List -The circled number corresponds to the item number shown below.

5/16" (8 mm) diameter clearance for fasteners.

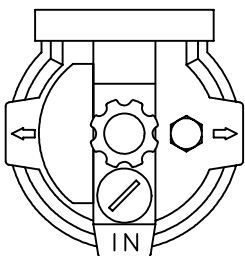
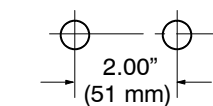

Head top view.
Fuel ports are 1/4"-18 NPT (SAEJ476)

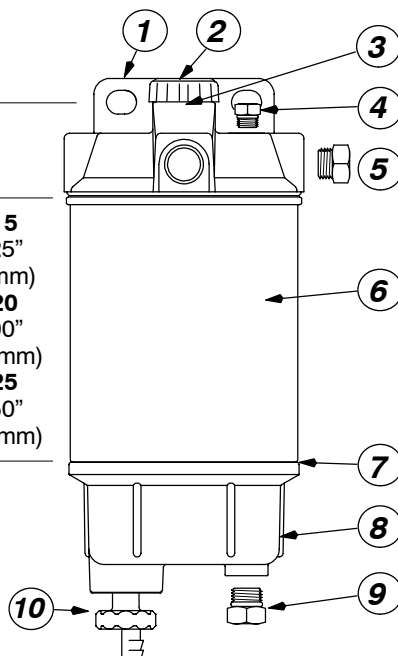

Item/Part No.	Description	Case Qty.
1 RK20046	Head, 1/4"-18 NPTF Ports	1
RK20049	Head, 14 mm X 1.5 Metric ports	1
2 RK20025	Primer Pump Assembly	1
3 RK20011	Check Ball and Plastic Cap	1
RK20742	Metal Check Ball Cap	1
4 RK10110	Metal Vent Plug, 3/8"-24 SAE	1
5 RK12041	Metal Port Plug, 1/4"-18 NPT	1
6	See 'Replacement Service Element' box above.	
7 RK22244	Bowl O-ring	20
8 RK22350-02	See-thru Bowl Assembly w/ Plug	1
RK22354-01	12vdc Heater and See-thru Bowl	1
RK22354-02	24vdc Heater and See-thru Bowl	1
RK30499-01	12vdc Heater and Metal Bowl	1
RK30499-02	24vdc Heater and Metal Bowl	1
RK30876	Heater Connector Replacement	1
RK22368	Metal Bowl (drain/probe ports)	1
9 RK20022	Metal Plug, 1/2"-20 SAE	1
RK20126	Plastic Plug, 1/2"-20 SAE	1
RK30964 ¹	Water Probe/Connector(not shown)	1
10 RK30476	Self-venting Drain Kit	1
RK20075	Complete Gasket/O-ring Kit	1
22360	Installation Instructions, 200 Series	

¹ Must be used with a Water Detection Kit -See Accessories.

Diesel Engine Spin-On Series

Service Elements

See facing page for optional mounting heads and contaminant collection bowl kits.

All Racor replacement service elements meet OEM specifications.

Bowl supplied with part numbers that have a 'B' prefix. No water probe port on bowls.

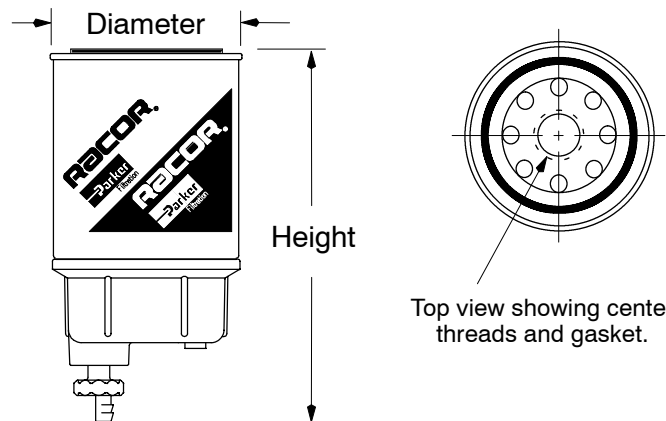

Specification/Cross Reference Chart

Filter & Bowl	Filter only	Height in./mm	Diameter in./mm	Center threads	OEM	AC	Baldwin	Fleetguard	Fram	Purolator	Wix
B32001	S3201	10.50/267	3.82/97	1"-14	Cum 138627 Cum154709 Cum 202893 Cum 156172	TP-619 TP-629 TP-972 TP-811	BF-948 BF-948D BF-957 BF-957D BF-7557	FS1212 FF104 FF105 FF105C /D FF213	P1101PL	PER15 6683776 PER23-1 PER23-2 6694036	33107
B32002	S3202	10.50/267	3.82/97	1"-12	DDA6438839	T-815 T-915	BF-580	FS1213 FF207	P1146	PER96	33118
B32003	S3203	8.63/219	3.82/97	1"-14	Cat 6L7440 Cat 1P2299 Cum138627 IH625627C1	TP-877 TP-619	BF-970 BF-957 BF-979	FF5020 FS1214 /15 FS1212 /25 FS185 /04	P1104 P1101PL P1118	PER53 PER15 PER39 PER35	33352 33107 33341
B32004	S3204	7.13/181	3.82/97	1"-14	IH625625C1	TP-807	BF-984	FS1220 FF196	P1117 P3767	PER35	33239
B32005	S3205	9.75/248	4.38/111	13/16" -18	Mack 483GB219A	TP-635	BF-877	FS1219 FF172	F1109	PER31	33219
B32006	S3206	12.00/305	4.38/111	1"-14	Cat4N5823	TP-920	BF-584	FS1218 FF211	P3376	PER85	33384
B32007	S3207	13.50/343	5.09/129	1 1/4" -12	Cum299202	TP-917	BF-596	FS1216 FF202	P3430	PER134	33116
B32008	S3208	7.25/184	2.85/72	16mm X 1.5, S=2 micron, T=10 micron, P=30 micron, 72mm gasket	Deutz Q1H4117 Volvo 243004	TP-961	BF-993	FF1221 FF202	P4102	PC-42	336P 33195
B32009	S3209	8.63/219	3.82/97	16mm X 1.5, 72mm gasket	Mann WK962/4 DAF 247138			FF4070	P4107	PC-45	33449
B32011	S3211	8.63/219	3.82/97	1"-14	Cat 6L7440 Cat 1P2299 Cum138627 IH625627C1	TP-877 TP-619	BF-970 BF-957 BF-979	FF5020 FS1214 /15 FS1212 /25 FS185 /04	P1104 P1101PL P1118	PER53 PER15 PER39	33352 33107 33341
B32012	S3212	7.13/181	3.82/97	1"-12	GM/DDC 8.2L, 30 micron, 90 GPH, 12/Case	TP-936	BF-592	FF235	P3594	PER227F	33121
B32016	S3216	5.85/149	2.85/72	16mm X 1.5, S=2 micron, T=10 micron, P=30 micron 72mm gasket							33392
B32022	S3222	10.50/267	3.82/97	1"-14	Thermo King Primary Filtration				PS7210		
N/A	S3229	10.23/260	3.82/97	1"-12	10 micron, 90 GPH, 12/Case						

(Specification/Cross Reference Chart continued on next page)

Specification/Cross Reference Chart (continued)

Filter & Bowl	Filter only	Height in./mm	Diameter in./mm	Center threads	OEM	AC	Baldwin	Fleetguard	Fram	Purolator	Wix
B32030 S3230 Application: Blue bird, 30 mic., 60 GPH, 12/Case		8.63/219	3.82/97	1"-14	4309159						
B32033 S3233 Application: 2 micron, 60 GPH, 12/Case		7.50/191	4.25/108	7/8"-14"	Cat 9Y4425	TP862	BF588	FF182	P1107	6680518	33237

FUEL FILTER MOUNTING HEADS

The mountable filter heads shown below may be used with many of the diesel engine spin-on series fuel filter/water separator elements listed on the next page. Follow the table for selection.

Head Part No.	Center Threads	Inlet / Outlet	Vent Port	Use With the Following Units
RK30287	1"-14	7/8"-14 SAEJ1926 O-ring Boss Ports	Not Available	B32001/S3201, B32003/S3203 B32004/S3204, B32006/S3206 B32011/S3211, B32022/S3222
RK31547	1-1/4"-12	7/8"-14 SAEJ1926 O-ring Boss Ports	3/4"-16 SAEJ1926 O-ring Boss Ports	B32007 / S3207

RK30287 Filter Head, Fasteners and Mounting Bracket

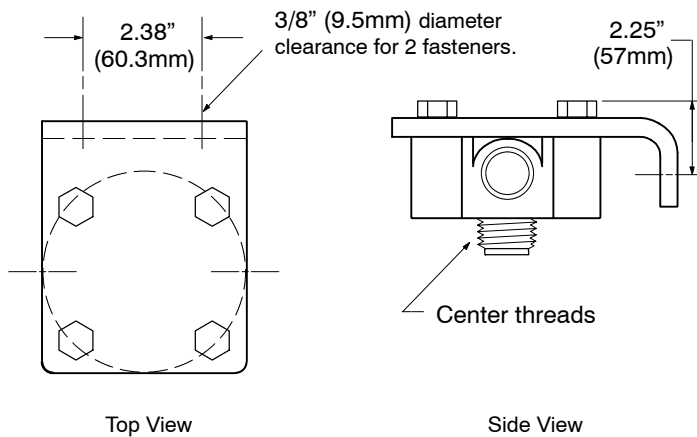

RK31547 Filter Head/Mounting Flange (not to scale)

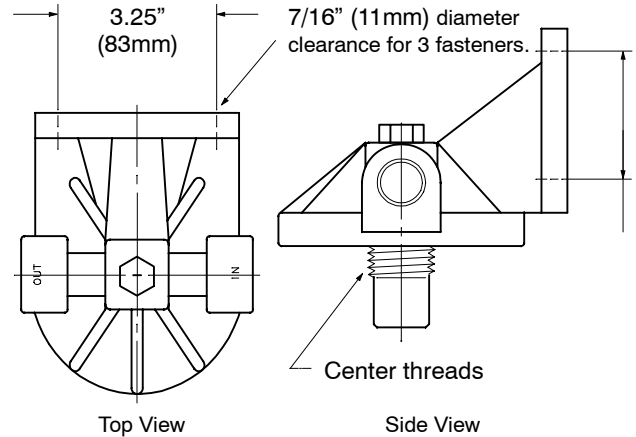

FUEL FILTER COLLECTION BOWLS

These spin-on, reusable contaminant collection bowls shown below may be used with many of the diesel engine spin-on series fuel filter/water separator elements listed on the next page. All bowls feature a water probe port unless noted.

See-thru Non-Heated Replacement Bowl Kits:

- RK10215 for 2.85" diameter filters (see style A).
- RK30051 for 3.82" diameter filters (see style C).
- RK30063 for 4.38" and 5.09" diameter filters (see style D).

See-thru Heated Replacement Bowl Kits:

- RK30895* for 3.82" diameter filters, 12 vdc, 200 watt (see style C).
- RK30924* for 3.82" diameter filters, 24 vdc, 200 watt (see style C).
- RK30900 for 4.38" and 5.09" diameter filters, 12 vdc, 200 watt (see style D).
- RK30925 for 4.38" and 5.09" diameter filters, 24 vdc, 200 watt (see style D).

Metal Non-Heated Replacement Bowl Kits:

- RK10109 for 2.85" diameter filters, non-painted (see style B).
- RK30745-01 for 3.82" diameter filters, painted beige (see style C).
- RK21640 for 4.38" diameter filters, non-painted (see style D)

* Does not feature a water probe port.

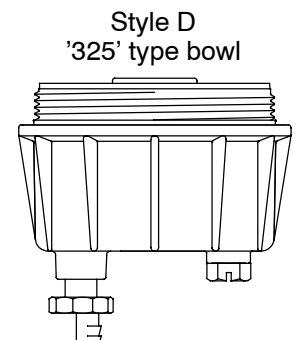
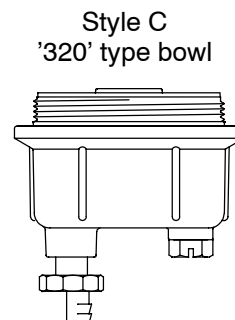
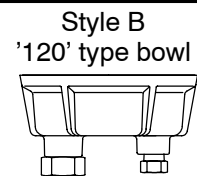
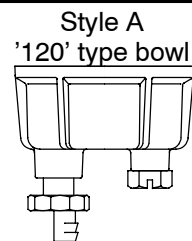

Model Illustrations

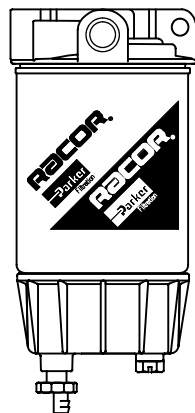

325R



330R

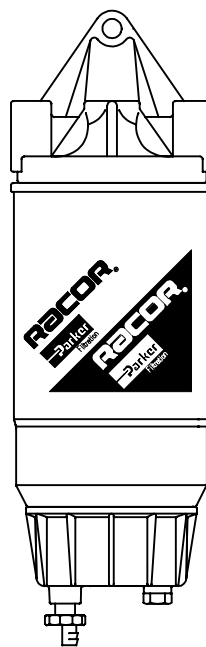

3150R

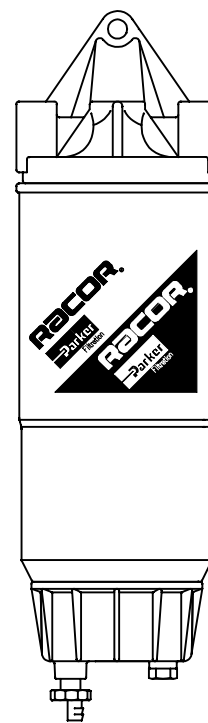

3250R

Special Notes

1. The 325R/330R models are standard with a 12 vdc, 150 watt heater. Options include a Water Probe and Element Restriction Detection Kit which alerts the operator when water must be drained or element restriction reaches 7 inHg.
2. The 3150R/3250R may be used with an optional in-bowl water probe or 200 watt, in-bowl heater (See accessories).
3. Allow at least 2 inches (51 mm) clearance under the units for replacement of element and water collection.
4. For additional information and availability, contact customer service at: (800) 344-3286, 6 AM to 5 PM, Pacific Time.

Specifications

BASIC MODELS		325R	330R	3150R	3250R
Maximum Flow Rate	GPH / LPH	60 / 227	75 / 284	150 / 568	250 / 946
Fuel Port Size		3/8"-18 NPTF (SAEJ476)	3/8"-18 NPTF (SAEJ476)	7/8"-14 SAE (SAEJ1926)	7/8"-14 SAE (SAEJ1926)
Service Filter Element Center Threads	SAE	S3225T or P 1"-14	S3226T or P 1"-14	S3238 1"-14	S3207 1"-14
Height	in. / mm	9.7/246	11/279	13.63/346	17.25/438
Width	in. / mm	4.4/112	4.4/112	5.00/127	5.00/127
Depth	in. / mm	4.8/122	4.8/122	5.5/140	5.50/140
Weight (dry)	Lbs. / kgs.	3.1/1.4	3.2/1.45	3.6/1.63	4.6/2.08
Clean Element Pressure Drop	PSI / kPa	0.17/1.2	0.39/ 2.7	.68/4.7	1.0/6.9
Max. Allowable Pressure	PSI / kPa	15/103	15/103	7/48	7/48
Bowl Water Capacity to probe tips	ml	82	82	82	82
(with heater)	ml	70	70	70	70
Operating Temperature		-40° / +255°F / -40° / +121°C			

Diesel Spin-On Series

Models 325R, 330R

SPECIFICATIONS are found on Spin-On Series introduction page.

How to Order -The example below illustrates how part numbers are constructed.

325R	P	12	-10
325R: 60 GPH / 227 LPH 330R: 75 GPH / 284 LPH	<u>Water Probe and Element Restriction Kit.</u> Add 'P' (Omit if not desired).	Standard 12 vdc, 150 watt Electric In-head Heater. <i>'12' must be in the part number.</i>	<u>Element Filtration Rating.</u> Specify: '10' for 10 micron or '30' for 30 micron

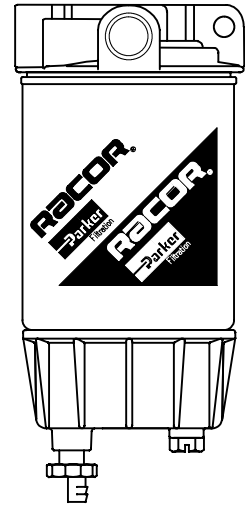

325R shown

Replacement Service Elements -10/Case -Element seals included.

Model	Secondary Filtration	Primary Filtration*
	10 micron	30 micron
325R	S3225T	S3225P
330R	S3226T	S3226P

*A secondary/final filter is required downstream.

Mounting Pattern / Parts List The circled number corresponds to the item number shown below.

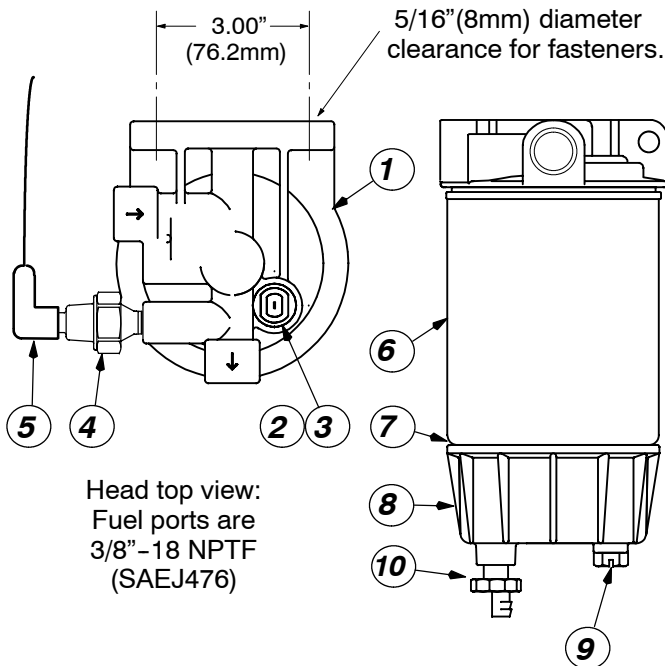

Item/Part No.	Description	Case Qty.
1	RK22724 Mounting Filter Head	1
	RK30765 Head with Vacuum Switch Port	1
2	RK22010 12 vdc, 150 watt In-Head Heater	1
3	RK20366 Heater Connector (not shown)	1
4	RK20163 Vacuum Switch (preset at 7 in.Hg.)	1
5	RK21030 Vacuum Switch Connector	1
6	See 'Replacement Service Element' box above.	
7	30965 Bowl Gasket (not shown)	1
8	RK30063 See-thru Bowl/ Wtr.Snsr.Port Plug	1
9	RK20126 Water Probe Port Plug	1
	RK21069 Water Probe (not shown)	1
10	RK30476 Drain Valve and Seal	1
	RK30803 Assy. Seal Service Kit (not shown)	1
	30762 Installation Instructions, 325R/330R Series	

Performance Graphs -These results are from controlled laboratory tests. Field results may vary.

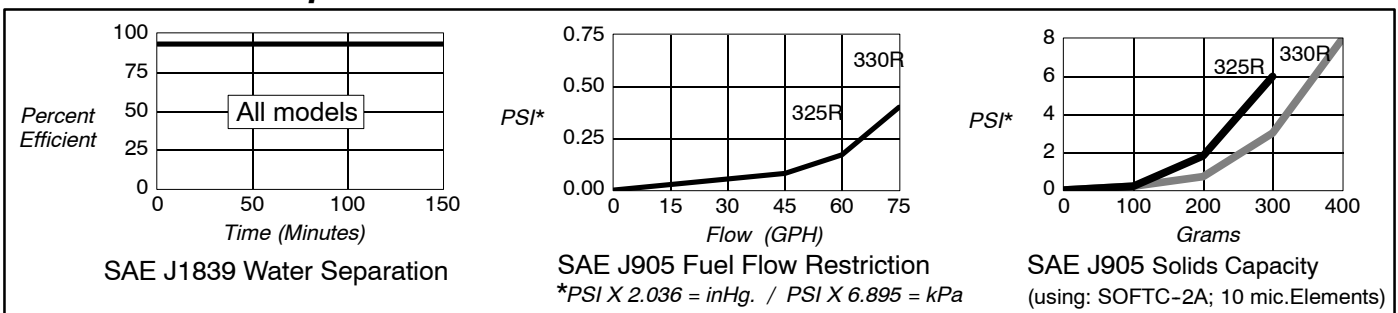

Diesel Spin-On Series

Models 3150R, 3250R

1

SPECIFICATIONS are found on Spin-On Series introduction page.

How to Order -The example below illustrates how the part numbers are constructed.

3150R, 3250R	Features
3150R: 150 GPH/568 LPH 3250R: 250 GPH/946 LPH Ideal for high-flow applications that require low restriction values.	The beige coated filter head is standard with 7/8"-14 SAE O-ring (SAEJ1926) inlet and outlet ports and also includes a large 3/4" SAE port for fuel priming. The spin-on replaceable element is rated at 10 microns and the spin-on reusable contaminant collection bowl features a self-venting drain.

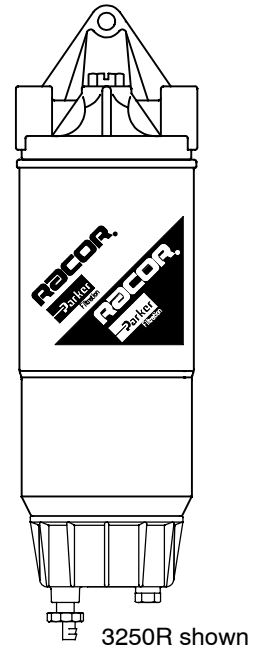

Replacement Service Elements 6/Case -Seals included.

3150R: S3238	- 10 micron Aquabloc media for primary or secondary filtration.
3250R: S3207	- 10 micron Aquabloc media for primary or secondary filtration.

Mounting Hole Pattern / Parts List -Refer to the series introduction page for more information.

3/8" (10mm) diameter clearance for fasteners (3 plcs). (Not to scale)

2.37" (60 mm)

3.25" (83 mm)

Head Top View. Fuel ports are 7/8"-14 SAE (SAEJ1926).

Item	Part No.	Description	Case Qty.
1	22351	Vent Plug Kit (2/kit) 3/4"-14 SAE	1
2	RK31547	Painted Head Assembly	1
3	S3207	Replacement Element for 3250R	6
	S3238	Replacement Element for 3150R	6
4	30965	Bowl Gasket	10
5	RK30063	Bowl w/Drain & 1/2"SAE Probe Port	1
	RK30900 ¹	Same as above with 12vdc Heater	1
	RK30925 ¹	Same as above with 24vdc Heater	1
6	RK20126	Water Probe Port Plug	1
	RK30964 ²	Water Probe & Connector (not shown)	1
7	RK30476	Drain Valve with Seals	1
	30942	Installation Instructions, 3250R	

3150R
13.63" (346 mm)

3250R
17.25" (438 mm)

¹ In-bowl heater may require a Heater Relay Kit.
² Must be used with Water Detection Kit.
 See Accessories Section.
 For parts not listed, call Racor customer service: (800) 344-3286.

Performance Graphs

These results are from controlled laboratory tests. Field results may vary by application.

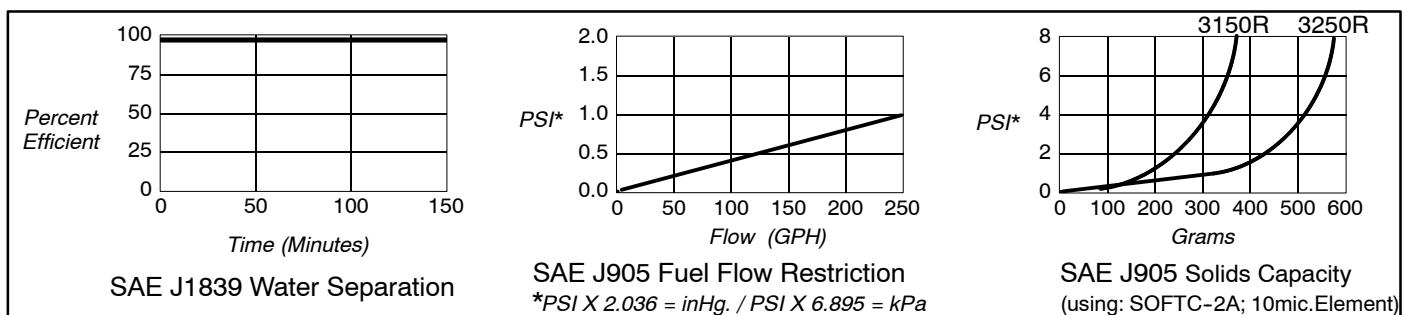

Selection Information

General

The Racor 300RC Diesel Spin-On Series feature a coolant heat exchanger attached to the mounting head to maintain applied heat to keep equipment operating in very cold temperatures or climates. The compact size allows the units to fit in tight engine compartments.

Mounting Heads:

These units all feature 3/8" NPTF fuel ports and have a unitized mounting bracket. The coolant heat exchanger is a separate part attached with a center cap. By loosening the cap, the heat exchanger ports may be rotated to various positions for installation convenience. All attach to 5/8" I.D. coolant hose.

Note: Because of the high heat exchange efficiency of this heater, a customer supplied shut-off valve(s) will be required for the installation.

Filters:

All units feature spin-on replaceable filters and contaminant collection bowls. All units may be specified with an in-bowl water probe when used with diesel or kerosene applications.

High-capacity Aquabloc™ filter elements, which stop water and remove solid contamination, are available in 2, 10 or 30 micron. Equipment owners can specify their filtration needs based on application, fuel quality, operating climates and maintenance schedules.

A 30 micron filter (or primary filter) is used to filter raw fuel (or poor quality fuel) before it can be further filtered by finer medias such as a 10 or 2 micron. A 10 micron filter (or secondary and even final) is used to filter fuel which is known to be of good quality. A 2 micron filter (or final filter) is the finest filtration available and is the last filter used prior to engine ingestion.

A simple rule to remember is the finer the filtration, the more frequent the filter change. *(Carry extra filters with your equipment).*

Reusable Collection Bowls:

The see-thru bowls used with these models won't discolor from alcohol, additives or UV light and have a leak-proof, positive seal drain for easy service. Water and contaminant levels can be seen easily at a glance. Metal bowls are not available.

Options -Available for Diesel fuel systems only.

Water Probe. All units may be ordered with an in-bowl water probe to alert the operator of a high-water condition, even while the equipment is operating. The bowl is then drained of water at the earliest convenience.

Note: A Racor Water Detection Module is needed to work with the probe. See Accessories.

Fuel Heater. These units may be ordered with an in-bowl 200 watt, thermostatically controlled resistance heater. This design places the heat source directly below the element to maximize heat transfer.

Note: An additional relay (or relay kit) may be needed to operate the fuel heater. See Accessories.

SELECTION

1. Along with the information you obtained in SECTION 1, SELECTION (page 2), consider the following: Are there any space limitations in the available location? The location should provide adequate space for removing the element and draining off contaminants from the bowl.
2. What filtration rating is needed? 2, 10 or 30 micron?
3. What options are needed? Water probe and/or an in-bowl heater?

Using this information, select a unit from the next page, or check the models which follow to find the right unit for your application.

For additional information, call your Racor dealer or call Racor customer service at (209) 521-7860 or (800) 344-3286, 6:00 AM to 5:00 PM, Pacific Time, or e-mail us from our website, www.parker.com/racor.

Model Illustrations

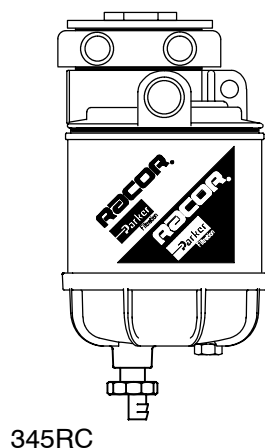

345RC



360RC

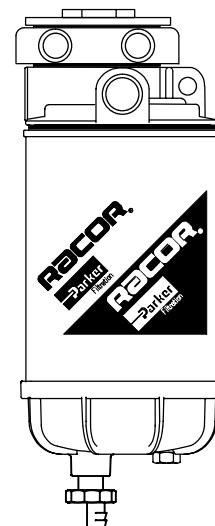

390RC

Special Notes

1. The 345RC, 360RC, and 390RC models feature a unitized mounting head that is standard with an efficient heat exchanger which may be rotated 360° for installation versatility. Engine coolant is used to heat the incoming fuel.
2. The heat exchanger operation is controlled manually, with customer supplied shut-off valves.
3. Allow at least 2 inches (51 mm) clearance under the units for replacement of element and water collection.
4. For additional information and availability, contact customer service at: (800) 344-3286, 6 AM to 5 PM, Pacific Time.

Specifications

BASIC MODELS		345RC	360RC	390RC
Maximum Flow Rate	GPH LPH	45 170	60 227	90 341
Fuel Port Size	NPTF	3/8"-18 (SAEJ476)	3/8"-18 (SAEJ476)	3/8"-18 (SAEJ476)
Coolant Barbs for Hose, Inside Diameter		5/8"	5/8"	5/8"
Service Filter Element Center Threads	SAE	R45 Series 1"-14	R60 Series 1"-14	R90 Series 1"-14
Height	in./mm	9.3 / 236	11 / 279	11.8 / 300
Width	in./mm	4.4 / 112	4.4 / 112	4.4 / 112
Depth	in./mm	4.8 / 122	4.8 / 122	4.8 / 122
Weight (dry)	Lbs./kgs.	2.5 / 1.1	2.7 / 1.3	2.9 / 1.4
Clean Element Pressure Drop	PSI/kPa	0.10 / 0.69	0.22 / 1.52	0.76 / 5.24
Max. Allowable Pressure	PSI/kPa	30 / 207	30 / 207	30 / 207
Bowl Water Capacity to probe tips (with heater)	ml ml	118 104	118 104	118 104
Operating Temperature		- 40° / +255° F / - 40° / +121° C		

Diesel Spin-On Series

Models 345RC, 360RC, 390RC

SPECIFICATIONS are found Diesel Spin-On Series introduction page.

How to Order -The example below illustrates how the part numbers are constructed.

345RC	P	12	2
345RC= 45 GPH 360RC= 60 GPH 390RC= 90 GPH	<u>Water Sensor Probe:</u> ¹ Add 'P' for an in-bowl water sensor. (Omit if not desired).	<u>200 watt In-bowl Electric Heater:</u> ² '12' for 12 vdc '24' for 24 vdc (Omit if not desired).	<u>Element Filtration Rating. Specify:</u> 2 for 2 micron 10 for 10 micron 30 for 30 micron
¹ Must be used with Water Detection Kit. See Accessories Section. ² Recommended for use with Racor Heater Relay Kit. See Accessories Section.			

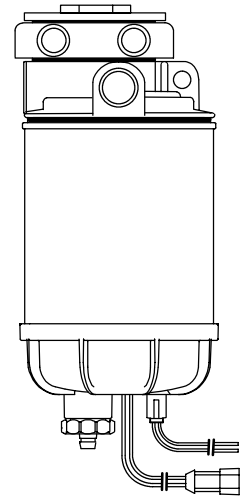

360RC shown

Replacement Service Elements -Service elements include filter seals.

Model	Final Filtration 2 Micron	Secondary Filtration 10 Micron	Primary Filtration* 30 Micron
345RC	R45S	R45T	R45P
360RC	R60S	R60T	R60P
390RC	R90S	R90T	R90P

*A secondary/final filter is required downstream.

Mounting Hole Pattern -Refer to section introduction page for filter dimensions.

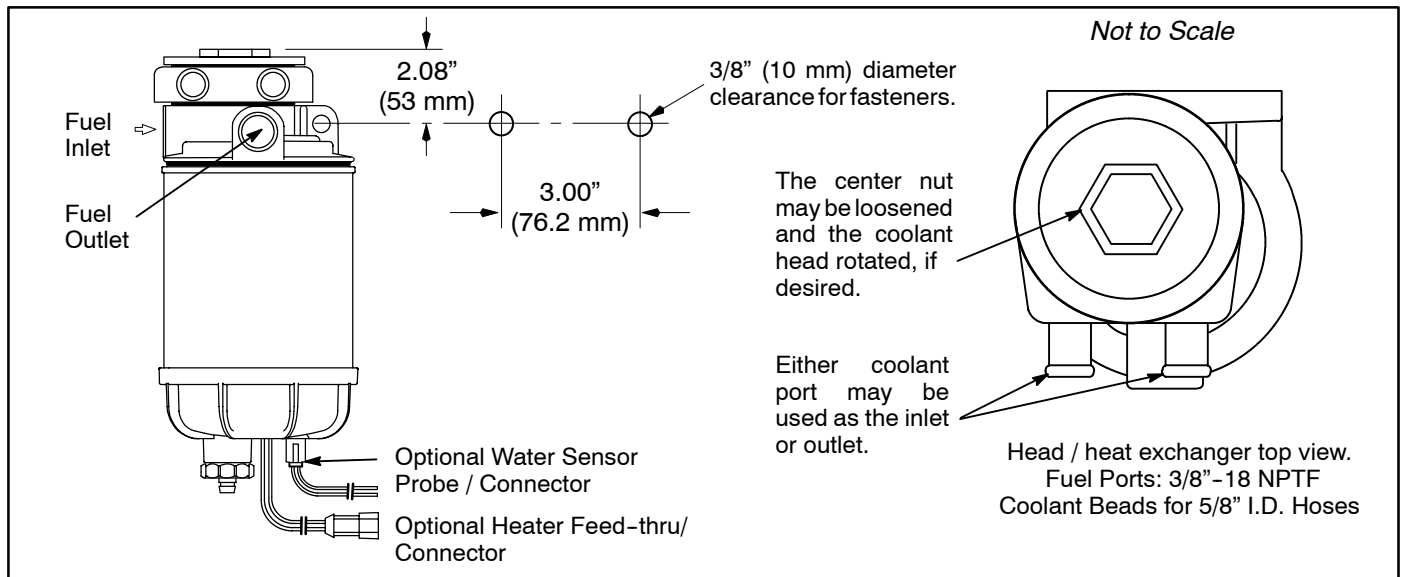

Performance Graphs -These results are from controlled laboratory tests. Field results may vary.

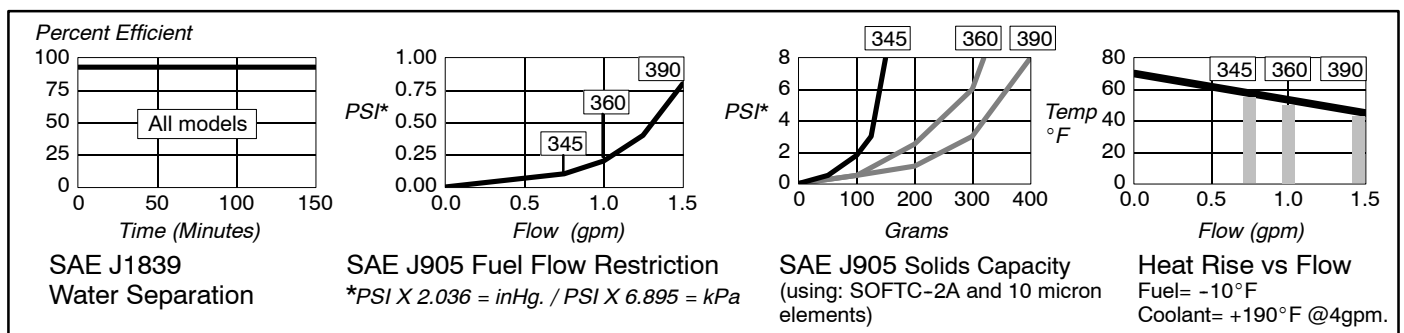
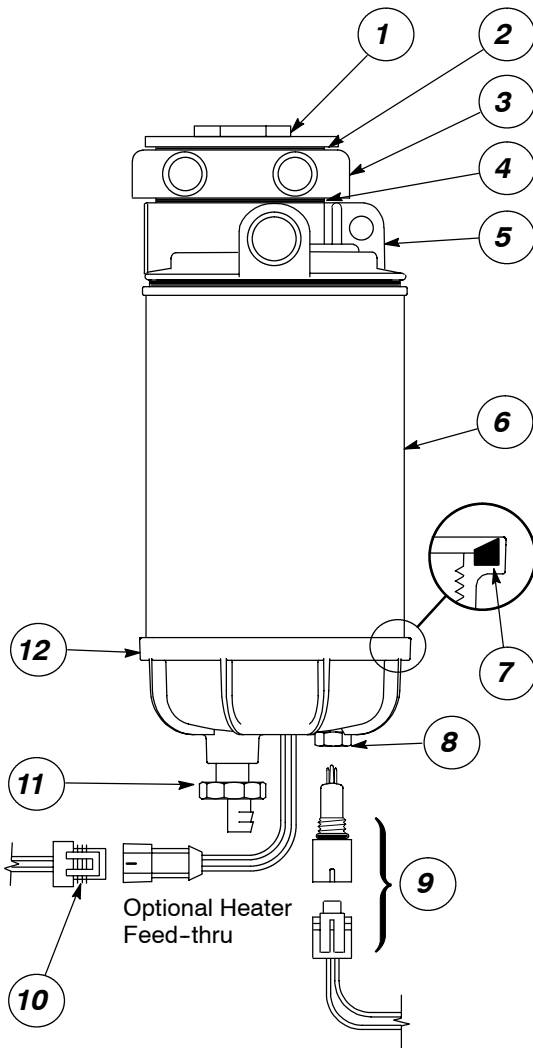

FIGURE 1. 300RC Series. The circled number corresponds to the item number shown in the parts list below.



Item/Part No.	Description	Case Qty.
1	RK30234 Heat Exchanger Cap	1
2	RK10012 Cap / Heat Exchanger O-ring	1
3	RK30235-02 Heat Exchanger	1
4	30237 Square-cut Gasket	1
5	RK22365-01 Filter Head w/ Element Adapter	1
6	R45S 345 Service Element, 2 micron	12
	R45T 345 Service Element, 10 micron	12
	R45P 345 Service Element, 30 micron	12
	R60S 360 Service Element, 2 micron	12
	R60T 360 Service Element, 10 micron	12
	R60P 360 Service Element, 30 micron	12
	R90S 390 Service Element, 2 micron	6
	R90T 390 Service Element, 10 micron	6
	R90P 390 Service Element, 30 micron	6
7	RK22333 Bowl Bevel Cut Gasket (#22333)	1
8	RK20126 Water Probe Port Plug (1/2" SAE)	1
9	RK30964 ¹ Water Probe (1/2" SAE) & Connector	1
10	RK22323 Heater Connector	1
11	RK30476 Bowl Self-venting Drain Valve Assembly	1
12	RK21113-13-11 Bowl w/Drain & Wtr.Probe Port Plug (1/2" SAE)	1
	RK22616-01 ² Bowl w/Drain,Wtr.Prb.Plug & 12vdc Heater	1
	RK22616-02 ² Bowl w/Drain,Wtr.Prb.Plug & 24vdc Heater	1
	RK22493 300 Series Complete Seal Kit	1
	22424 Installation Instructions, 300RC Series	

¹ Must be used with a Water Detection Kit.

² In-bowl heater may require a Heater Relay Kit.

See Accessories Section.

Bowl Type Used Prior to May, 1997

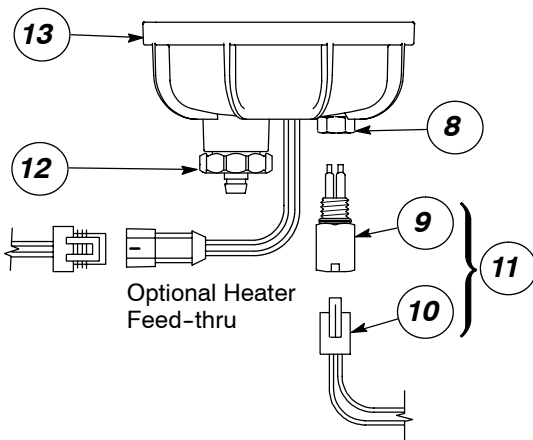

8	RK11-1679 Water Probe Port Plug (9/16"SAE)	1
9	RK21145 ¹ Water Probe Only (9/16"SAE)	1
10	RK21199 Water Probe Connector	1
11	RK22371 ¹ Water Probe (9/16"SAE) & Connector	1
12	RK22329 Bowl Drain Valve Assembly	1
13	RK21113 Bowl w/Drain & Wtr.Probe Port Plug (9/16"SAE)	1
	RK21113-13 Bowl w/Drain & Water Probe (9/16"SAE)	1
	RK22266-01 ² Bowl w/Drain,Wtr.Prb.Plug& 12 v Heater	1
	RK22266-02 ² Bowl w/Drain,Wtr.Prb.Plug& 24 v Heater	1
	RK22266-03 ² Bowl w/Drain,Water Probe & 12vdc Heater	1
	RK22266-04 ² Bowl w/Drain,Water Probe & 24vdc Heater	1

¹ Must be used with a Water Detection Kit.

² In-bowl heater may require a Heater Relay Kit.

See Accessories Section.

Selection Information

General

The Racor 400 Diesel Spin-On Series feature a unitized priming pump and multiple fuel ports for installation convenience. The 400 Series boasts extremely low flow resistance due to the unique pump by-pass feature.

Mounting Heads:

These units all feature two inlets and outlets threaded 3/8" NPTF (except the 4120R: 3/4"-16 SAE) and have a unitized mounting bracket. All units feature a hand (palm) operated fuel priming pump to simplify service procedures.

Filters:

All units feature spin-on replaceable filters and contaminant collection bowls. All units may be specified with an in-bowl water probe when used with diesel or kerosene applications.

High-capacity Aquabloc™ filter elements, which stop water and remove solid contamination, are available in 2, 10 or 30 micron. Equipment owners can specify their filtration needs based on application, fuel quality, operating climates and maintenance schedules.

A 30 micron filter (or primary filter) is used to filter raw fuel (or poor quality fuel) before it can be further filtered by finer medias such as a 10 or 2 micron. A 10 micron filter (or secondary and even final) is used to filter fuel which is known to be of good quality. A 2 micron filter (or final filter) is the finest filtration available and is the last filter used prior to engine ingestion.

A simple rule to remember is the finer the filtration, the more frequent the filter change. (*Carry extra filters with your equipment*).

Reusable Collection Bowls:

The see-thru bowls used with these models won't discolor from alcohol, additives or UV light and have a leak-proof, positive seal drain for easy service. Water and contaminant levels can be seen easily at a glance. Metal bowls are not available.

Options -Available for Diesel fuel systems only.

Water Probe. All units may be ordered with an in-bowl water probe to alert the operator of a high-water condition, even while the equipment is operating. The bowl is then drained of water at the earliest convenience. Note: A Racor Water Detection Module is needed to work with the probe. See Accessories. **Danger!** Do not use a water probe with gasoline applications. This may cause an explosion.

Fuel Heater. These units may be ordered with an in-bowl 200 watt, thermostatically controlled resistance heater. This design places the heat source directly below the element to maximize heat transfer.

The automatic thermostat will activate the heater at 45°F and deactivate the heater at 85°F.

Note: An additional relay kit may be needed to operate the fuel heater. See Accessories.

SELECTION

1. Along with the information you obtained in SECTION 1, SELECTION (page 2), consider the following: Are there any space limitations in the available location? The location should provide adequate space for removing the element, draining off contaminants from the bowl (and operating the primer pump on those applicable models).
2. What filtration rating is needed? 2, 10 or 30 micron?
3. What options are needed? Water probe and/or an in-bowl heater?

Using this information, select a unit from the next page, or check the models which follow to find the right unit for your application.

For additional information, call your Racor dealer or call Racor customer service at (209) 521-7860 or (800) 344-3286, 6:00 AM to 5:00 PM, Pacific Time, or e-mail us from our website, www.parker.com/racor.

Model Illustrations

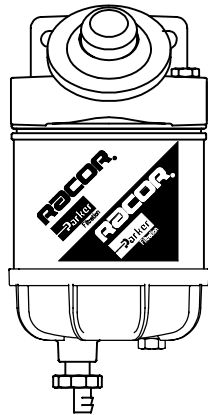

445R

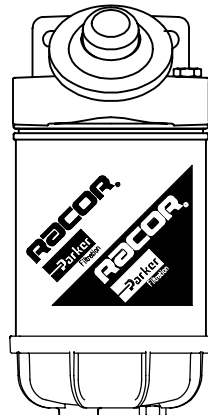

460R



490R



4120R

Special Notes

1. All models include the hand primer pump as standard.
2. Maximum power requirements for in-bowl heater options: 12vdc, 200 watt= 16.6 amps, 24vdc, 200 watt= 8.3 amps. Refer to Section 1 Accessories for available heater relay kits, if needed.
3. Allow at least 2 inches (51 mm) clearance under the units for replacement of element and water collection.
4. For additional information and availability, contact customer service at: (800) 344-3286, 6 AM to 5 PM, Pacific Time.

Specifications

BASIC MODELS		445R	460R	490R	4120R
Maximum Flow Rate	GPH / LPH	45 / 170	60 / 227	90 / 341	120 / 454
Fuel Port Size		3/8"-18 (4) NPTF	3/8"-18 (4) NPTF	3/8"-18 (4) NPTF	3/4"-16(4) SAE
Service Filter Element Center Threads	SAE	R45 Series 1"-14	R60 Series 1"-14	R90 Series 1"-14	R120 Series 1"-14
Height	in. / mm	9.3 / 236	11 / 279	11.8 / 300	15 / 381
Width	in. / mm	4.5 / 114	4.5 / 114	4.5 / 114	4.5 / 114
Depth	in. / mm	4.8 / 121	4.8 / 121	4.8 / 121	4.8 / 121
Weight (dry)	Lbs. / kgs.	2.5 / 1.1	2.7 / 1.3	2.9 / 1.4	3.9 / 1.8
Clean Element Pressure Drop	PSI / kPa	0.17 / 1.2	0.39 / 2.7	0.95 / 6.5	0.85 / 5.9
Max. Allowable Pressure	PSI / kPa	30 / 207	30 / 207	30 / 207	15 / 103
Bowl Water Capacity to probe tips (with heater)	ml	118 / 104	118 / 104	118 / 104	82 / 70
Operating Temperature		-40° / +255° F / -40° / +121° C			

Diesel Spin-On Series

Models 445R, 460R ,490R ,4120R

SPECIFICATIONS are found on 400 Diesel Spin-On Series introduction page.

How to Order -The example below illustrates how the part numbers are constructed.

Note: to order a unit with metric ports, specify an asterisk (*) in front of the part number.

445R	P	12	2
445R = 45 GPH 460R = 60 GPH 490R = 90 GPH 4120R=120 GPH	Water Probe: ¹ Add 'P' for an in-bowl water probe. (Omit if not desired).	200 watt In-bowl Electric Heater: ² '12' for 12 vdc '24' for 24 vdc (Omit if not desired).	Element Filtration Rating. Specify: 2 for 2 micron 10 for 10 micron 30 for 30 micron
¹ Must be used with Water Detection Kit. See Accessories Section. ² Recommended for use with Racor Heater Relay Kit. See Accessories Section.			



490R shown

Replacement Service Elements -Service elements include filter seals.

Model	Final Filtration 2 Micron	Secondary Filtration 10 Micron	Primary Filtration* 30 Micron
445R	R45S	R45T	R45P
460R	R60S	R60T	R60P
490R	R90S	R90T	R90P
4120R	R120S	R120T	R120P

*A secondary/final filter is required downstream.

Mounting Hole Pattern -Refer to section introduction page for filter dimensions.

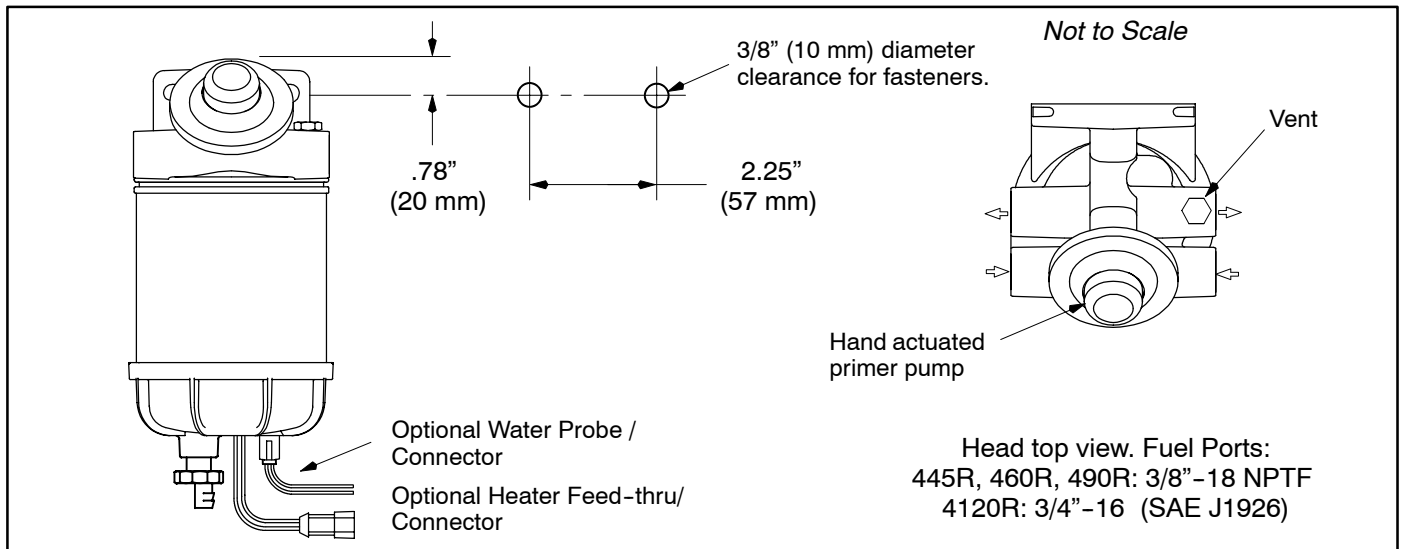

Performance Graphs -These results are from controlled laboratory tests. Field results may vary.

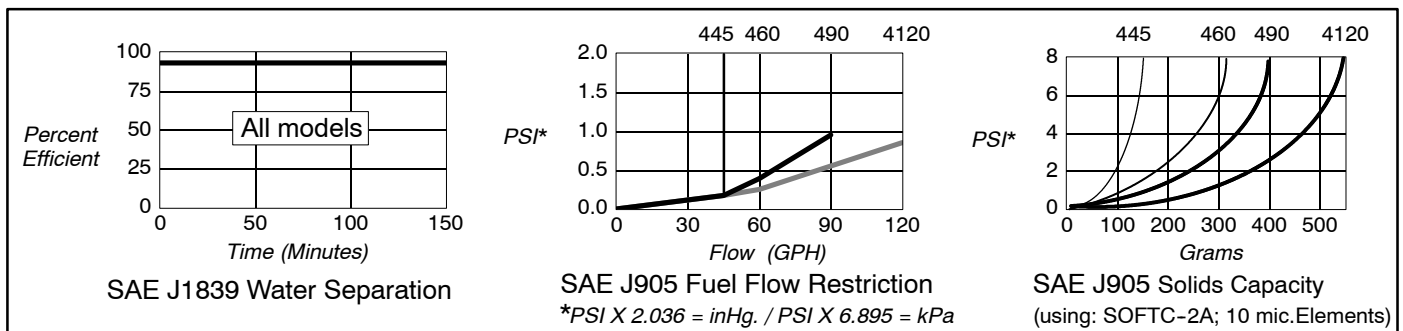
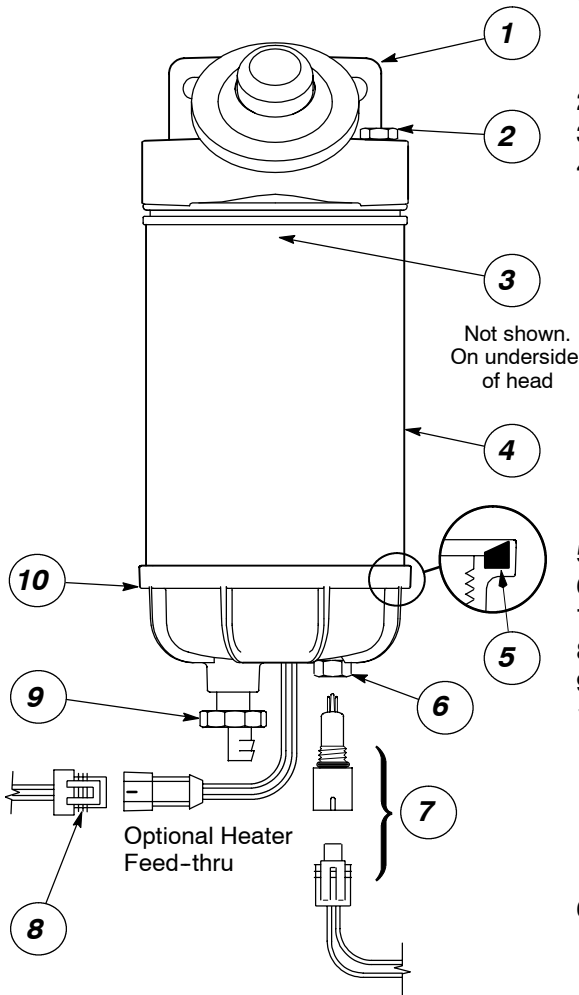

FIGURE 1. 400 Series. The circled number corresponds to the item number shown in the parts list below.



Item/Part No.	Description	Case Qty.	
1	RK22425	Beige Mounting Head, 3/8"-18 NPTF (400's)	1
	RK22168	Beige Mounting Head, 3/4"-16 SAE (4120)	1
	RK22168-05	Mounting Head, 16 mm X 1.5 metric ports	1
2	RK10110	Vent Plug (metal), 3/8"-24 SAE	1
3	RK22201	By-Pass Valve (not shown)	1
4	R45S	445 Service Element, 2 micron	12
	R45T	445 Service Element, 10 micron	12
	R45P	445 Service Element, 30 micron	12
	R60S	460 Service Element, 2 micron	12
	R60T	460 Service Element, 10 micron	12
	R60P	460 Service Element, 30 micron	12
	R90S	490 Service Element, 2 micron	6
	R90T	490 Service Element, 10 micron	6
	R90P	490 Service Element, 30 micron	6
	R120S	4120 Service Element, 2 micron	6
	R120T	4120 Service Element, 10 micron	6
	R120P	4120 Service Element, 30 micron	6
5	RK22333	Bowl Bevel-cut Gasket (#22333)	1
6	RK20126	Water Probe Port Plug (1/2"SAE)	1
7	RK30964 ¹	Water Probe (1/2" SAE) & Connector	1
8	RK22323	Heater Connector	1
9	RK30476	Bowl Self-venting Drain Valve Assembly	1
10	RK21113-13-11	Bowl w/Drain &Wtr.Probe Port Plug (1/2" SAE)	1
	RK22616-01 ²	Same as above but with 12vdc Heater & probe	1
	RK22616-02 ²	Same as above but with 24vdc Heater & probe	1
	22209	Installation Instructions, 400 Series	

BOWL COMPONENTS PRIOR TO MAY, 1997

6	RK11-1679	Water Probe Port Plug (9/16"SAE)	1
	RK21145 ¹	Water Probe Only (9/16"SAE)	1
	RK21199	Water Probe Connector	1
7	RK22371 ¹	Water Probe (9/16"SAE) & Connector	1
9	RK22329	Bowl Drain Valve Assembly (not shown)	1
10	RK21113-13	Bowl w/Drain valve and probe (9/16"SAE)	1

MODEL 4120R BOWL PARTS

11	30965	Bowl Gasket (formerly O-ring #30062)	10
12	RK20126	Water Probe Port Plug (1/2"SAE)	1
13	RK30964 ¹	Water Probe (1/2" SAE) & Connector	1
14	RK30876	Heater 2-pole Connector Kit	1
15	RK30476	Bowl Self-venting Drain Valve Assembly	1
	RK30058	Drain Valve with Seals (not shown)	1
16	RK30063	Bowl w/Drain & Probe Port Plug (1/2"SAE)	1
	RK30900 ²	Same as above but with 12vdc Heater	1
	RK30925 ²	Same as above but with 24vdc Heater	1

¹ Water probe must be used with a Water Detection Kit.
 Note: Check threads before ordering. Two different sizes were available on bowl designs prior to May, 1997.

² In-bowl heater may require a Heater Relay Kit. Power requirements (maximum) are: 12 vdc = 16.6 amps, 24 vdc = 8.3 amps.
 See Accessories Section.

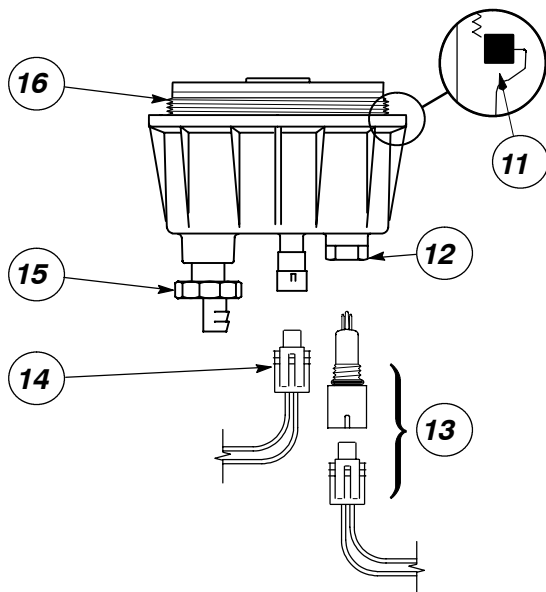

Selection Information

General

The 600 Series Diesel Fuel Filter/Water Separators feature multiple port mounting heads to fit a variety of installations.

Mounting Heads:

These units all feature seven tapered thread ports, four inlet and three outlet, for mounting versatility and have a unitized mounting bracket.

Filters:

All units feature spin-on replaceable filters and contaminant collection bowls. All units may be specified with an in-bowl water probe when used with diesel or kerosene applications.

High-capacity Aquabloc™ filter elements, which stop water and remove solid contamination, are available in 2, 10 or 30 micron. Equipment owners can specify their filtration needs based on application, fuel quality, operating climates and maintenance schedules.

A 30 micron filter (or primary filter) is used to filter raw fuel (or poor quality fuel) before it can be further filtered by finer medias such as a 10 or 2 micron. A 10 micron filter (or secondary and even final) is used to filter fuel which is known to be of good quality. A 2 micron filter (or final filter) is the finest filtration available and is the last filter used prior to engine ingestion.

A simple rule to remember is the finer the filtration, the more frequent the filter change. *(Carry extra filters with your equipment).*

Reusable Collection Bowls:

The see-thru bowls used with these models won't discolor from alcohol, additives or UV light and have a leak-proof, positive seal drain for easy service. Water and contaminant levels can be seen easily at a glance. Metal bowls are not available.

Options -Available for Diesel fuel systems only.

Water Probe. All units may be ordered with an in-bowl water probe to alert the operator of a high-water condition, even while the equipment is operating. The bowl is then drained of water at the earliest convenience. Note: A Racor Water Detection Module is needed to work with the probe. See Accessories.

Fuel Heater. These units may be ordered with an in-bowl 200 watt, thermostatically controlled resistance heater. This design places the heat source directly below the element to maximize heat transfer.

Note: An additional relay (or relay kit) may be needed to operate the fuel heater. See Accessories.

SELECTION

1. Along with the information you obtained in SECTION 1, SELECTION (page 2), consider the following: Are there any space limitations in the available location? The location should provide adequate space for removing the element and draining off contaminants from the bowl.
2. What filtration rating is needed? 2, 10 or 30 micron?
3. What options are needed? Water probe and/or an in-bowl heater?

Using this information, select a unit from the next page, or check the models which follow to find the right unit for your application.

For additional information, call your Racor dealer or call Racor customer service at (209) 521-7860 or (800) 344-3286, 6:00 AM to 5:00 PM, Pacific Time, or e-mail us from our website, www.parker.com/racor.

Model Illustrations

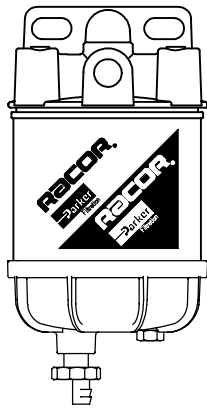

645R

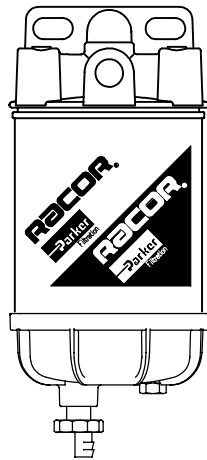

660R

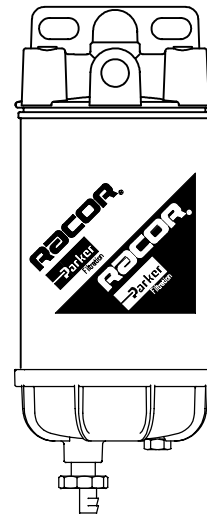

690R



6120R

Special Notes

1. Water probe and 200 watt In-bowl heater options are available.
2. Maximum power requirements for in-bowl heater options: 12vdc, 200 watt= 16.6 amps, 24vdc, 200 watt= 8.3 amps. Refer to Section 1 Accessories for available heater relay kits, if needed.
3. Allow at least 2 inches (51 mm) clearance under the units for replacement of element and water collection.
4. For additional information and availability, contact customer service at: 800/344-3286, PST.

Specifications

BASIC MODELS		645R	660R	690R	6120R
Maximum Flow Rate	GPH / LPH	45 / 170	60 / 227	90 / 341	120 / 454
Port Size, NPTF (SAEJ476)		3/8"-18 (7)	3/8"-18 (7)	3/8"-18 (7)	3/8"-18(7)
Service Filter Element Center Threads	SAE	R45 Series 1"-14	R60 Series 1"-14	R90 Series 1"-14	R120 Series 1"-14
Height	in. / mm	8.46 / 215	10.2 / 259	11.2 / 284	14.12 / 359
Width	in. / mm	4.5 / 114	4.5 / 114	4.5 / 114	4.5 / 114
Depth	in. / mm	4.5 / 114	4.5 / 114	4.5 / 114	4.5 / 114
Weight (dry)	Lbs. / kgs.	2.35 / 1.07	2.58 / 1.17	2.65 / 1.2	3.9 / 1.8
Clean Element Pressure Drop	PSI / kPa	0.01 / 0.07	0.05 / 0.34	0.29 / 2.0	2.65 / 18.27
Max. Allowable Pressure	PSI / kPa	30 / 207	30 / 207	30 / 207	15 / 103
Bowl Water Capacity to probe tips (with heater)	ml	118 / 104	118 / 104	118 / 104	82 / 70
Operating Temperature		-40° / +255° F / -40° / +121° C			

Diesel Spin-On Series

Models 645R, 660R, 690R, 6120R

SPECIFICATIONS are found on 600 Diesel Spin-On Series introduction page.

How to Order -The example below illustrates how the part numbers are constructed.

Note: to order a unit with metric ports, specify an asterisk (*) in front of the part number.

645R	P	12	2
645R = 45 GPH 660R = 60 GPH 690R = 90 GPH 6120R=120 GPH	Water Probe: ¹ Add 'P' for an in-bowl water probe. (Omit if not desired).	200 watt In-bowl Electric Heater: ² '12' for 12 vdc '24' for 24 vdc (Omit if not desired).	Element Filtration Rating. Specify: 2 for 2 micron 10 for 10 micron 30 for 30 micron
¹ Must be used with Water Detection Kit. See Accessories Section. ² Recommended for use with Racor Heater Relay Kit. See Accessories Section.			

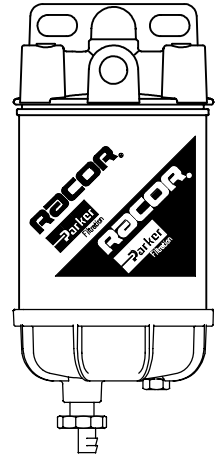

690R shown

Replacement Service Elements -Service elements include filter seals.

Model	Final Filtration 2 Micron	Secondary Filtration 10 Micron	Primary Filtration* 30 Micron
645R	R45S	R45T	R45P
660R	R60S	R60T	R60P
690R	R90S	R90T	R90P
6120R	R120S	R120T	R120P

*A secondary/final filter is required downstream.

Mounting Hole Pattern -Refer to section introduction page for filter dimensions.

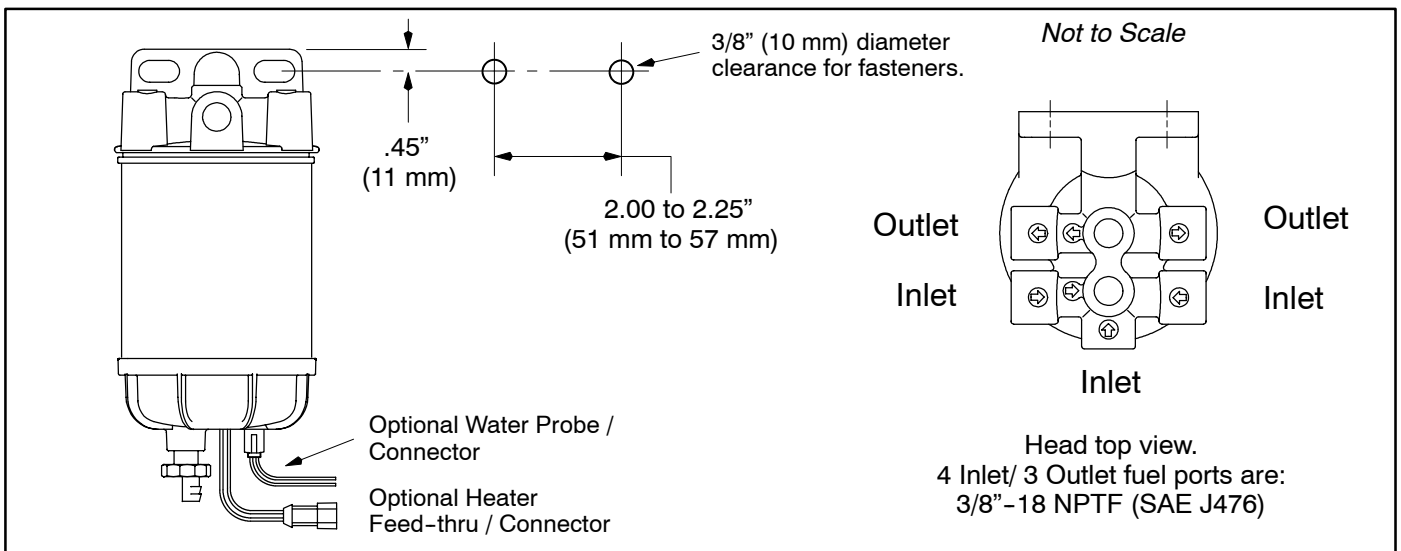

Performance Graphs -These results are from controlled laboratory tests. Field results may vary.

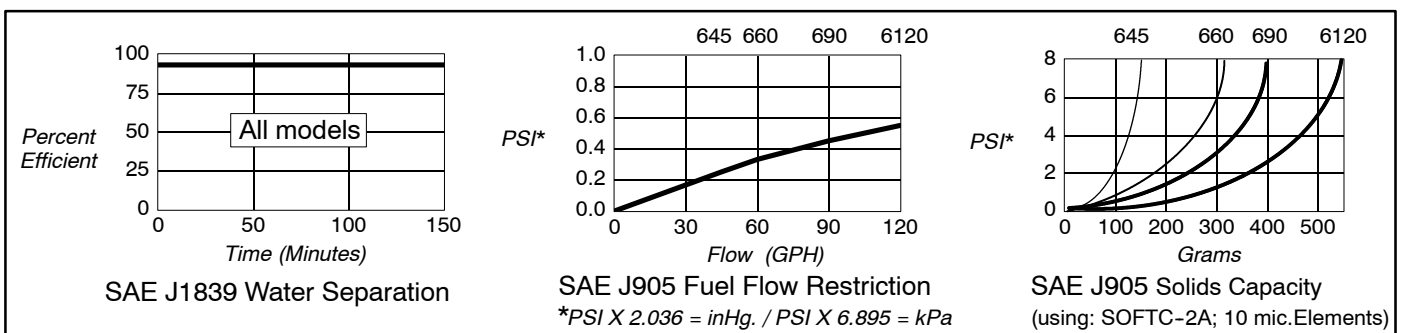

Diesel Spin-On Series

Models 645R, 660R, 690R, 6120R

1

FIGURE 1. 600 Series. The circled number corresponds to the item number shown in the parts list below.

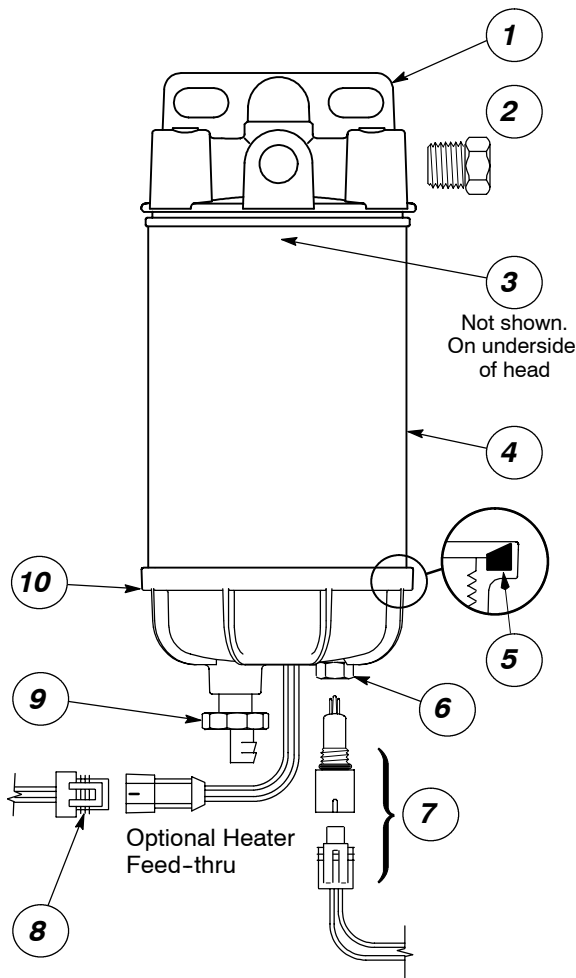

Item/Part No.	Description	Case Qty.
1	RK22098 Beige Mounting Head, 3/8"-18 NPTF	1
	RK22423 Mounting Head, 16 mm X 1.5 metric ports	1
2	01SP-6S Metal Plug, 3/8" NPTF	1
3	R45S 645 Service Element, 2 micron	12
	R45T 645 Service Element, 10 micron	12
	R45P 645 Service Element, 30 micron	12
	R60S 660 Service Element, 2 micron	12
	R60T 660 Service Element, 10 micron	12
	R60P 660 Service Element, 30 micron	12
	R90S 690 Service Element, 2 micron	6
	R90T 690 Service Element, 10 micron	6
	R90P 690 Service Element, 30 micron	6
	R120S 6120 Service Element, 2 micron	6
	R120T 6120 Service Element, 10 micron	6
	R120P 6120 Service Element, 30 micron	6
5	RK22333 Bowl Bevel-cut Gasket (#22333)	1
6	RK20126 Water Probe Port Plug (1/2"SAE)	1
7	RK30964 ¹ Water Probe (1/2" SAE) & Connector	1
8	RK22323 Heater Connector	1
9	RK30476 Bowl Self-venting Drain Valve Assembly	1
10	RK21113-13-11 Bowl w/Drain &Wtr.Probe Port Plug (1/2" SAE)	1
	RK22616-01 ² Same as above but with 12vdc Heater	1
	RK22616-02 ² Same as above but with 24vdc Heater	1
	22249 Installation Instructions, 645, 660 & 690	
	22506 Installation Instructions, 6120 only	

BOWL COMPONENTS PRIOR TO MAY, 1997

6	RK11-1679 Water Probe Port Plug (9/16"SAE)	1
	RK21145 ¹ Water Probe Only (9/16"SAE)	1
	RK21199 Water Probe Connector	1
7	RK22371 ¹ Water Probe (9/16"SAE) & Connector	1
9	RK22329 Bowl Drain Valve Assembly (not shown)	1
10	RK21113-13 Bowl w/Drain valve and probe (9/16"SAE)	1

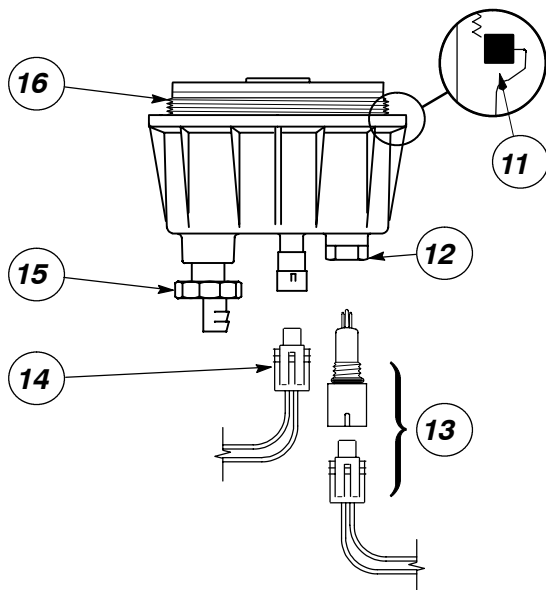

MODEL 6120R BOWL PARTS

11	30965 Bowl Gasket (formerly O-ring #30062)	10
12	RK20126 Water Probe Port Plug (1/2"SAE)	1
13	RK30964 ¹ Water Probe (1/2" SAE) & Connector	1
14	RK30876 Heater 2-pole Connector Kit	1
15	RK30476 Bowl Self-venting Drain Valve Assembly	1
	RK30058 Drain Valve with Seals (not shown)	1
16	RK30063 Bowl w/Drain & Probe Port Plug (1/2"SAE)	1
	RK30900 ² Same as above but with 12vdc Heater	1
	RK30925 ² Same as above but with 24vdc Heater	1

¹ Water probe must be used with a Water Detection Kit.

Note: Check threads before ordering. Two different sizes were available on bowl designs prior to May, 1997.

² In-bowl heater may require a Heater Relay Kit. Power requirements (maximum) are: 12 vdc = 16.6 amps, 24 vdc = 8.3 amps.

See Accessories Section.

Selection Information

General

Racor Turbine Series Fuel Filter/Water Separators have been protecting engines from water, dirt, foulants and other contaminants for over 30 years using a patented three-stage process:

- 1. Separation.** The turbine centrifuge separates solids and 'free' water through centrifugal action. Although the turbine has no moving parts, over 30% of the contaminants are removed here.
- 2. Coalescing.** Smaller water droplets and solids coalesce on the specially designed conical baffle and fall to the collection bowl.
- 3. Filtration.** Engines benefit from near 100% water separation and fuel filtration with Racor's proprietary Aquabloc™ water repelling media.

The units are designed for installation on the suction (vacuum) side of the fuel transfer pump for best efficiency but may be installed on the pressure side up to 15 PSI.

Filters:

High-capacity Aquabloc™ replaceable cartridge elements stop water and remove solid contamination and are available in 2, 10 or 30 micron. Equipment owners can specify their filtration needs based on application, fuel quality, operating climates and maintenance schedules.

A 30 micron filter (or primary filter) is used to filter raw fuel (or poor quality fuel) before it can be further filtered by finer medias such as a 10 or 2 micron.

A 10 micron filter (or secondary and even final) is used to filter fuel which is known to be of good quality.

A 2 micron filter (or final filter) is the finest filtration available and is the last filter used prior to engine ingestion.

A simple rule to remember is the finer the filtration, the more frequent the filter change. (*Carry extra filters with your equipment*).

Collection Bowls:

The see-thru bowls used with these models won't discolor from alcohol, additives or UV light and have a leak-proof, self-venting drain for easy service. Water and contaminant levels can be seen easily at a glance. For gasoline or severe service in diesel applications, specify metal bowls, only. (See Marine section for units with metal bowls).

Options -Available for Diesel fuel systems only.

Water Probe. All units may be ordered with an in-bowl water probe to alert the operator of a high-water condition, even while the equipment is operating. The bowl is then drained of water at the earliest convenience.

Note: A Racor Water Detection Module is needed to work with the probe. See Accessories.

Fuel Heater. These units may be ordered with an in-housing 300 watt (500 models: 150 watt), thermostatically controlled resistance heater. This design places the heat source below the element to maximize heat transfer.

Note: An additional relay (or relay kit) may be needed to operate the fuel heater. See Accessories.

SELECTION

1. Along with the information you obtained in SECTION 1, SELECTION (page 2), consider the following:

Are there any space limitations in the available location? The location should provide adequate overhead space for removing the element and underneath space for draining off contaminants from the bowl.

2. What filtration rating is needed? 2, 10 or 30 micron?

3. What options are needed? Water probe and/or an in-bowl heater?

4. Can the engine be shut down for servicing?

For engine(s) that cannot be shut-down if servicing becomes necessary, specify only FGV or FGX units.

Using this information, select a unit from the following page for your application.

For additional information, call your Racor dealer or call Racor customer service at (209) 521-7860 or (800) 344-3286, 6:00 AM to 5:00 PM, Pacific Time, or e-mail us from our website, www.parker.com/racor.

Model Illustrations

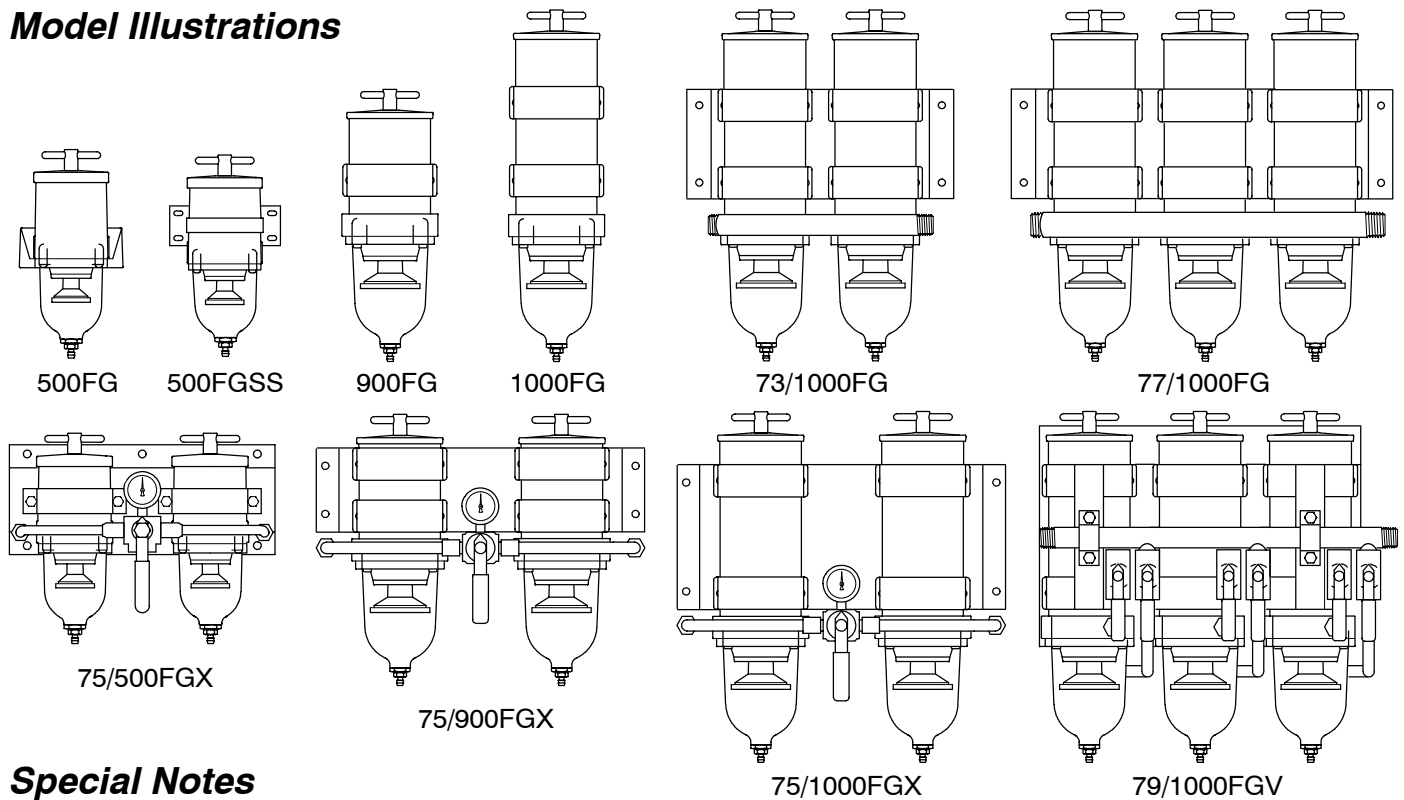

Special Notes

1. For units with metal bowls and heat shields, see Marine Turbine Series units for parts and information.
2. Allow at least 2 inches (51 mm) clearance under the units for draining water from the collection bowl.
3. For additional information and availability, contact customer service at: (800) 344-3286, 6 AM to 5 PM, Pacific Time.

Specifications

BASIC MODELS		500FG	900FG	1000FG	73/1000FG	75/500FGX	75/900FGX	75/1000FGX	77/1000FG	79/1000FGV
Maximum Flow Rate	GPH LPH	60 227	90 341	180 681	360 1363	120 454	180 681	360 1363	540 2044	540 2044
Port Size		3/4"-16 ^{1,2}	7/8"-14 ¹	7/8"-14 ¹	3/4"-14 ³	3/4"-16 ¹	7/8"-14 ⁴	7/8"-14 ⁴	1"-11 1/2 ³	3/4"-14 ³
Filter Element		2010 Series	2040 Series	2020 Series	2020 Series	2010 Series	2040 Series	2020 Series	2020 Series	2020 Series
Height	in./mm	11.5/292	17/432	22/559	22/559	11.5/292	17/432	22/559	22/559	22/559
Width	in./mm	5.8/147	6/152	6/152	16.5/419	14.5/368	18.8/476	18.8/476	21.5/546	21.5/546
Depth	in./mm	4.8/122	7/178	7/178	12/305	9.5/241	11/279	11/279	12/305	11.8/300
Weight	Lbs./kgs.	4/1.7	6/2.7	10/4.5	26/11.8	17/7.7	23/10.4	30/13.6	39/17.7	52/23.6
Clean Pressure Drop	PSI kPa	0.25 1.72	0.34 2.4	0.49 3.4	1.7 11.7	0.70 4.83	1.7 11.7	3.7 25.5	1.7 11.7	2.5 17.2
Max. Allowable Pressure	PSI .kPa	15 103	15 103	15 103	15 103	15 103	15 103	15 103	15 103	15 103
Bowl Water Capacity	ml	110	305	305	610	220	610	610	915	915
Overhead Clearance ⁵	in. mm	4 102	5 127	10 254	10 254	4 102	5 127	10 254	10 254	10 254
Operating Temperature		- 40° / +255° F / - 40° / +121° C								

¹ SAEJ1926 O-ring boss ² Effective 1/15/96, call factory for other sizes. ³ SAEJ476 (NPT) National Pipe Tapered thread
⁴ SAEJ514 (JIC) Joint Industry Council, 37° male flare ⁵ Required for element removal / servicing.

Turbine Series

Model 500FG

SPECIFICATIONS are found on *Turbine Series introduction page.*

How to Order -The example below illustrates how the part numbers are constructed.
 Note - to order a unit with metric threads, specify an asterisk (*) in front of the part number.

500FG	P	12	SS	10
Basic Model 60 GPH. For metal bowl unit see <i>Marine Turbine Series</i> in Section Two.	Water Probe. ¹ Add 'P' for an in-bowl water probe. (Omit if not desired).	150 watt Electric Heater: ² Add: '12' for 12 vdc or '24' for 24 vdc (Omit if not desired).	3-piece bracket: Add 'SS' for this bracket option. (Omit if not desired).	Element Filtration Rating. Specify one: '2' for 2 micron '10' for 10 micron or '30' for 30 micron
<p>¹ Must be used with Water Detection Kit -See Accessories Section. ² Recommended for use with Racor Heater Relay Kit -See Accessories Section.</p>				

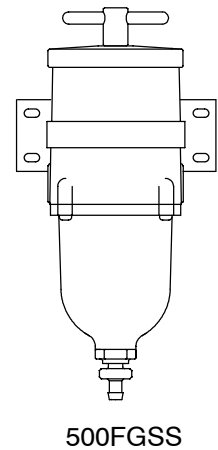
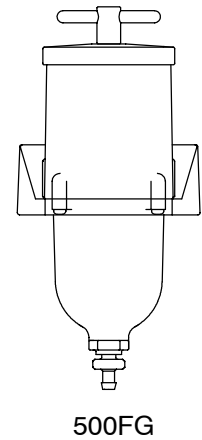

Replacement Service Elements -For all Model 500 Series
 SERVICE ELEMENT INCLUDES LID SEAL & T-HANDLE O-RING.

- 2010SM-OR** 2 Micron (Brown end caps)
Recommended for Final /Secondary Filtration
- 2010TM-OR** 10 Micron (Blue end caps)
Recommended for Primary or Secondary Filtration
- 2010PM-OR** 30 Micron (Red end caps)
Recommended for Primary Filtration Only.
(A secondary/final filter is required downstream).

Dimension / Mounting Hole Patterns

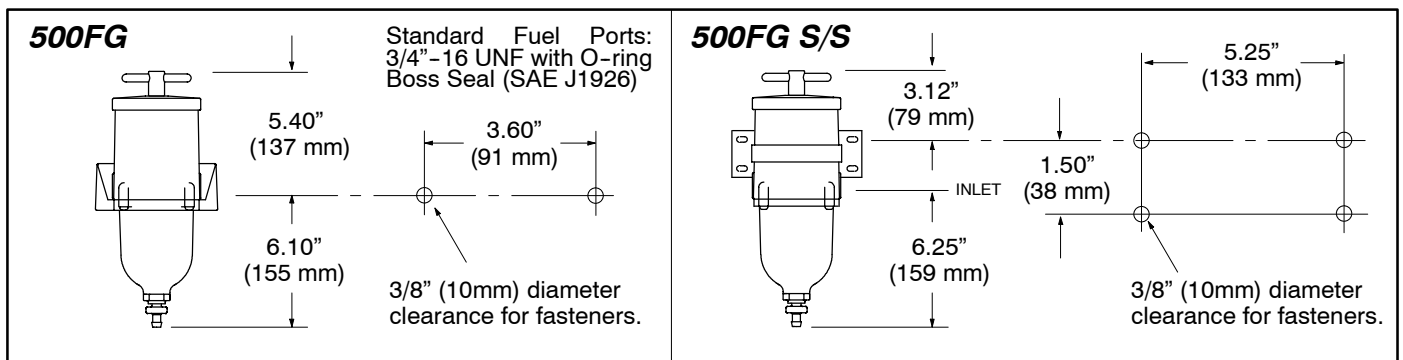

Performance Graphs These results are from controlled laboratory tests. Field results may vary.

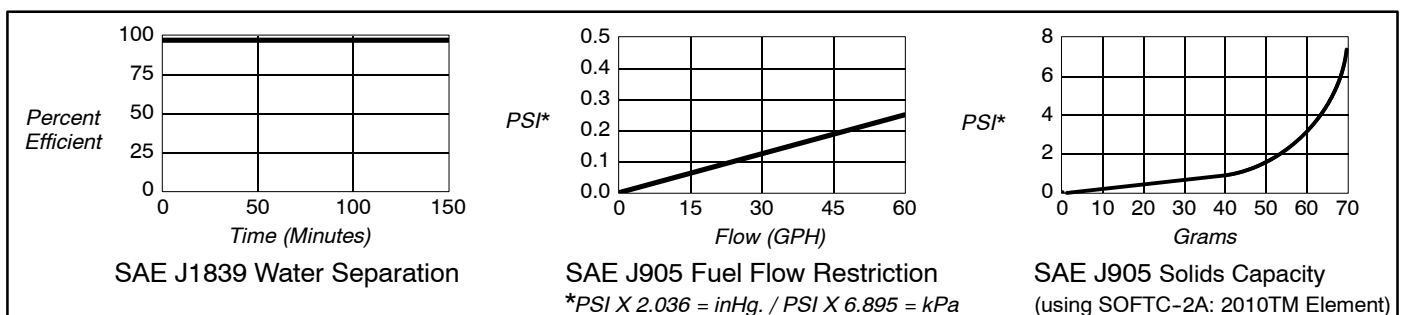
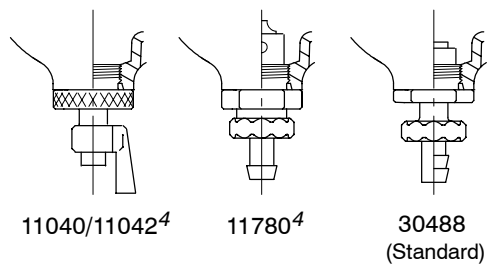
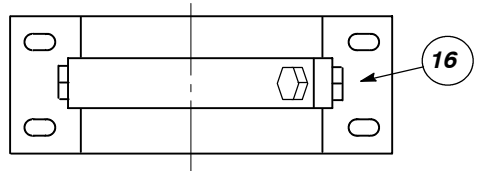
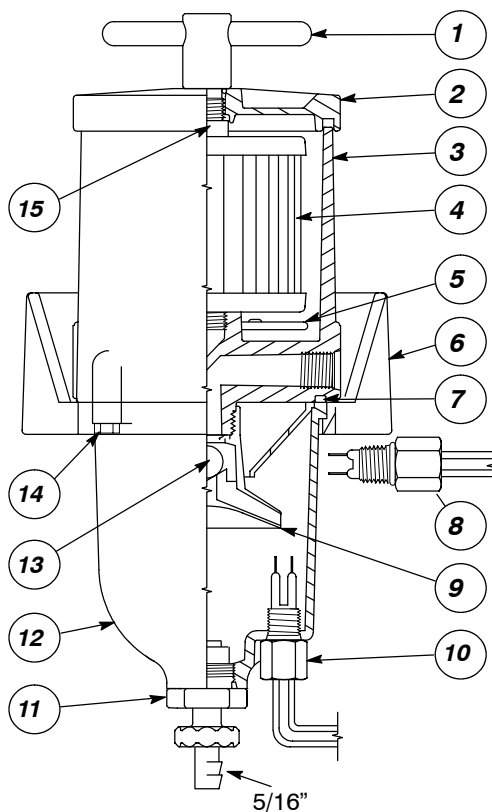

FIGURE 1. 500 Series Cutaway View. The circled number corresponds to the item number shown below.



Item/Part No.	Description	Case Qty.
1 RK11888	T-handle (FG/FGSS only), thread is 9/16"-18 SAE	1
11350	T-handle O-ring (FG)	10
11003	T-handle Nylon Gasket (FE/FF -not shown)	10
2 RK15078	Lid (FG/FGSS/FGMSS)	1
15005	Lid Gasket (All models)	10
3 RK15377-01	Body, 3/4"-16 UNF fuel ports (FG, effective 1/15/96)	1
RK15377-02	Body, 16M X 1.5 fuel ports (metric, effective 1/15/96)	1
RK15377-03	Body, 3/8"-18 NPTF fuel ports (effective 1/15/96)	1
RK15082	Body, 9/16"-18 UNF fuel ports (FF/FG)	1
4 2010SM-OR	2 Micron Element w/ Seals	12
2010TM-OR	10 Micron Element w/ Seals	12
2010PM-OR	30 Micron Element w/ Seals	12
5 RK15310-01	Heater, 12 vdc, 150 watt (for use with body feed-thru)	1
RK15383-01 ¹	Heater, 12 vdc, 150 watt with body feed-thru (item 8)	1
RK15310-02	Heater, 24 vdc, 150 watt (for use with body feed-thru)	1
RK15383-02 ¹	Heater, 24 vdc, 150 watt with body feed-thru (item 8)	1
HEATER RETROFIT KITS FOR OLDER UNITS: SEE ACCESSORIES		
6 RK15090	Mounting Bracket w/ Attached Bowl Ring (FG)	1
RK15035	Bowl Ring (FE/FF/FGSS -not shown)	1
7 15374	Bowl Gasket (supercedes 15009 O-ring -All models)	10
8 RK21067	Body Feed-thru Assembly (for bodies with feed-thru port) (wire gauge = 14 AWG)	1
9 RK15013D	Turbine Centrifuge / Conical Baffle (All models)	1
10 RK21069 ²	Water Probe (for bowls with 1/2"-20 UNF port present)	1
RK20126	Water Probe Port Plug (plastic)	1
11 RK30488	Self-Venting Drain (FF/FG/FGSS, See Figure 2)	10
11040	Bowl Drain Fitting (FE/FF, See Figure 2)	10
RK11341	Bowl Drain Gasket Kit (11041 & 11340 -not shown)	10
12 RK15279	See-thru Bowl w/ Water Probe Port & Plug	1
RK15301	Metal Bowl with 1/4"NPT drain threads (FFM/FGMSS)	1
13 RK15010B	Check Ball w/ Seal (All models)	1
14 RK15081-01 ³	Phillips Head Capscrews 10-24 x 1" (4)	1
RK15081 ³	Hex/Washer Head Capscrews 10-24 x 7/8" (4)	1
15 RK15079	Standard Return Tube	1
16 RK15300	Mounting Bracket, 3-piece Clamp Type (FGSS/FGM)	1
17 RK15211	Assembly Seal Service Kit, All models (not shown)	1
RK11746	Seal Service Kit for Drain #11780 (See Figure 2)	1
15332	Installation Instructions, 500 Series	

FIGURE 2. Drain valve configurations.
(⁴ Replace with 30488 drain valve)

¹ Filter body must have port next to fuel Inlet for heater feed-thru installation. In-filter heater kits may require a Heater Relay Kit. Power requirements are (maximum) : 12vdc = 12.5 amps, 24vdc = 6.3 amps.
² Water probe must be used with a Water Detection Kit.
³ Models built prior to 2/96 use RK15081-01, after 2/96 use RK15081.
 (The fuel ports have a 1 1/4" square boss on models made after 2/96).
 See Accessories Section.

Turbine Series

Model 900FG

SPECIFICATIONS are found on *Turbine Series introduction page*.

How to Order -The example below illustrates how the part numbers are constructed.
 Note - to order a unit with metric threads, specify an asterisk (*) in front of the part number.

900FG	P	312	10
<u>Basic Model</u> 90 GPH. For metal bowl unit see <i>Marine Turbine Series</i> in Section Two.	<u>Water Probe.</u> ¹ Add 'P' for an in-bowl water probe. (Omit if not desired).	<u>300 watt Electric Heater.</u> ² Specify: '312' for 12 vdc or '324' for 24 vdc (Omit if not desired).	<u>Element Filtration Rating.</u> Specify one: '2' for 2 micron '10' for 10 micron or '30' for 30 micron
¹ Must be used with Water Detection Kit -See Accessories Section. ² May require the use of a Relay Kit -See Accessories Section.			

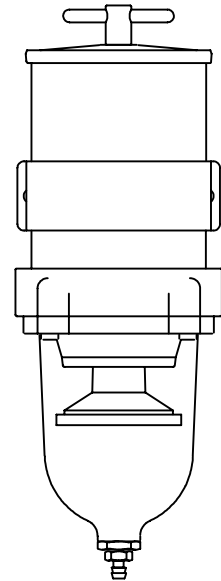

900FG

Replacement Service Elements -For all Model 900 Series
 SERVICE ELEMENT INCLUDES LID SEAL & T-HANDLE O-RING.

2040SM-OR	2 Micron (Brown end caps) Recommended for Final /Secondary Filtration
2040TM-OR	10 Micron (Blue end caps) Recommended for Primary or Secondary Filtration
2040PM-OR	30 Micron (Red end caps) Recommended for Primary Filtration Only. (A secondary/final filter is required downstream).

Mounting Hole Pattern -Refer to *Turbine Series introduction page* for filter dimensions.

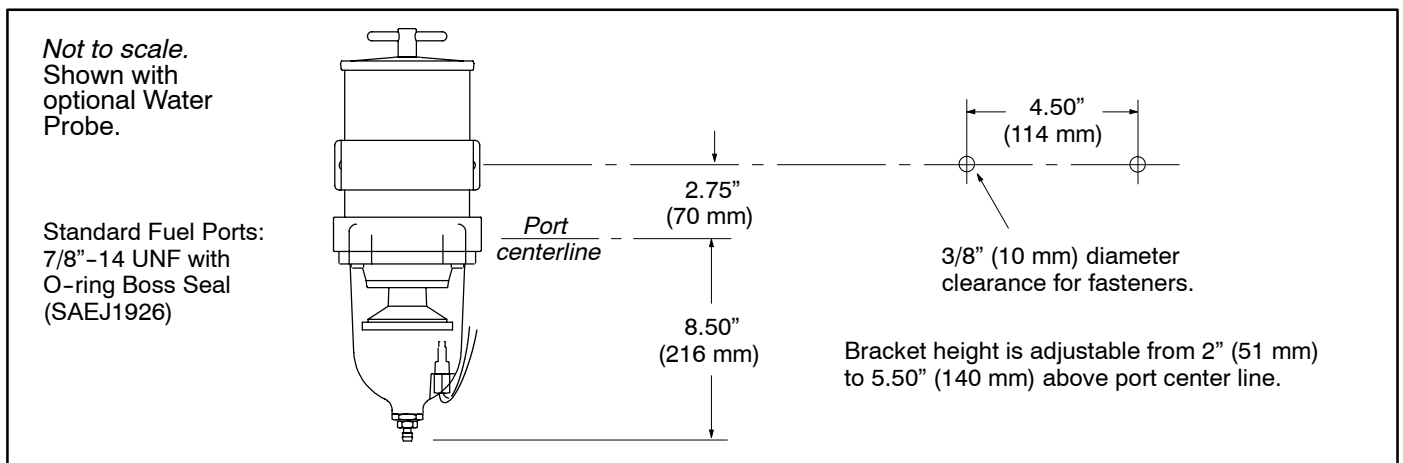

Performance Graphs -These results are from controlled laboratory tests. Field results may vary by application.

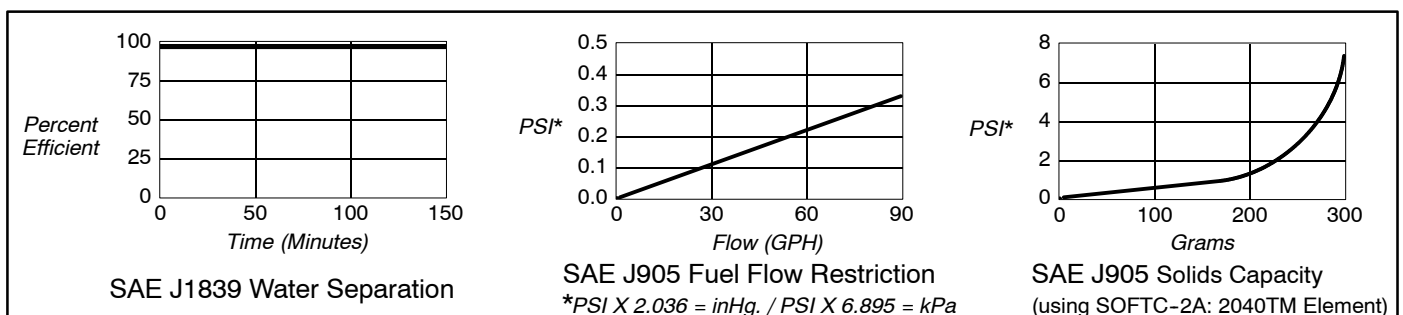
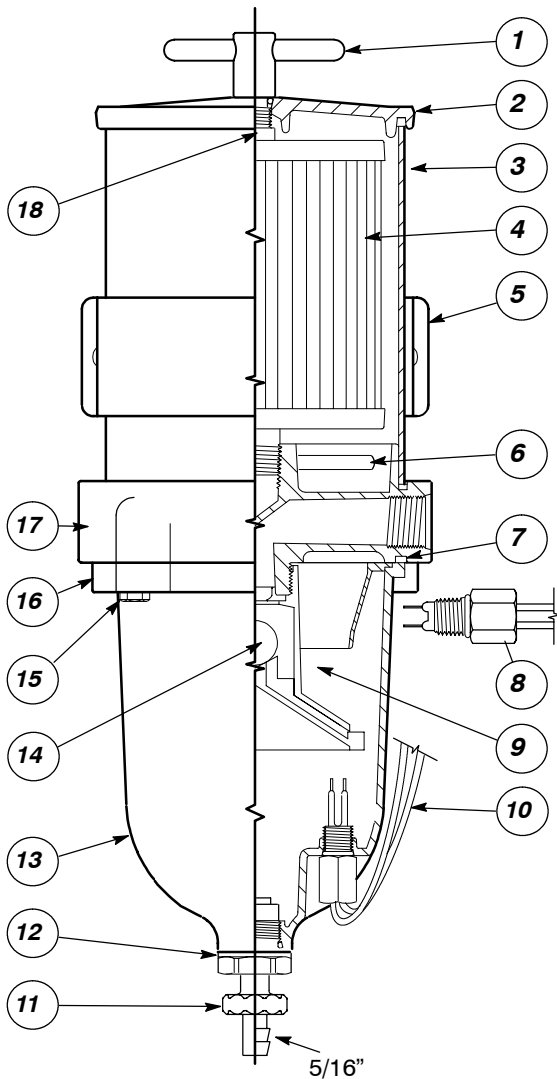

FIGURE 1. 900 Series Cutaway View. The circled number corresponds to the item number shown below.



Item/Part No.	Description	Case Qty.
1	RK11888 T-Handle, thread is 9/16"-18 SAE	1
	11350 T-Handle O-ring	10
	11003 T-Handle Gasket, Nylon (FE/FF)	10
2	RK11005B Standard Lid	1
	11007 Square-cut Gasket (Lid & Bowl ring)	10
	RK11005/A Lid, T-Handle and O-ring Kit	1
	RK11005B-02 Lid with Vent Port and Plug Kit (not shown)	1
3	RK19002 Outer Cylinder	1
4	2040SM-OR 2 Micron Element w/ Seals	12
	2040TM-OR 10 Micron Element w/ Seals	12
	2040PM-OR 30 Micron Element w/ Seals	12
5	RK11815-101 Body Clamp Bracket	1
6	RK11-1767-01 Heater, 12 vdc, 300 watt (for use with body feed-thru)	1
	RK11-1800-01 ¹ Heater, 12 vdc, 300 watt with body feed-thru (item 8)	1
	RK11-1767-02 Heater, 24 vdc, 300 watt (for use with body feed-thru)	1
	RK11-1800-02 ¹ Heater, 24 vdc, 300 watt with body feed-thru (item 8)	1
HEATER RETROFIT KITS FOR OLDER UNITS: SEE ACCESSORIES		
7	11007 Square-cut Gasket (Lid & Bowl ring)	10
	11036 Bowl O-Ring (FE only-not shown)	10
8	RK21067 Body Feed-thru Assy. (for bodies with feed-thru port) (wire gauge = 14 AWG)	1
	RK11-1679 Body Feed-thru Port Plug (plastic)	1
9	RK11026D Turbine Centrifuge / Conical Baffle	1
10	RK21069 ² Water Probe (for bowls with 1/2"-20 port)	1
	RK20126 Water Probe Port Plug (plastic)	1
11	RK30488 Self-venting Drain (FF/FG/FGSS, See Figure 2)	10
	RK11746 Seal Service Kit for Drain #11780 (See Figure 2)	1
12	11040 Bowl Drain Fitting (FE/FF, See Figure 2)	10
	RK11341 Bowl Drain Gasket Kit (11041 & 11340, not shown)	10
13	RK11-1606 See-thru Bowl with Water Probe Port & Plug	1
	RK11734 Metal Bowl w/1/4"NPT Drain & Plug (FGM)	1
	RK11734-01 Same as above but with Water Probe Port & Plug	1
14	RK11028B Check Ball and Seal	10
15	RK11542 Hex/Washer Head Capscrew, 1/4"-20 x 1" (4)	1
16	RK11037A Bowl Ring, 5" diameter (FF/FG)	1
17	RK11-1678 Body, 7/8"-14 SAE w/ Heater Feed-thru Port	1
	RK11-1776-01 Body, (Same as above but includes return tube)	1
	RK11-1776-02 Body, Metric 22mm X 1.5 with Heater Port	1
18	RK19474 Return Tube w/ straight (body-end) threads	1
	RK19001 Return Tube w/ tapered pipe (body-end) threads	1
19	RK11-1404 Assembly Seal Service Kit (all models-not shown)	1
	19472 Installation Instructions, 900/1000 Series	

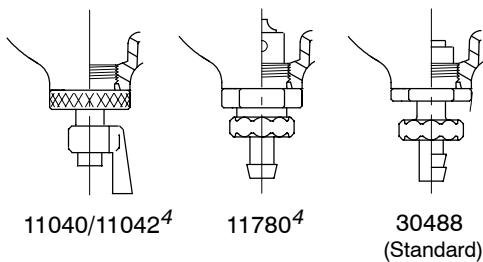

FIGURE 2. Drain valve configurations.
(⁴ Replace with 30488 drain valve)

¹ Filter body must have port next to fuel Inlet for heater feed-thru installation. In-filter heater may require a Heater Relay Kit. Power requirements are (maximum) : 12vdc = 25 amps, 24vdc = 12.5 amps.

² Water probe must be used with a Water Detection Kit. See Accessories Section.

Turbine Series

Model 1000FG

SPECIFICATIONS are found on Turbine Series introduction page.

How to Order -The example below illustrates how the part numbers are constructed.

Note - to order a unit with metric threads, specify an asterisk (*) in front of the part number.

1000FG	P	312	10
<u>Basic Model</u> 180 GPH. For metal bowl unit see <i>Marine Turbine Series</i> in Section Two.	<u>Water Probe.</u> ¹ Add 'P' for an in-bowl water probe. (Omit if not desired).	<u>300 watt Electric Heater.</u> ² Specify: '312' for 12 vdc or '324' for 24 vdc (Omit if not desired).	<u>Element Filtration Rating.</u> Specify one: '2' for 2 micron or '10' for 10 micron or '30' for 30 micron
¹ Must be used with Water Detection Kit -See Accessories Section. ² May require the use of a Relay Kit -See Accessories Section.			

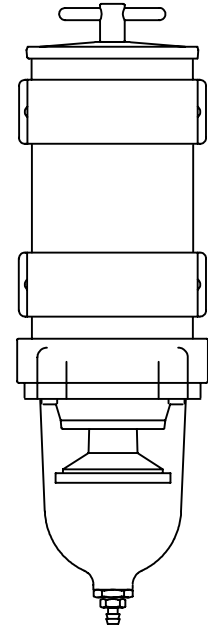

Replacement Service Elements -For all Model 1000 Series
 SERVICE ELEMENT INCLUDES LID SEAL & T-HANDLE O-RING.

2020SM-OR	2 Micron (Brown end caps) Recommended for Final /Secondary Filtration
2020TM-OR	10 Micron (Blue end caps) Recommended for Primary or Secondary Filtration
2020PM-OR	30 Micron (Red end caps) Recommended for Primary Filtration Only. (A secondary/final filter is required downstream)

Mounting Hole Pattern -Refer to Turbine Series introduction page for filter dimensions.

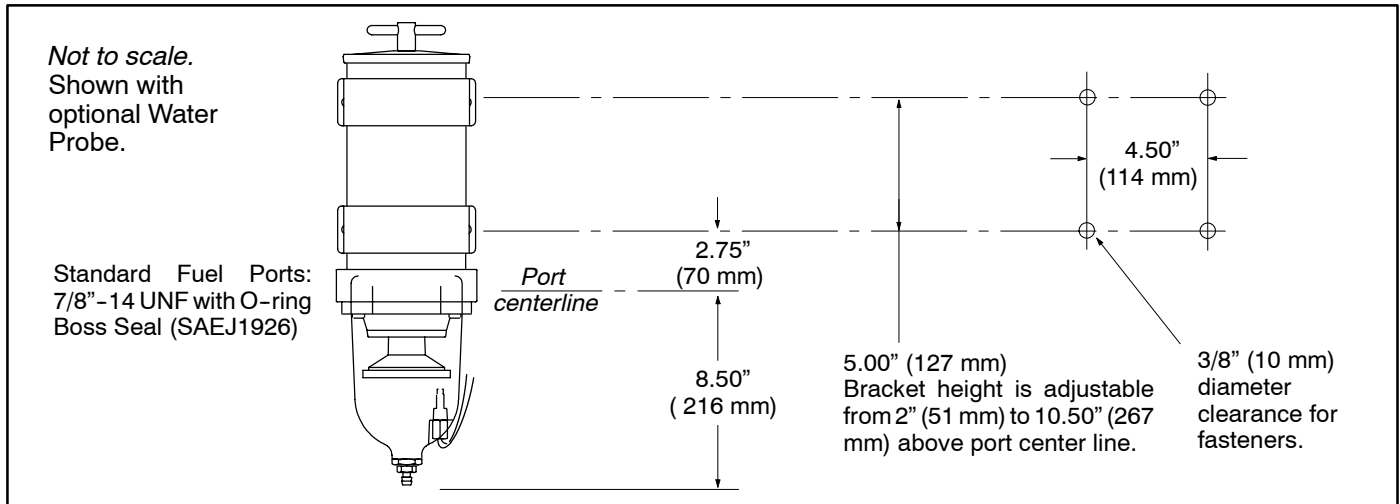

Performance Graphs -These results are from controlled laboratory tests. Field results may vary by application.

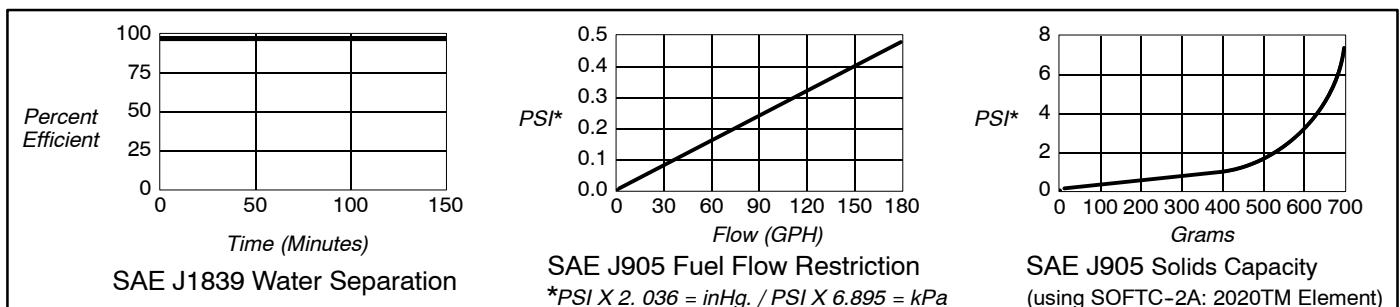
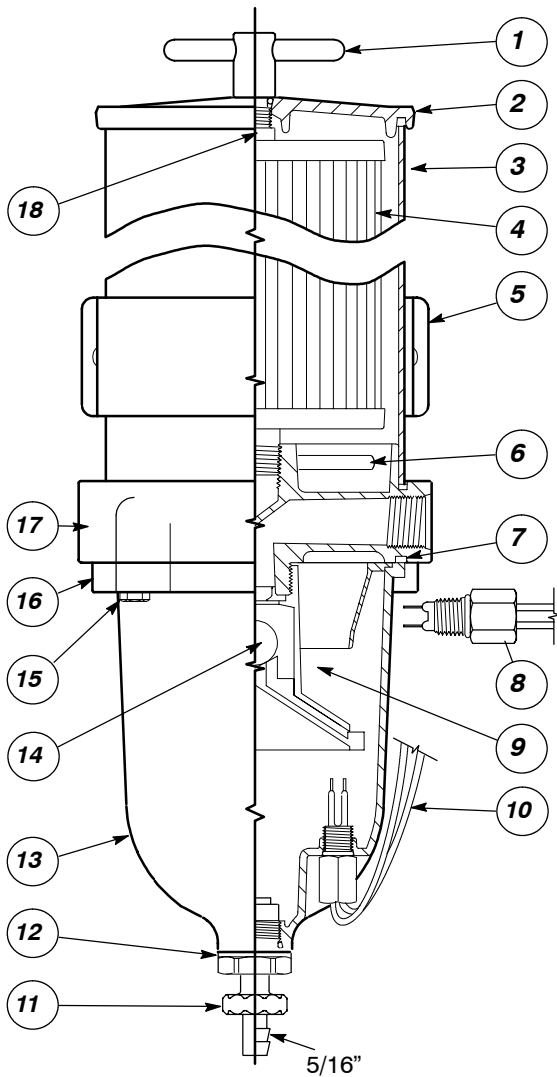

FIGURE 1. 1000 Series Cutaway View. The circled number corresponds to the item number shown below.



Item/Part No.	Description	Case Qty.
1	RK11888 T-Handle, thread is 9/16"-18 SAE	1
	11350 T-Handle O-ring	10
	11003 T-Handle Gasket, Nylon (FE/FF)	10
2	RK11005B Standard Lid	1
	11007 Square-cut Gasket (Lid & Bowl ring)	10
	RK11005/A Lid, T-Handle and O-ring Kit	1
	RK11005B-02 Lid with Vent Port and Plug Kit (not shown)	1
3	RK11021 Outer Cylinder	1
4	2020SM-OR 2 Micron Element w/ Seals	12
	2020TM-OR 10 Micron Element w/ Seals	12
	2020PM-OR 30 Micron Element w/ Seals	12
5	RK11815-101 Body Clamp Bracket	1
6	RK11-1767-01 Heater, 12 vdc, 300 watt (for use with body feed-thru)	1
	RK11-1800-01 ¹ Heater, 12 vdc, 300 watt with body feed-thru (item 8)	1
	RK11-1767-02 Heater, 24 vdc, 300 watt (for use with body feed-thru)	1
	RK11-1800-02 ¹ Heater, 24 vdc, 300 watt with body feed-thru (item 8)	1
HEATER RETROFIT KITS FOR OLDER UNITS: SEE ACCESSORIES		
7	11007 Square-cut Gasket (Lid & Bowl ring)	10
	11036 Bowl O-Ring (FE only-not shown)	10
8	RK21067 Body Feed-thru Assy. (for bodies with feed-thru port) (wire gauge = 14 AWG)	1
	RK11-1679 Body Feed-thru Port Plug (plastic)	1
9	RK11026D Turbine Centrifuge / Conical Baffle	1
10	RK21069 ² Water Probe (for bowls with 1/2"-20 port)	1
	RK20126 Water Probe Port Plug (plastic)	1
11	RK30488 Self-venting Drain (FF/FG/FGSS, See Figure 2)	10
	RK11746 Seal Service Kit for Drain #11780 (See Figure 2)	1
12	11040 Bowl Drain Fitting (FE/FF, See Figure 2)	10
	RK11341 Bowl Drain Gasket Kit (11041 & 11340, not shown)	10
13	RK11-1606 See-thru Bowl with Water Probe Port & Plug	1
	RK11734 Metal Bowl w/1/4"NPT Drain & Plug (FGM)	1
	RK11734-01 Same as above but with Water Probe Port & Plug	1
14	RK11028B Check Ball and Seal	10
15	RK11542 Hex/Washer Head Capscrew, 1/4"-20 x 1" (4)	1
16	RK11037A Bowl Ring, 5" diameter (FF/FG)	1
17	RK11-1678 Body, 7/8"-14 SAE w/ Heater Feed-thru Port	1
18	RK11-1775 Return Tube w/ straight (body-end) threads	1
	RK11008 Return Tube w/ tapered pipe (body-end) threads	1
19	RK11-1404 Assembly Seal Service Kit (all models-not shown)	1
	19472 Installation Instructions, 900/1000 Series	

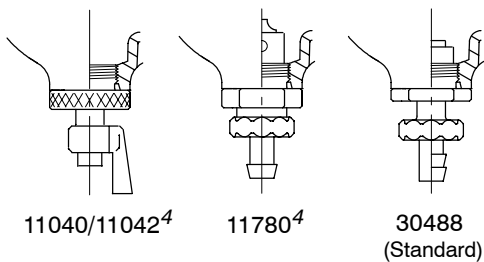

FIGURE 2. Drain valve configurations.
(⁴ Replace with 30488 drain valve)

¹ Filter body must have port next to fuel Inlet for heater feed-thru installation. In-filter heater may require a Heater Relay Kit. Power requirements are (maximum) : 12vdc = 25 amps, 24vdc = 12.5 amps.

² Water probe must be used with a Water Detection Kit. See Accessories Section.

Turbine Series

Model 73/1000FG

SPECIFICATIONS are found on Turbine Series introduction page.

How to Order -The example below illustrates how the part numbers are constructed.

73/1000FG	P	312	10
<u>Basic Model</u> 360 GPH For metal bowl unit see <i>Marine Turbine Series</i> in Section Two.	<u>Water Probes.</u> ¹ Add 'P' for in-bowl water probes. (Omit if not desired).	<u>300 watt Electric Heaters.</u> ² Specify: '312' for 12 vdc or '324' for 24 vdc. (Omit if not desired).	<u>Element Filtration Rating.</u> Specify one: '2' for 2 micron, '10' for 10 micron or '30' for 30 micron
¹ Must be used with Water Detection Kit -See Accessories Section. ² Must be used with a Relay Kit -See Accessories Section.			

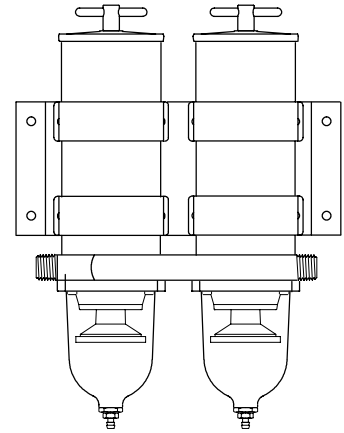

73/1000FG

Replacement Service Elements -For all Model 73/1000 Series

SERVICE ELEMENT INCLUDES LID SEAL & T-HANDLE O-RING. Order two (2) per unit.

2020SM-OR	2 Micron (Brown end caps) Recommended for Final /Secondary Filtration
2020TM-OR	10 Micron (Blue end caps) Recommended for Primary or Secondary Filtration
2020PM-OR	30 Micron (Red end caps) Recommended for Primary Filtration* Only. *A secondary/final filter is required downstream.

Mounting Hole Pattern -Refer to Turbine Series introduction page for filter dimensions.

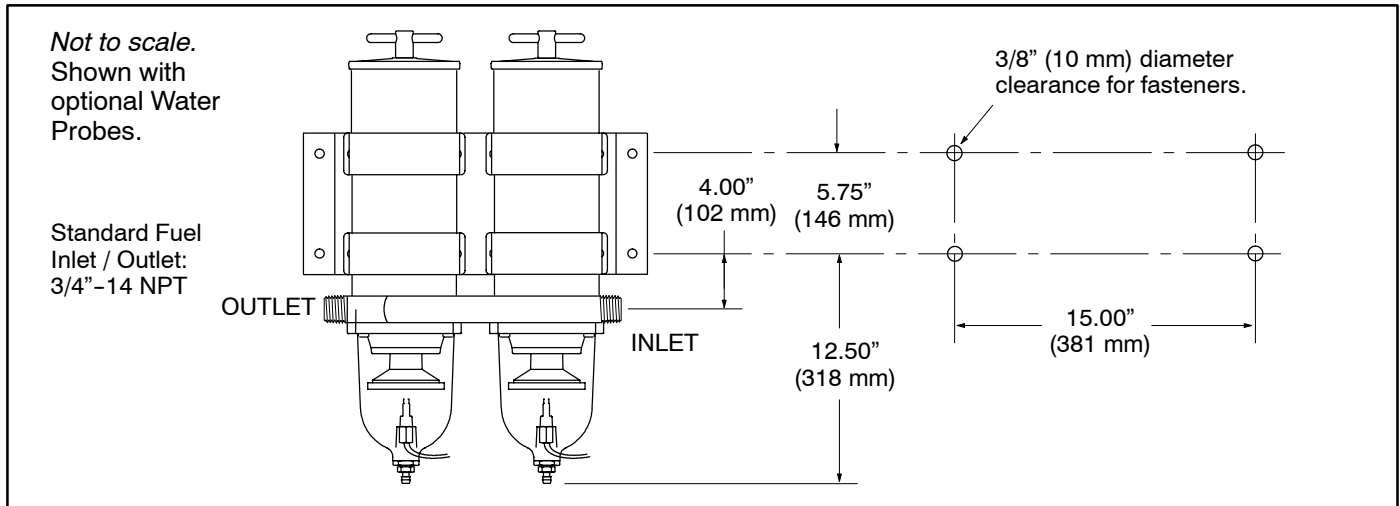

Performance Graphs - These results are from controlled laboratory tests. Field results may vary by application.

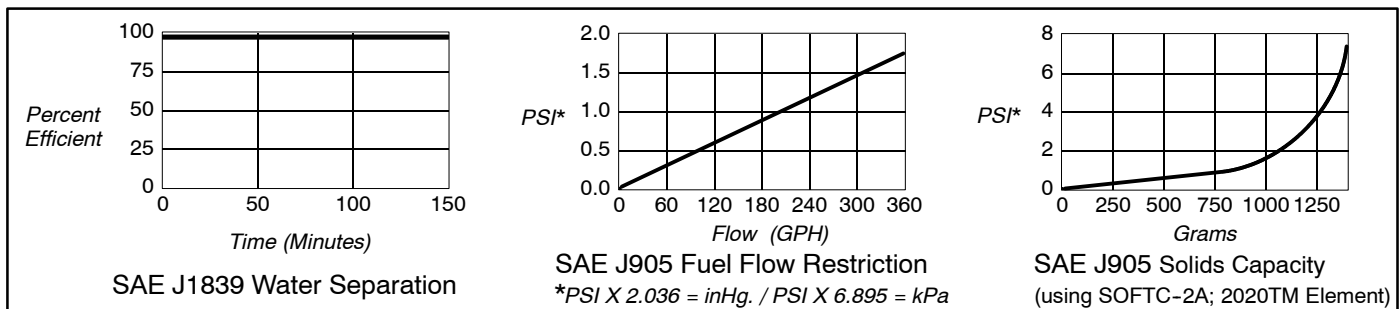
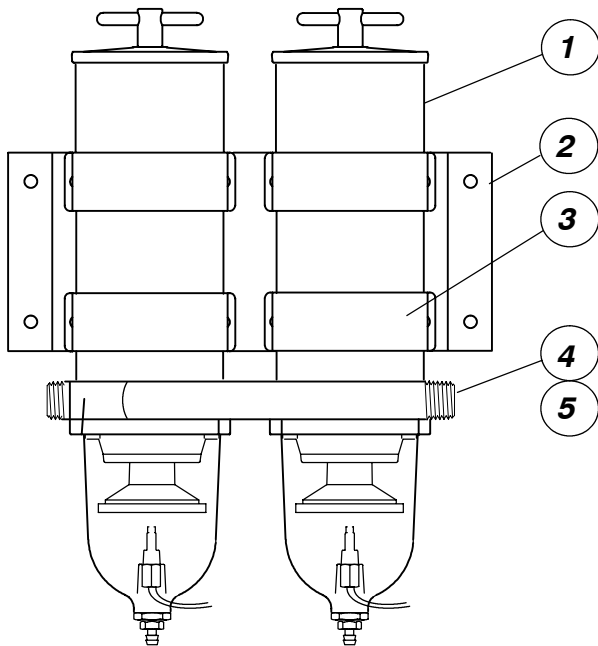

FIGURE 1. 73/1000 Series. The circled number corresponds to the item number shown in the parts list below.



Item	Part No.	Description	Case Qty.
1	1000FG	Shell. Refer to Model 1000FG for a complete parts list.	
2	11065	Dual Bracket	1
3	RK11815-101	Clamp Bracket Assembly	1
4	RK11892	3/4" Inlet & Outlet Manifolds	1
5	11071	Straight Fitting	1
	11-1825	Installation Instructions, 73/1000FG	

For Heater Relay Kits, Water Detection Kits and Manifold Conversion Kits, see the Accessories Section.

For parts not listed, call Racor customer service: (800) 344-3286.

73/1000FGP Model shown

Turbine Series

Model 75/500FGX

SPECIFICATIONS are found on *Turbine Series introduction page*.

How to Order -The example below illustrates how the part numbers are constructed.

75/500FGX	P	12	10
<u>Basic Model</u> 120 GPH For metal bowl unit see <i>Marine Turbine Series</i> in Section Two.	<u>Water Probes.</u> ¹ Add 'P' for in-bowl water probes. (Omit if not desired).	<u>150 watt Electric Heaters.</u> ² Specify: '12' for 12 vdc or '24' for 24 vdc. (Omit if not desired).	<u>Element Filtration Rating.</u> Specify one: 2 for 2 micron, 10 for 10 micron or 30 for 30 micron
¹ Must be used with Water Detection Kit -See Accessories Section. ² Must be used with a Relay Kit -See Accessories Section.			

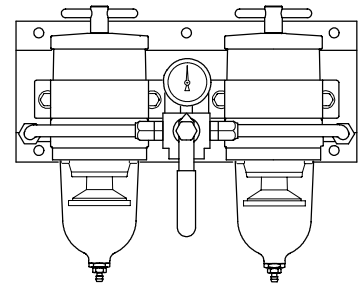

75/500FGX

Replacement Service Elements -For all Model 75/500FGX Series
 SERVICE ELEMENT INCLUDES LID SEAL & T-HANDLE O-RING. Order two (2) per unit.

2010SM-OR	2 Micron (Brown end caps) Recommended for Final /Secondary Filtration
2010TM-OR	10 Micron (Blue end caps) Recommended for Primary or Secondary Filtration
2010PM-OR	30 Micron (Red end caps) Recommended for Primary Filtration* Only. *A secondary/final filter is required downstream.

Mounting Hole Pattern -Refer to *Turbine Series introduction page* for filter dimensions.

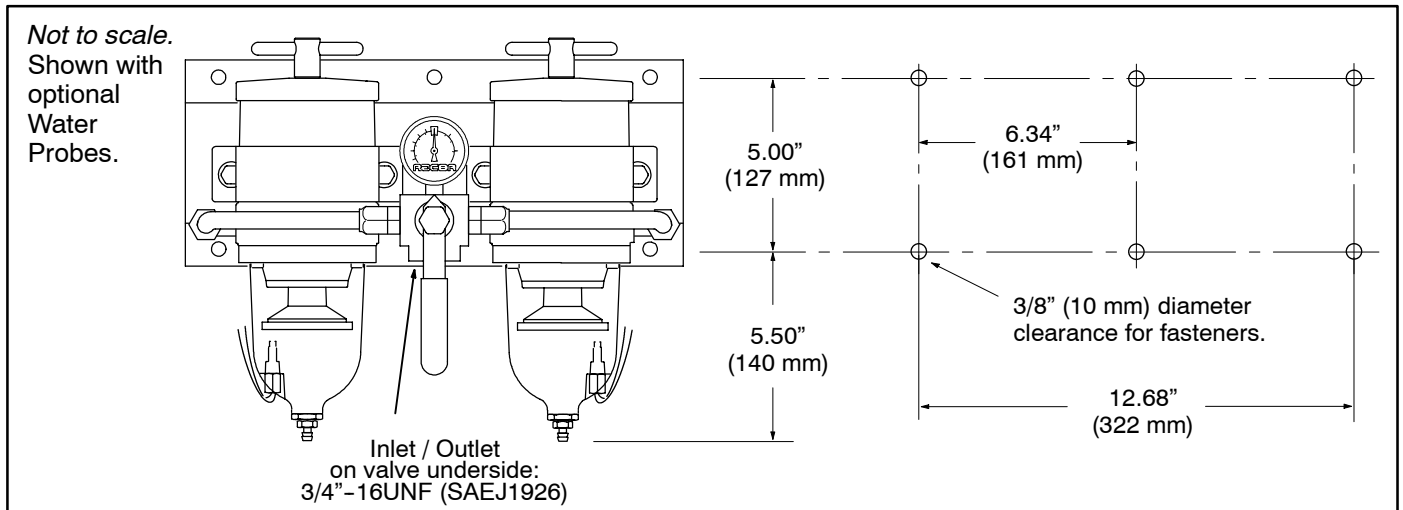

Performance Graphs -These results are from controlled laboratory tests. Field results may vary by application.

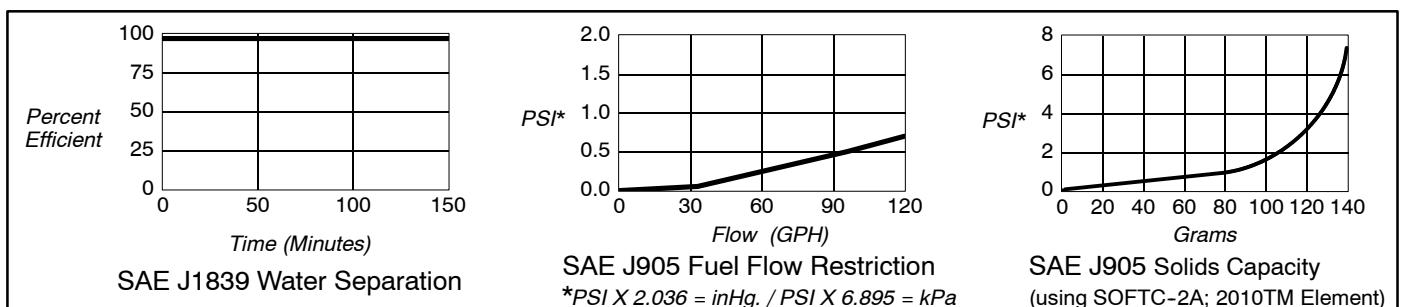
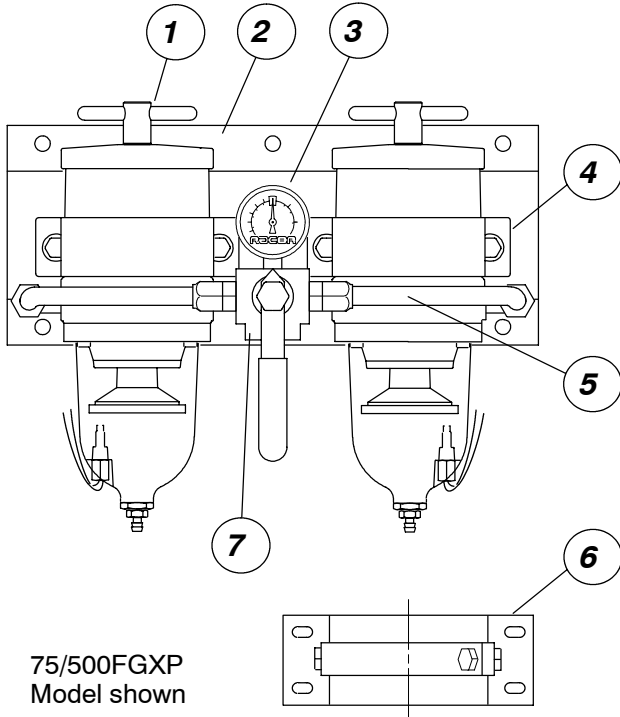

FIGURE 1. 75/500 Series. The circled number corresponds to the item number shown in the parts list below.



RK15300 Three-piece bracket

Item	Part No.	Description	Case Qty.
1	500FGSS	Shell. Refer to Model 500FGSS for a complete parts list	
2	RK15329	Main Bracket, (Shown, for one-pc.brkts)	1
	RK15329-01	Main Bracket, (Accommodates three piece body clamp brackets, see item 6)	1
3	RK19476	Gauge Assembly	1
4	RK15378	Body Clamp Bracket, One-Piece	1
5	RK15344	Rigid Tubing & Fittings Kit	1
6	RK15300	Body Clamp Bracket, Three-Piece	1
7	RK15321	Valve Assembly	1
	RK15389	Valve Service Kit	1
	15349	Installation Instructions	

For Fuel Port Adapter Fittings, Heater Relay Kits, Water Detection Kits and Manifold Conversion Kits, see the Accessories Section.

For parts not listed, call Racor customer service: 800/344-3286.

SPECIFICATIONS are found on Turbine Series introduction page.

How to Order -The example below illustrates how the part numbers are constructed.

75/900FGX	P	312	10
<u>Basic Model</u> 180 GPH For metal bowl unit see <i>Marine Turbine Series</i> in Section Two.	<u>Water Probes.</u> ¹ Add 'P' for in-bowl water probes. (Omit if not desired).	<u>300 watt Electric Heaters.</u> ² Specify: '312' for 12 vdc or '324' for 24 vdc. (Omit if not desired).	<u>Element Filtration Rating.</u> Specify one: '2' for 2 micron, '10' for 10 micron or '30' for 30 micron
¹ Must be used with Water Detection Kit -See Accessories Section. ² Must be used with a Relay Kit -See Accessories Section.			

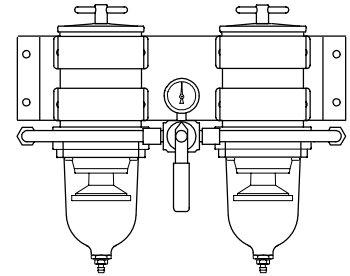

75/900FGX

Replacement Service Elements -For all Model 75/900FGX Series
 SERVICE ELEMENT INCLUDES LID SEAL & T-HANDLE O-RING. Order two (2) per unit.

- 2040SM-OR** 2 Micron (Brown end caps)
 Recommended for Final /Secondary Filtration
- 2040TM-OR** 10 Micron (Blue end caps)
 Recommended for Primary or Secondary Filtration
- 2040PM-OR** 30 Micron (Red end caps)
 Recommended for Primary Filtration* Only.
 *A secondary/final filter is required downstream.

Mounting Hole Pattern -Refer to Turbine Series introduction page for filter dimensions.

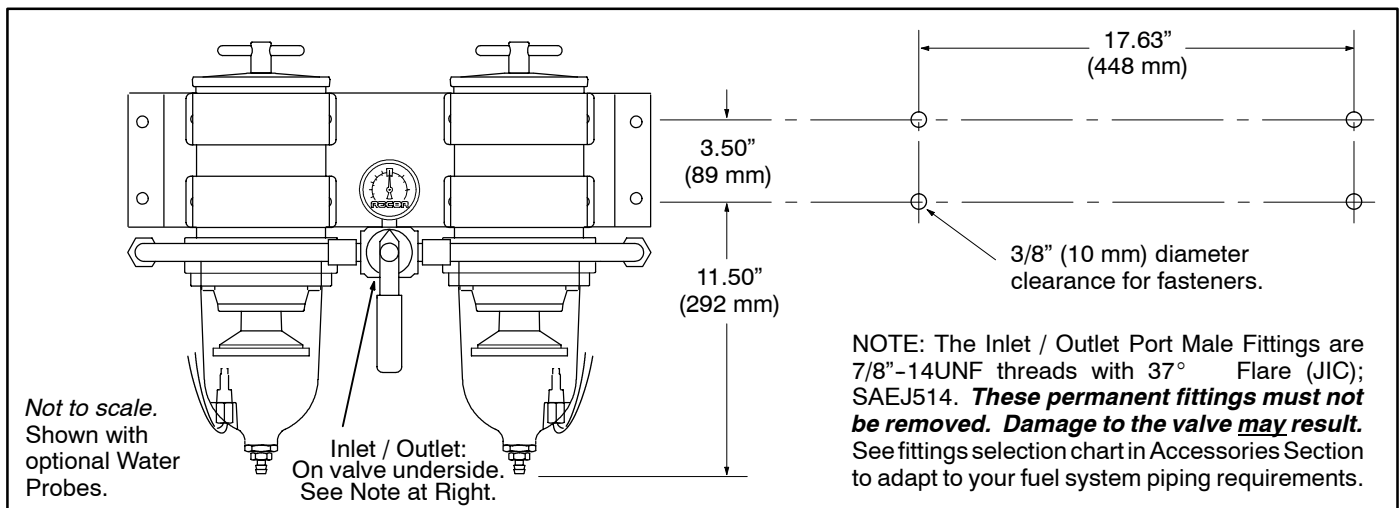

Performance Graphs -These results are from controlled laboratory tests. Filter results may vary by application.

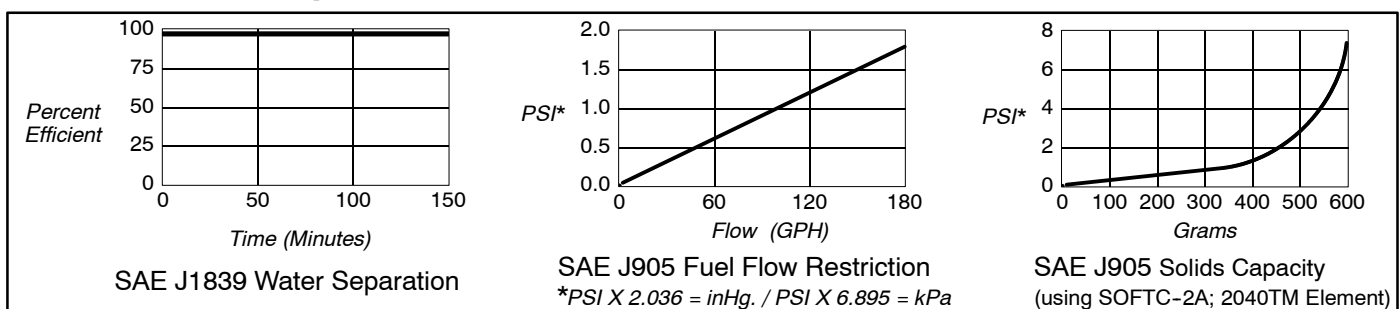
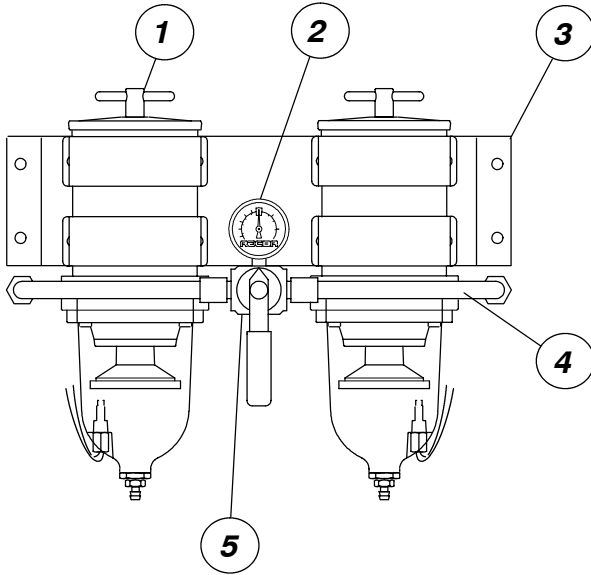

FIGURE 1. 75/900 Series. The circled number corresponds to the item number shown in the parts list below.



Item	Part No.	Description	Case Qty.
1	900FG	Shell. Refer to Model 900FG for a complete parts list	
2	RK19476	Gauge Assembly	1
3	RK19486	Dual unit Bracket	1
4	RK19475	Rigid Tubing Assembly	1
5	RK19473	Valve Assembly	1
	RK19506	Valve Service Kit	1
	19481	Installation Instructions, 75/900FGX	

For Fuel Port Adapter Fittings, Heater Relay Kits, Water Detection Kits, and Manifold Conversion Kits, see the Accessories Section.

For parts not listed, call Racor customer service: (800) 344-3286.

75/900FGXP Model shown

Turbine Series

Model 75/1000FGX

SPECIFICATIONS are found on Turbine Series introduction page.

How to Order -The example below illustrates how the part numbers are constructed.

75/1000FGX	P	312	10
<u>Basic Model</u> 360 GPH For metal bowl unit see <i>Marine Turbine Series</i> in Section Two.	<u>Water Probes.</u> ¹ Add 'P' for in-bowl water probes. (Omit if not desired).	<u>300 watt Electric Heaters.</u> ² Specify: '312' for 12 vdc or '324' for 24 vdc. (Omit if not desired).	<u>Element Filtration Rating.</u> Specify one: '2' for 2 micron, '10' for 10 micron or '30' for 30 micron
¹ Must be used with Water Detection Kit -See Accessories Section. ² Must be used with a Relay Kit -See Accessories Section.			

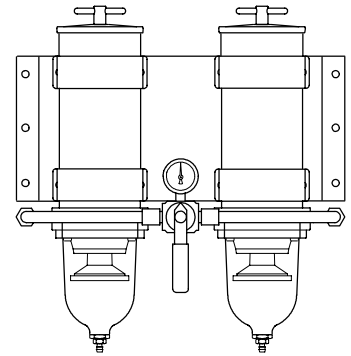

75/1000FGX

Replacement Service Elements -For all Model 75/1000FGX Series
SERVICE ELEMENT INCLUDES LID SEAL & T-HANDLE O-RING. Order two (2) per unit.

2020SM-OR	2 Micron (Brown end caps) Recommended for Final /Secondary Filtration
2020TM-OR	10 Micron (Blue end caps) Recommended for Primary or Secondary Filtration
2020PM-OR	30 Micron (Red end caps) Recommended for Primary Filtration* Only. *A secondary/final filter is required downstream.

Mounting Hole Pattern -Refer to Turbine Series introduction page for filter dimensions.

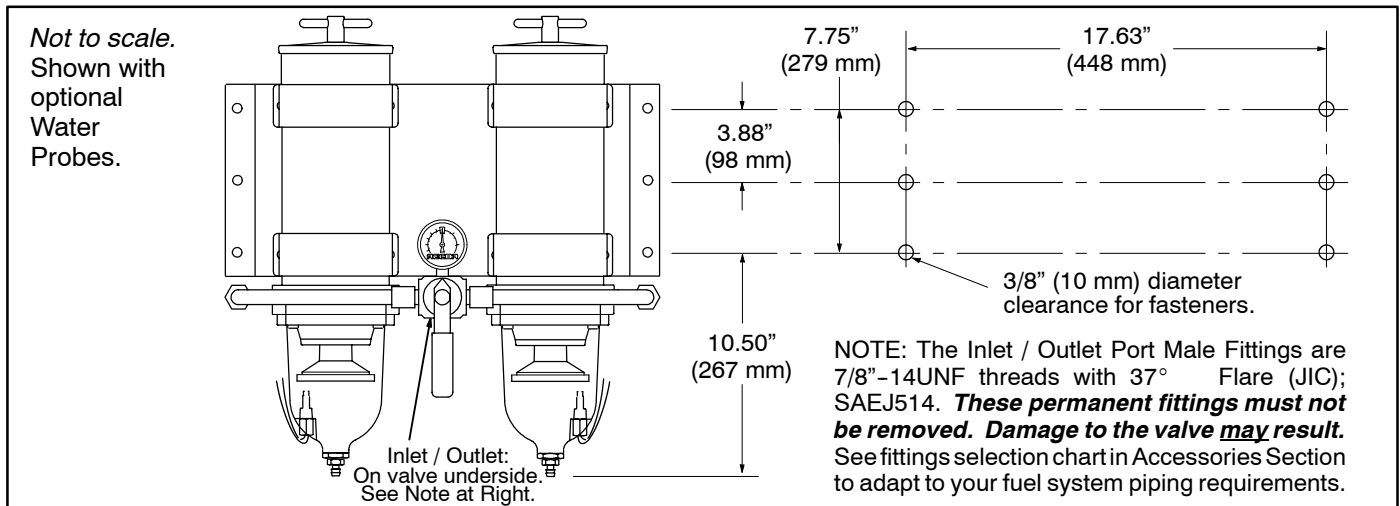

Performance Graphs -These results are from controlled laboratory tests. Field results may vary by application.

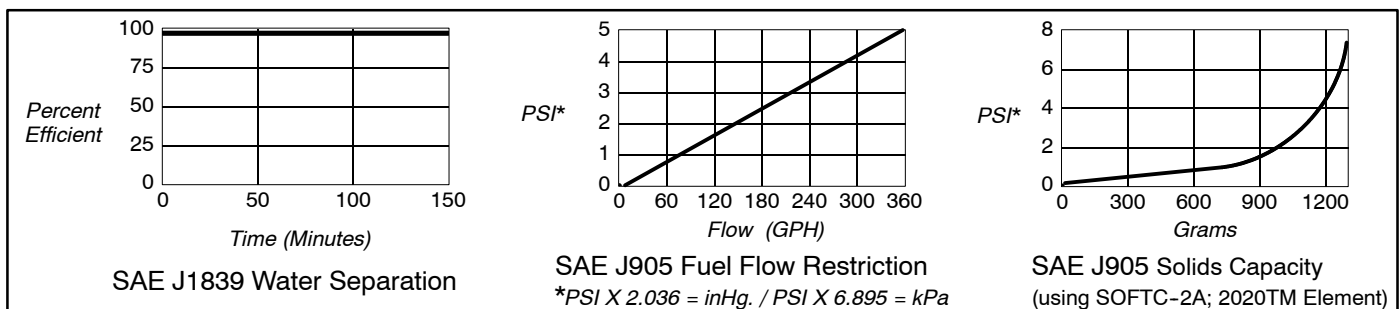
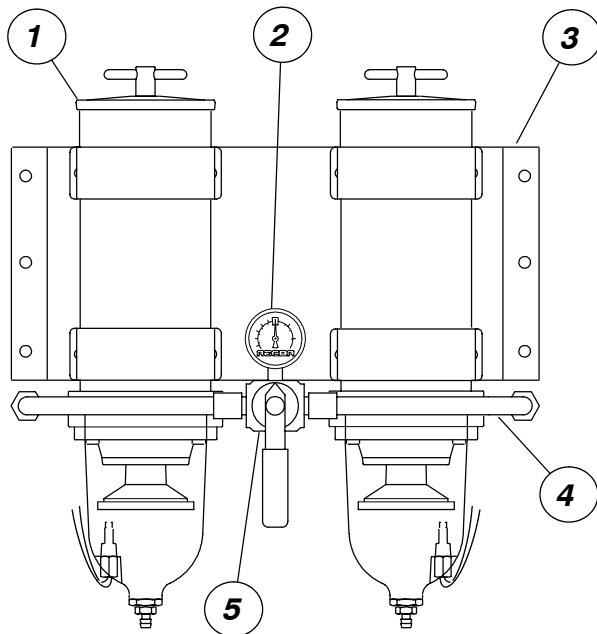

FIGURE 1. 75/1000 Series. The circled number corresponds to the item number shown in the parts list below.



75/1000FGXP Model shown

Item	Part No.	Description	Case Qty.
1	1000FG	Shell. Refer to Model 1000FG for a complete parts list	
2	RK19476	Gauge Assembly	1
3	RK11-1777	Dual unit Bracket	1
4	RK19475	Rigid Tubing Assembly	1
5	RK19473	Valve Assembly	1
	RK19506	Valve Service Kit	1
	19481	Installation Instructions, 75/1000FGX	

For Fuel Port Adapter Fittings, Heater Relay Kits, Water Detection Kits and Manifold Conversion Kits, see the Accessories Section.

For parts not listed, call Racor customer service: (800) 344-3286.

Turbine Series

Model 77/1000FG

SPECIFICATIONS are found on *Turbine Series introduction page*.

How to Order -The example below illustrates how the part numbers are constructed.

77/1000FG	P	312	10
<u>Basic Model</u> 540 GPH For metal bowl unit see <i>Marine Turbine Series</i> in Section Two.	<u>Water Probes.</u> ¹ Add 'P' for in-bowl water probes. (Omit if not desired).	<u>300 watt Electric Heaters.</u> ² Specify: '312' for 12 vdc or '324' for 24 vdc. (Omit if not desired).	<u>Element Filtration Rating.</u> Specify one: '2' for 2 micron, '10' for 10 micron or '30' for 30 micron
¹ Must be used with Water Detection Kit -See Accessories Section. ² Must be used with a Relay Kit -See Accessories Section.			

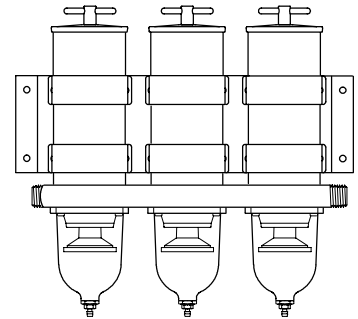

77/1000FG

Replacement Service Elements -For all Model 77/1000 Series
 SERVICE ELEMENT INCLUDES LID SEAL & T-HANDLE O-RING. Order three (3) per unit.

2020SM-OR	2 Micron (Brown end caps) Recommended for Final /Secondary Filtration
2020TM-OR	10 Micron (Blue end caps) Recommended for Primary or Secondary Filtration
2020PM-OR	30 Micron (Red end caps) Recommended for Primary Filtration* Only. *A secondary/final filter is required downstream.

Mounting Hole Pattern -Refer to *Turbine Series introduction page* for filter dimensions.

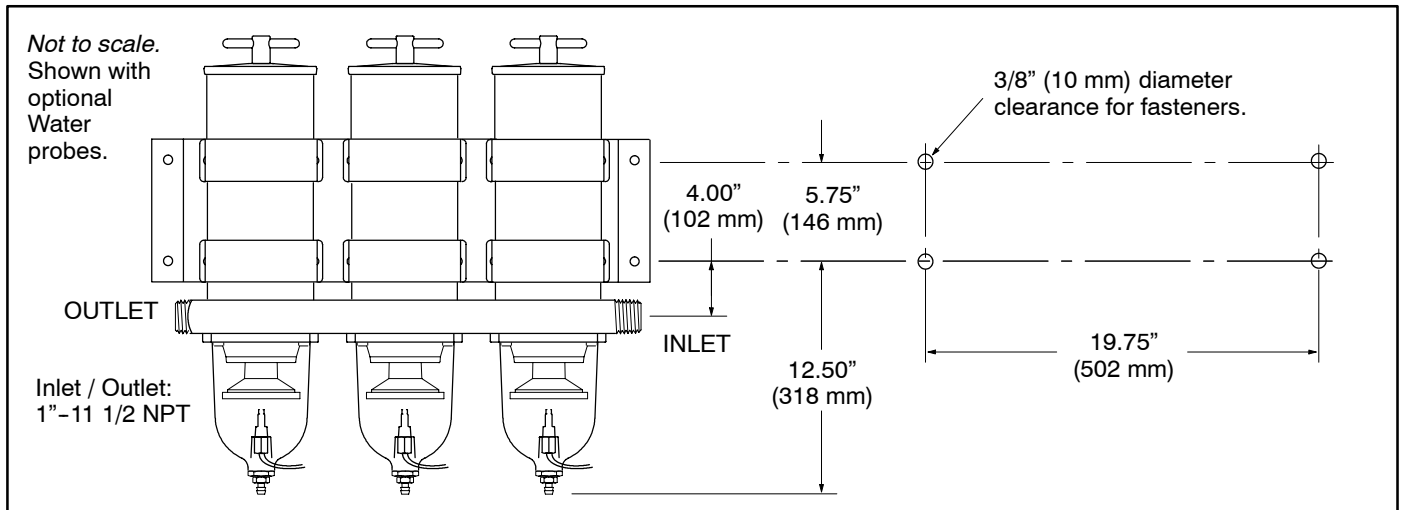

Performance Graphs -These results are from controlled laboratory tests. Field results may vary by application.

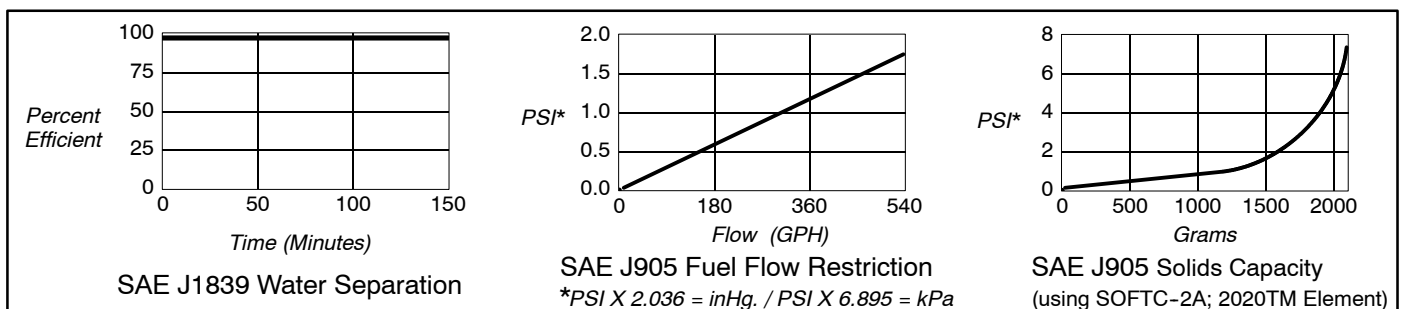
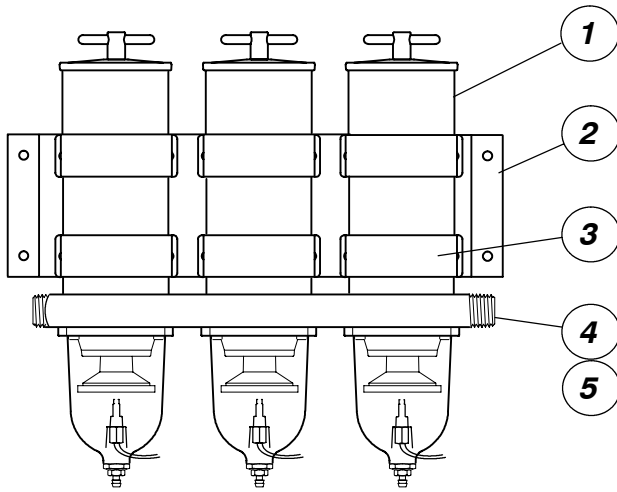

FIGURE 1. 77/1000 Series. The circled number corresponds to the item number shown in the parts list below.



Item	Part No.	Description	Case Qty.
1	1000FG	Shell. Refer to Model 1000FG for a complete parts list	
2	18998	Triple Bracket	1
3	RK11815-101	Clamp Bracket Assembly	1
4	11076	1" Inlet & Outlet Manifolds	1
5	11071	Straight Fitting (not shown)	1
	11-1825	Installation Instructions, 77/1000FG	

For Heater Relay Kits, Water Detection Kits and Manifold Conversion Kits, see the Accessories Section.

For parts not listed, call Racor customer service: (800) 344-3286.

77/1000FGP Model shown

Turbine Series

Model 79/1000FGV

SPECIFICATIONS are found on Turbine Series introduction page.

How to Order -The example below illustrates how the part numbers are constructed.

79/1000FGV	P	312	10
<u>Basic Model</u> 540 GPH For metal bowl unit see <i>Marine Turbine Series</i> in Section Two.	<u>Water Probes.</u> ¹ Add 'P' for in-bowl water probes. (Omit if not desired).	<u>300 watt Electric Heaters.</u> ² Specify: '312' for 12 vdc or '324' for 24 vdc. (Omit if not desired).	<u>Element Filtration Rating.</u> Specify one: '2' for 2 micron, '10' for 10 micron or '30' for 30 micron
¹ Must be used with Water Detection Kit -See Accessories Section. ² Must be used with a Relay Kit -See Accessories Section.			

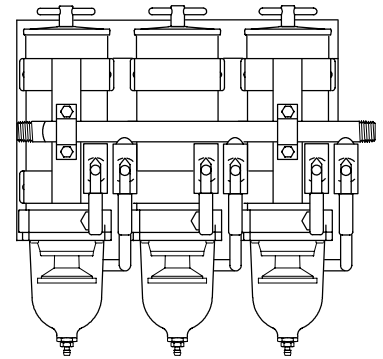

79/1000FGV

Replacement Service Elements -For all Model 79/1000FGV Series
 SERVICE ELEMENT INCLUDES LID SEAL & T-HANDLE O-RING. Order three (3) per unit.

- 2020SM-OR** 2 Micron (Brown end caps)
Recommended for Final /Secondary Filtration
- 2020TM-OR** 10 Micron (Blue end caps)
Recommended for Primary or Secondary Filtration
- 2020PM-OR** 30 Micron (Red end caps)
Recommended for Primary Filtration* Only.
*A secondary/final filter is required downstream.

Mounting Hole Pattern -Refer to Turbine Series introduction page for filter dimensions.

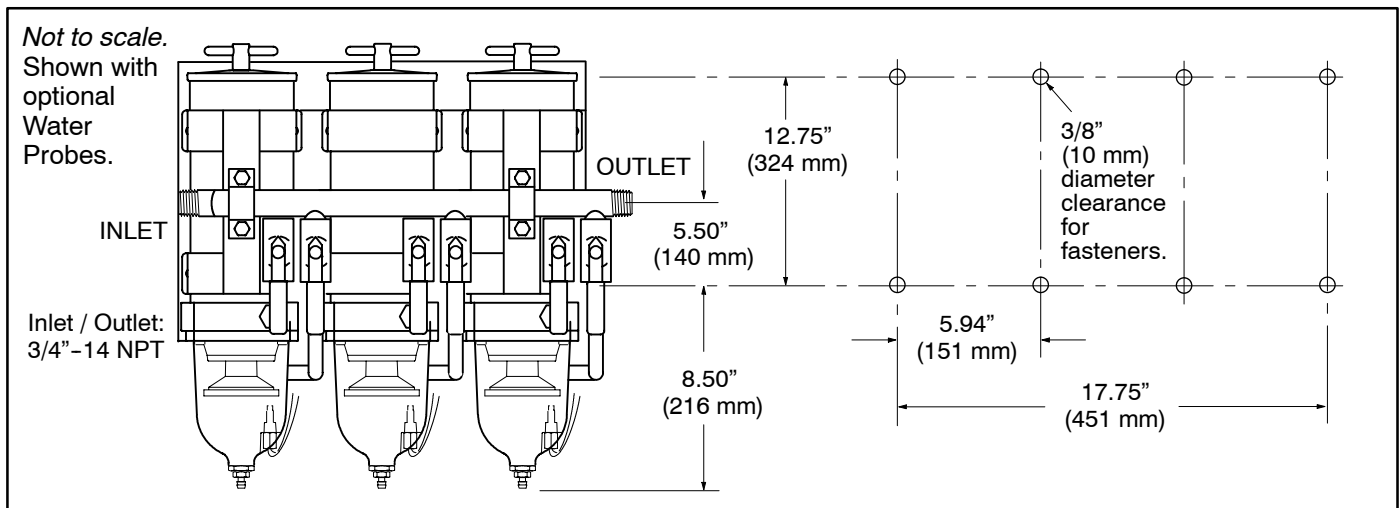

Performance Graphs -These results are from controlled laboratory tests. Field results may vary by application.

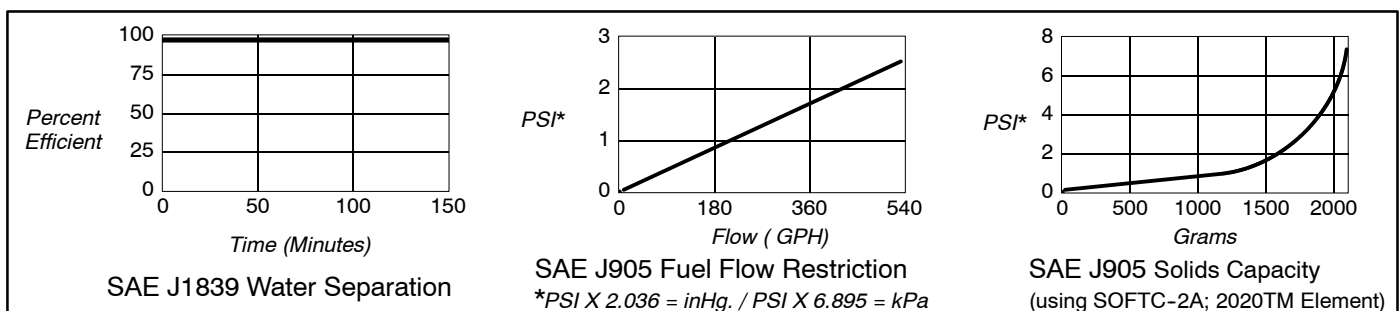
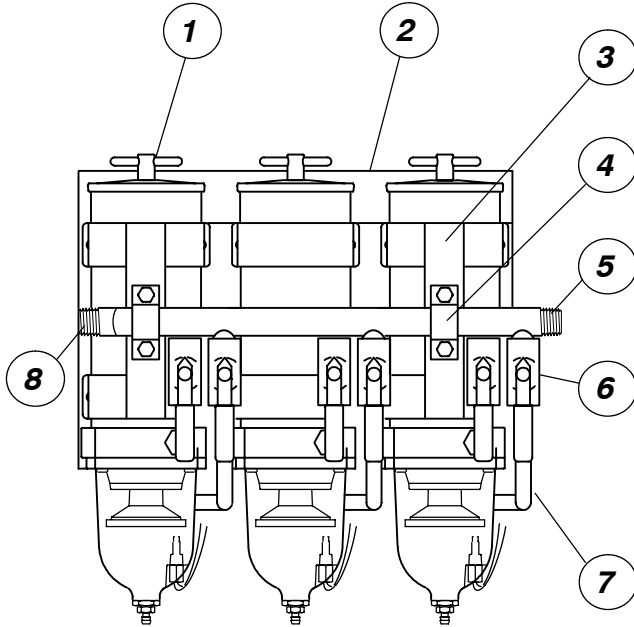

FIGURE 1. 79/1000 Series. The circled number corresponds to the item number shown in the parts list below.



Item	Part No.	Description	Case Qty.
1	1000FG	Shell. Refer to Model 1000FG for a complete parts list	
2	11-1632	Triple Bracket	1
3	11895	Clamp Bracket	1
4	11-1761	'U' Bracket	1
5	19461	Outlet Manifold	1
6	RK11073	1/2" Ball Valve	1
7	11-1626	Formed Tubing Assembly	1
8	19460	Inlet Manifold	1
	11-1821	Installation Instructions, 79/1000FGV	

For Heater Relay Kits, Water Detection Kits and Manifold Conversion Kits, see the Accessories Section.

For parts not listed, call Racor customer service: (800) 344-3286.

79/1000FGVP Model shown

In-Depth Guide

Fuel Filter Troubleshooting:

On new installations the unit must be filled with fuel and the fuel system must be adequately primed following the **engine manufacturer's recommendation**, if applicable. On existing installations difficulties are usually associated with improper priming procedures or damage to the unit or fuel system. The result is either internal air suction or external fuel leakage. Correct external fuel leaks immediately. These conditions will result in reduced engine performance such as: hard starting, stalling, reduced power, and other associated problems. Diagnosis should be in the following steps:

1. Check fuel tank level and make sure any fuel delivery valves are in the position, as applicable.
2. Ensure the T-handle, lid vent (if applicable), bowl fasteners, and fuel fittings are tight. The bowl drain must be closed.
3. If the Racor element is new, check potential restriction at the fuel tank draw tube. An in-tank strainer may be plugged.
4. Review some of the workings of the units below to possibly uncover other solutions.

How the unit works: Refer to the Turbine Series *Selection* page found at the beginning of this section.

Correct Application: It is very important that the unit is not 'under specified' for the application. The maximum fuel flow rating of the unit must not be exceeded. Doing so will reduce efficiency and de-gas (pull air from) the fuel. Refer to the Turbine Series *Introduction* page found at the beginning of this section for maximum flow rates.

Filter Elements: Replacement elements are available in 2, 10, and 30 micron ratings. Filtration needs are based on application, fuel quality, maintenance schedules, and operating climates. Refer to the Turbine Series *Selection* page found at the beginning of this section for specifying the correct micron rating.

A simple rule to remember: The finer the filtration, the more frequent the filter change. *Carry extra filters with your equipment.* When clogged to the maximum capacity, elements will have a brown to black color or tar like contaminants may be present - this is normal. An appearance of a multi-colored slime (which may have a foul odor) is an indication of microbiological contamination. This condition must be treated immediately. Refer to the *Racor Additives* Section for a biocide treatment. Severe conditions must be corrected by a repair facility.

Note: *Never operate your system without the filter in place (unless required for temporary, emergency operation).*

Options

Water Probes: This feature alerts the operator of a high-water condition. The bowl is then drained of water at the earliest convenience. Note: A Racor Water Detection Module is needed to work with the in-bowl probe (except RK30880). The unit should activate when the water reaches the probe tips (and when they measure between 47,000 and 100,000 ohms of resistance, depending on the detection module used). If not, the tips may be fouled with a coating. Remove the probe and clean the tips with a cloth. Run a jumper wire between the tips with the ignition on to test the system. Difficulties usually lie in the wire connections, power source, or an independent ground.

Heaters: In-filter heaters are starting aids only, but may be left on during cold operations. The 300 watt heater (500 models are 150 watts) is an extremely reliable option, but **MUST** be powered via a relay switch because of the initial amperage surge at start-up: 25 amps at 12 vdc and 12.5 amps at 24 vdc (500 models: 12 vdc=12.5, 24 vdc=6.3). They do not activate unless the fuel is below 35°F (2°C) and automatically deactivate at 80°F (28°C). Power draw reduces as the fuel gets warmer.

Testing: *The heater can only be tested when the thermostat is closed (fuel temperature is below 35°F):* With a voltmeter attached to external wiring, and engine off, power should drop when heater is switched on. (Option: Remove the heater or place the empty Racor unit in a freezer until the temperature is under 35°F. Remove the unit and repeat above test).

Multiplex Models: The above information applies to all multiplex (manifold) models. Additionally, these models feature plumbing to join or control each filter unit. It is normal for one filter to plug or accumulate water before another. This is true to the fact that flow follows the path of least resistance. In operation, multiplex units may be used with all filters on-line (for maximum flow capacity) or with one filter off-line and the other in stand-by mode. When a problem develops and can not be traced to the items in the *Quick-Help Guide*, systematically check each connection of the plumbing by tightening or coating with a silicon sealant. On MAX/FGX units, ensure the tubing nuts are tight and the collar nut under the selector valve handle has not been loosened. Also, do not remove the port fittings as these hold the internal components in place. To adapt your fuel system, select the appropriate adapter fittings from the *Accessories* Section.

Diesel Fuel Troubleshooting: Refer to the *Racor Additives* Section for diesel fuel treatments and conditioners.

For additional assistance, call your Racor dealer or call Racor customer service at (209) 521-7860 or (800) 344-3286, 6:00 AM to 5:00 PM, Pacific Time, or e-mail us from our website, www.parker.com/racor.

Quick Help Guide: All Models

ALL RACOR TURBINE MODELS ARE 100% TESTED TO ENSURE A LEAK-PROOF, QUALITY PRODUCT.

In the event difficulties are experienced with your unit or a problem appears to prevent the engine from running smoothly, follow the quick-help illustration below or refer to the detailed procedures on the following page. For multiplex units, additional plumbing joints associated with your particular unit may be a potential leak spot due to damage during transit. See 'Multiplex Models' on the next page.

Note: Apply Parker Super O-lube or equivalent to all seals at major attachment points to maintain integrity, seal elasticity, to fill small voids and provide protection from degradation.

Perform the following checks with the engine off (and applicable valves closed). For replacement parts, refer to your specific model in this section.

Hand tighten the T-handle only!
Specification: 80-90 in.lbs.

If the element is changed or the unit drained for any reason, repriming (fill with fuel) the unit may be necessary. Fill to just above the top of the element before replacing the lid.

If the carriage bolt has been loosened, do not overtighten it as this may distort the cylinder roundness.

The four self-tapping capscrews must not be overtightened to avoid stripping out the body threads. After disassembly, start threads by hand prior to using tools. To ensure a good seal between the bowl and the body, use Parker Super O-lube on the seal.
Specification: 55-65 in.lbs.

The hollow aluminum check ball floats up against the seal when the fuel is stopped thus preventing fuel bleed-back. If your unit loses prime, inspect upstream hose connections first otherwise, disassemble the unit and inspect the seal and ball.

Drain water (if present) before it gets to this level.

Air bubbles or fuel leakage appearing from the drain may indicate that the drain is not closed completely or that the seals have been clogged with contaminants. Tighten, or disassemble and inspect.
Specification: 30-35 in.lbs.

If the self-venting drain will not work when opened, it may be clogged. Cycle the drain (open-close) or attach a hose and briefly apply air (<2-3 PSI) to dislodge the contaminants.

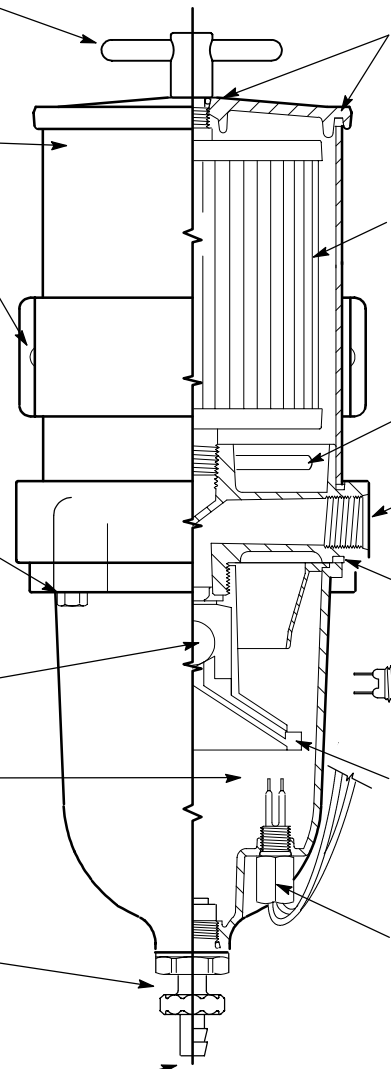

A damaged or worn seal, or dirt, will allow air ingestion. Inspect and replace the seal if needed. Clean the sealing surfaces of dirt or debris every time the element is replaced. Use Parker Super O-lube on seals.

The element should be replaced every 10,000 miles, every 500 hours, every other oil change or at the first indication of power loss, whichever occurs first. For Construction and Agricultural use, change the filter every 300 hours. See 'Filter Elements' on the next page.

See 'Heaters' on previous page.

SAE O-ring ports should have a smooth angled seat for sealing. Do not scratch this surface. Check O-ring for damage.

A damaged seal will allow air ingestion or fuel leakage. Inspect and replace if needed.

The Heater Feedthru O-ring must not be damaged or swollen. Tighten snugly.
Specification: 15-20 in.lbs.

Air bubbles or fuel leakage appearing from the turbine are an indication of an upstream leak between the Racor inlet and the fuel tank pickup tube.

Water probes (if equipped) should activate when water contacts the tips. See 'Water Probes' on next page. Air bubbles or fuel leakage appearing from the probe may indicate that the probe is loose or that the O-ring is damaged. Tighten, or disassemble and inspect.
Specification: 15-20 in.lbs.

Selection Information

General

The diesel fuel heaters apply heat to the fuel incoming from the fuel tank to enable it to flow more freely on its way to the primary fuel filter/water separator. Heating the fuel dissolves paraffin wax crystals (and ice) that form when diesel fuel is chilled thus enabling water separators to work more efficiently and to prevent fuel filters from plugging with wax and/or ice crystals.

There are two types of diesel fuel heater units available: electric heated and coolant heated. The electrical heaters use vehicle electrical power to operate the heating elements. The coolant heaters use hot engine coolant as a heat source and transfer that heat to the fuel.

1. DETERMINE THE ENGINE HORSEPOWER.

(The fuel heaters have been matched to fuel flow rate using engine horsepower)

2. DETERMINE THE TYPE OF HEATER PREFERRED: NOMAD OR THERMOLINE.

Both types of heaters are located in the fuel stream between the fuel tank and the primary fuel filter/water separator.

The *Nomad* heaters are small and may be mounted to a fixed surface out of the wind stream.

These are ideal for applications where space is limited.

The *Thermoline* electric heaters are *in-line* units that actually replace a section of fuel hose.

These units are also well suited to replace existing fuel hose that may be somewhat exposed to the wind stream: like fuel tank crossover lines, fuel lines from tank to engine frame, etc.

3. DETERMINE THE TYPE OF HEATER POWER: COOLANT OR ELECTRICAL.

Some criteria that may affect this decision are:

(1) electrical hookup may be easier;

(2) alternator is capable of the additional load;

(3) alternator or electrical system is already at capacity, therefore coolant heated is preferred.

Note: For very severe cold operating climates, a Nomad coolant heater and a Thermoline in-line electric heater could be used.

Using this information, select a unit from the following page index. Also, refer to the specific heater information page which follows.

Model Illustrations

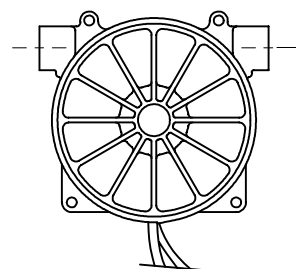

Nomad™ Electric Heaters

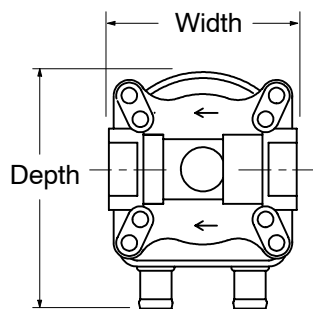

Nomad™ Coolant Heaters

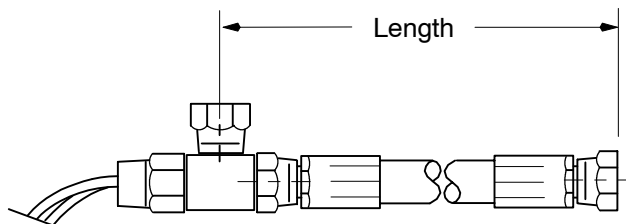

Thermoline™ Electric Heater

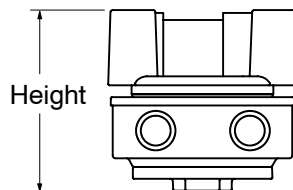
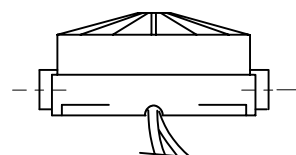

Special Notes

1. For additional information and availability, contact customer service at: (800) 344-3286, 6 AM to 5 PM, Pacific Time.

Specifications

BASIC MODELS		Nomad Electric				Nomad Coolant		Thermoline Electric		
		14278	14279	14257	14261	320HTR4, 320HTR4T		HEATER150, HEATER300, HEATER500		
Engine Horsepower	kW	up to 200 up to 149		200 to 300 149 to 224		up to 300 up to 224		Cars & Trucks	100-200 75-149	over 200 over 149
Power output	Watts	300	300	500	500	N/A	N/A	150	300	500
Voltage	VDC	12	24	12	24	N/A	N/A	12	12 or 24	12 or 24
Amperes draw (nominal)		21.4	10.7	35.7	17.9	N/A	N/A	10.7	21.4/10.7	35.7/17.9
Alternator Rating, Min. ¹		65	40	75	45	N/A	N/A	55	65 / 40	75 / 45
Internal Thermostat		Yes	Yes	In-cab control	In-cab control	No	Yes	In-cab control	In-cab control	In-cab control
Port Size, Fuel	SAE	7/8"-14	7/8"-14	7/8"-14	7/8"-14	7/8"-14	3/8"NPT	7/8"-14 ²	7/8"-14 ²	7/8"-14 ²
Port Size, Coolant		N/A	N/A	N/A	N/A	5/8" I.D.	Hose	N/A	N/A	N/A
Height	in.	2.56	2.56	2.56	2.56	3.82	3.82	N/A	N/A	N/A
	mm	65	65	65	65	97	97			
Width (Length)	in.	5.75	5.75	5.75	5.75	3.88	3.88	4 ft.	7 ft.	10.5 ft.
	mm	146	146	146	146	99	99	1.22 M	2.13 M	3.20 M
Depth	in.	5.38	5.38	5.38	5.38	4.72	4.72	N/A	N/A	N/A
	mm	137	137	137	137	120	120			
Weight (dry)	lbs.	1.7	1.7	1.7	1.7	2.1	3.0	3.4	6.3	8.4
	kgs.	.77	.77	.77	.77	.95	1.36	1.52	2.86	3.81

¹ For operating temperatures, refer to the specific unit page that follows.

¹ For on-highway trucks, assuming all tractor lights and blowers are on. Use of more accessories will require a higher rating.

² Thermoline fittings are 45° female swivel (SAEJ512). Do not adapt to JIC 37° fittings (SAEJ514). See Thermoline Section.

SPECIFICATIONS are found on Diesel Fuel Heaters introduction page.

How to Order

Up to 200 HP, 300 Watts	200 to 300 HP, 500 Watts
<p>14278 -12 volts d.c., 300 watts. 14279 -24 volts d.c., 300 watts. Aluminum die-cast body and high impact glass-filled nylon cover. Internal automatic thermostat controlled. Fittings and mounting hardware included. Note: Optional relay kit RK11861 (12vdc) or RK11862 (24vdc) may be required, not included. See Accessories.</p>	<p>14257 -12 volts d.c., 500 watts. 14261 -24 volts d.c., 500 watts. Aluminum die-cast body and high impact glass-filled nylon cover. Fittings and mounting hardware included. Controlled by provided In-cab controller / relay RK14280-12 (12vdc) or RK14280-24 (24vdc).</p>

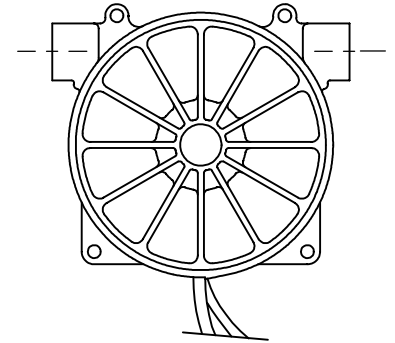

Mounting Hole Pattern

-Refer to Diesel Fuel Heaters introduction page for more information.

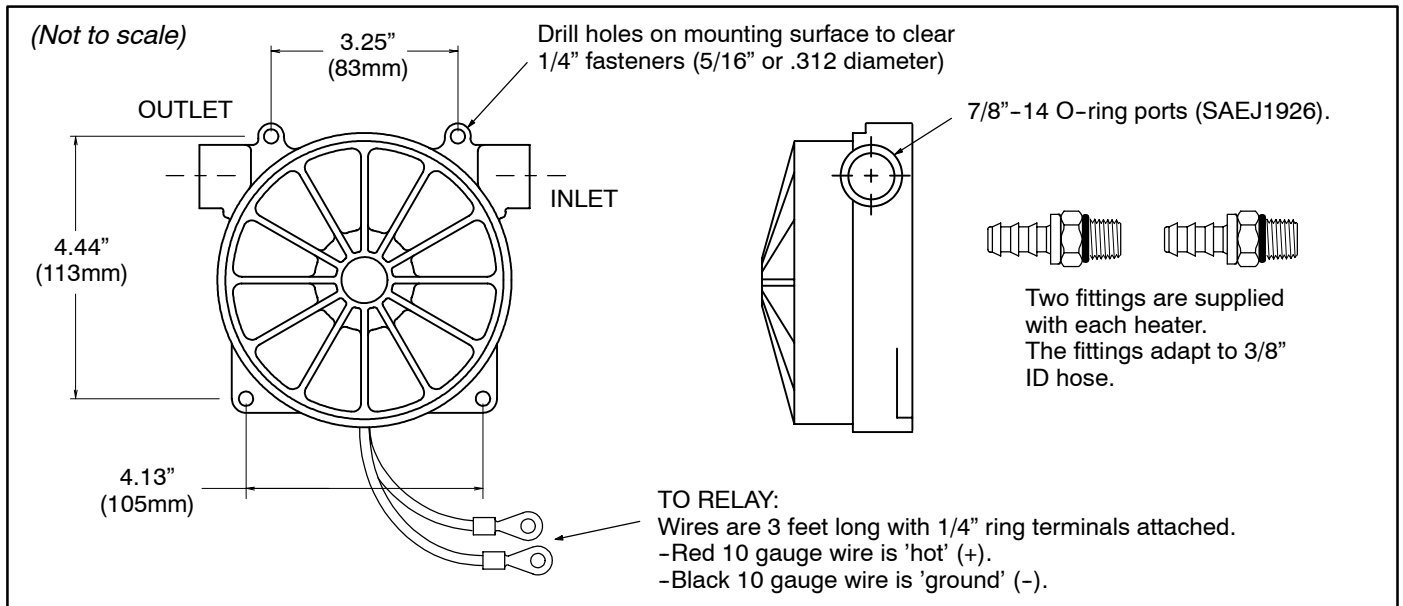

Performance Graphs

-These results are from controlled laboratory tests. Field results may vary.

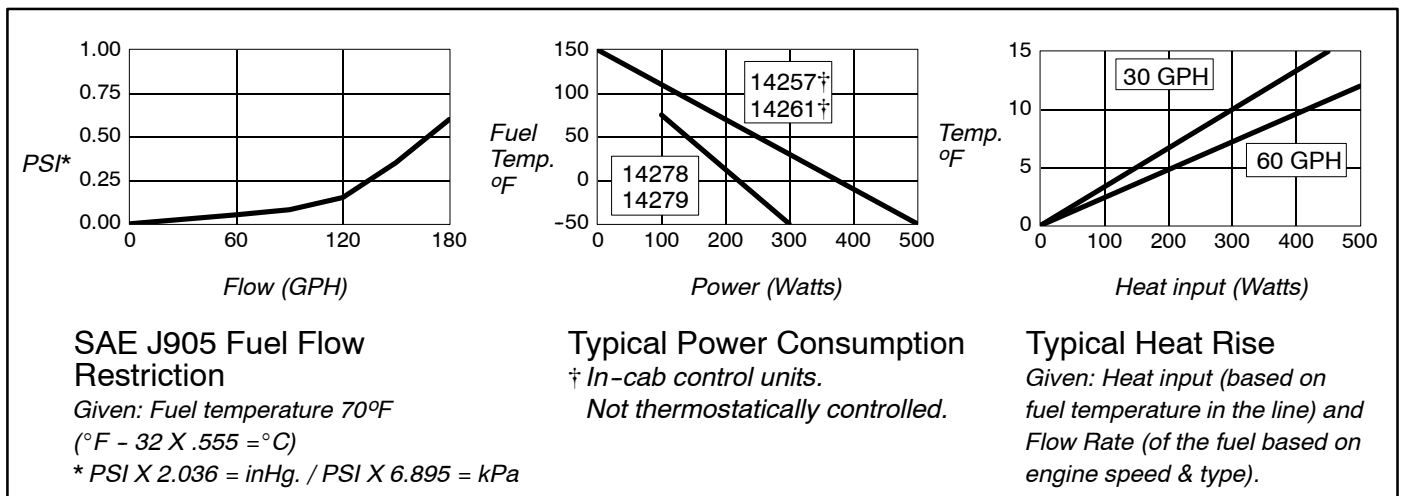

SPECIFICATIONS are found on Diesel Fuel Heaters introduction page.

How to Order -The example below illustrates how the part numbers are constructed.

320HTR4	T
<p><u>Basic Model:</u> Coolant heat exchanger type unit. Use with engines up to 300 horsepower. Aluminum die-cast body and plated steel coolant heat exchanger. Accepts 5/8" I.D. coolant hoses. Mounting bracket and hardware included.</p>	<p><u>Optional Automatic Thermostat:</u> Specify 'T' for this option, only. Installed by the factory, when the fuel temperature is below 60°F, the thermostat is open to heat fuel. As the fuel temperature approaches 80°F, the thermostat closes, allowing the fuel to by-pass the heat exchanger.</p>

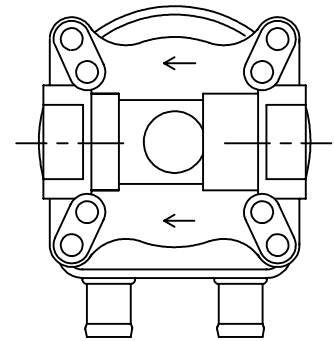

Top View

Mounting Hole Pattern

-Refer to Diesel Fuel Heaters introduction page for more information.

(Not to scale)

FUEL PORTS
320HTR4:
7/8"-14 O-ring port (SAEJ1926)

320HTR4T:
3/8"-18 NPTF (SAEJ476)

Fuel Outlet Fuel Inlet

Coolant Inlet Coolant Outlet

2.38" (60mm)

1.79" (45mm)

Drill holes to clear 3/8" fasteners.

Note: If drilling holes into the frame rail is not desired or possible, Use Racor's universal frame rail mounting bracket (RK11-1518). See Accessories Section for more information.

Performance Graphs

-These results are from controlled laboratory tests. Field results may vary.

SAE J905 Fuel Flow Restriction
Given: Fuel temperature 70°F.
(°F - 32 X .555 = °C)
* PSI X 2.036 = inHg. / PSI X 6.895 = kPa

Typical Flow vs Heat Rise
Given: Fuel inlet temperature, -9°F.
Coolant inlet temperature, +180°F.

Typical Differential Pressure vs Flow
† Given: Fuel inlet temperature is +85°F (320HTR4T.)
‡ Given: Fuel inlet temperature is +40°F, Heater on.

SPECIFICATIONS are found on Diesel Fuel Heaters introduction page.

How to Order -The example below illustrates how the part numbers are constructed.

HEATER	500	24V
<p><u>Basic Thermoline designation</u> The unit uses 'oversize' No.10 high quality fuel hose with an internal heating element. The heater element is a conductive polymeric core extruded between two parallel copper bus wires and is infinitely temperature self-regulating. In-cab underdash controller / relay (RK 14280-12 or -24) is included.</p>	<p><u>Specify Heater Power (in Watts)</u> '150' Recommended for cars or trucks. '300' Recommended for engines 100 to 200 horsepower. '500' Recommended for engines over 200 horsepower.</p>	<p><u>Specify Voltage</u> '12V' for 12 volts. '24V' for 24 volts.</p>

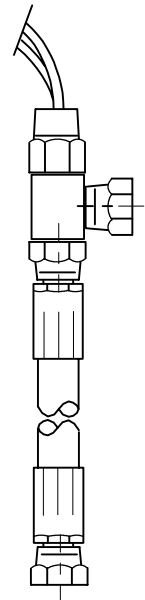

Product Notes -Refer to Diesel Fuel Heaters introduction page for more information.

(not to scale)

NOTE: THE INLET AND OUTLET FITTINGS ARE 45° FLARE.
Do not use with 37° flare fittings. Use an adapter listed below:

- #14201 -45° male by 1/4"NPT male (SAEJ476)
- #14202 -45° male by 3/8"NPT male (SAEJ476)
- #14203 -45° male by 7/8"-14 O-ring male (SAEJ514)

Performance Graphs These results are from controlled laboratory tests. Field results may vary.

Typical Power Consumption
(Power output decreases as fuel temperature rises)
(°F - 32 X .555 = °C)

Typical Heat Rise
-All models.
Given: Heat input (based on fuel temp.in the line) and Flow Rate (of the fuel based on engine speed & type).

Typical Fuel Flow Restriction
Given: Fuel temperature 70°F
* PSI X 2.036 = inHg.
PSI X 6.895 = kPa

Specialty Products

Part No.	Description	Qty.
RK31605	Parker Super O-lube, silicone base, 2 oz. tube	1



Touch-up Paint

Racor coats the exterior of most aftermarket products in four major colors: black, white, gold, and beige using a superior powder coating method. However, during the lifetime of the product minor dings and scratches will appear on the coating. Now, Racor offers our customers the availability of touch up paint for these occasions.

The touch-up colors are available in 1/2 fluid ounce 'bottles' that include an applicator brush built right into the cap. The beige color is unique to Racor and is the only one that must be ordered through customer service. BEIGE is Racor part number RK10221.

The black, white, and gold colors are very good matches and are readily available from the following sources: Auto Zone Stores, Checker/Kragen/Schucks Auto Stores, Grand Auto/Al's Auto Stores, K-Mart, Napa Auto Stores, and Wal-Mart. These three colors are standard Sherwin-Williams Dupli-Color* automotive finish colors already offered to the general public. Source these colors at these locations, as they will not be stocked by Racor.



Part Numbers:

BLACK is Dupli-Color* #SFGM1 (General Motors Black Clearcoat).

WHITE is Dupli-Color* #SFGM153 (General Motors Classic White Clearcoat).

GOLD is Dupli-Color* #SFGM491 (General Motors Gold Clearcoat).

These products have an approximate shelf life of two years if re-sealed correctly and are considered nonhazardous. They may be shipped via all modes without special precautions or paperwork.

*Dupli-Color is a registered trademark of Dupli-Color Products, The Specialty Division, Division of the Sherwin-Williams Co.

New Bowl Removal Wrench

Racor now offers a hand wrench to remove all metal and see-thru spin-on bowls that feature external ribs. This includes the following models: 025, 120, all 200 Series, 300 Series, 400 Series, 600 Series and Navistar metal bowls as used on the 6.9 and 7.3 liter Ford Pickups.

By simply fitting the wrench over the bowl ribs, the bowl can be removed from the replaceable spin-on element with little effort. The wrench is made of a corrosion proof high-impact, high-strength engineered polymer.

Order Part Number 22628.

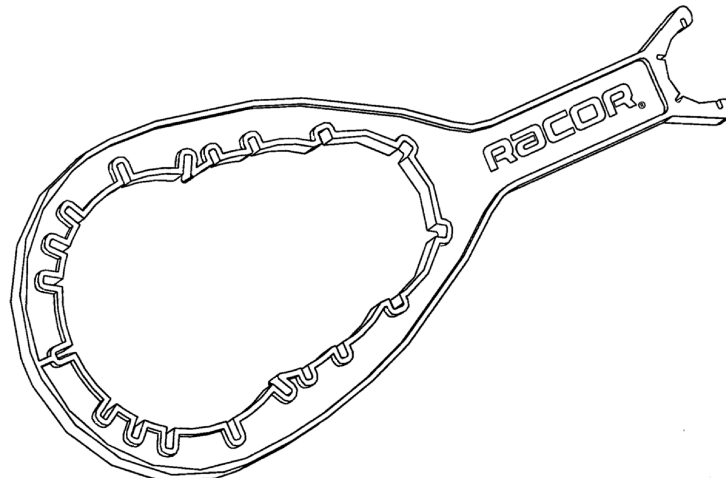

Water Probe Kits

Racor offers a wide selection of water probes, each designed for use with particular models and installation requirements. These probes are available in various configurations to fit every Racor filter/separator. The water probe is only a component in the water detection system and will not work without a Racor electronic detection module.

An electronic detection module analyzes electrical resistance at the probe and determines if water is present. If so, the detection module operates to indicate water, based on its features (see Water Detection Module Kits on the next page). The RK30880 has the electronic detection module built-in to its design and has the simplest installation procedure.

Multiplex units must use one probe for each collection bowl but only one water detection module is needed. Wiring instructions are supplied with each water detection module.

Caution: The water probes must be used with a Racor detection module. Never wire a water probe directly to voltage or other brand detection module.

Use the guide below to find the correct probe for your application.

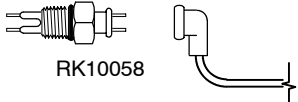
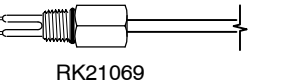
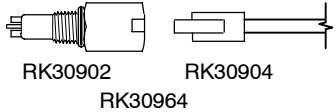
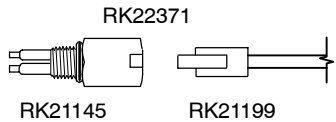
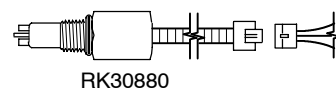
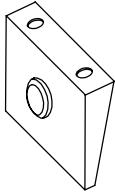
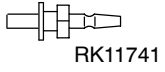
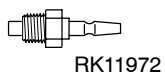

Kit Part No.	Description / Notes	Use with Racor models:	
RK10058	Water Probe Kit. 1/2"-20 threads. Includes detachable two-wire connector.	110 / 120 / 122 Series	
RK21069	Water Probe Kit. 1/2"-20 threads. Wires (two) are potted into housing	500 / 900 / 1000 Series	
RK30964	Water Probe Kit. 1/2"-20 threads. Includes detachable two-wire connector.	200 / 300 / 400 / 600 Series	
RK30902	Water Probe Only.		
RK30904	Connector Only.		
RK22371	Water Probe Kit. 9/16"-18 threads. Includes detachable two-wire connector.	300RC / 400 Series	
RK21145	Water Probe Only.		
RK21199	Connector Only.		
RK30880	Water Probe with Built-in Detection Electronics. 1/2"-20 threads. Includes detachable three-wire connector. Use with either 12 or 24 vdc. Sends a ground signal to the underdash warning light kit (included). Power draw for 12 vdc = 5 milliamps Power draw for 24 vdc = 10 milliamps Max. load = 1 amp	200 / 300 / early 400 500 / 900 / 1000 Series	 
'BULLET-TYPE' PROBES FOR OLDER TURBINE SERIES MODELS.			
RK11741	Water Probe/Terminal Kit. Bullet 'thru-bowl' type, includes 11-1393 connector (1 each).	500 / 900 / 1000 early see-thru bowls	
RK11972	Water Probe/Terminal Kit. Bullet 'thru-bowl' type, includes 11-1393 connector (1 each).	500 / 900 / 1000 early metal bowls	 11-1393

Water Detection Modules and Kits

Racor Water Detection Kits are available in a wide selection for various installation requirements. Under dash, in-dash and remote mount, these solid-state units may be used with any Racor fuel filter/water separator and water probe. They are manufactured using the highest quality materials and are all 100% electrically tested.

An electronic detection module analyzes electrical resistance at the water probe and determines if water is present. If so, the detection module operates to indicate water, based on its features listed below. All units reset automatically after water is removed (unless specified).

Caution: The water probe and detection modules work with 12 or 24 volts, direct current only and should never be wired to other brand modules or household 110 or 220 volts, alternating current. Use the guide below to find the correct detection module for your application.

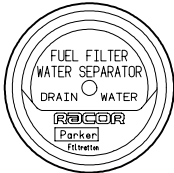
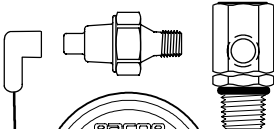
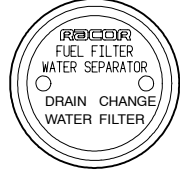
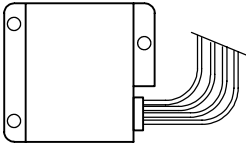
Kit Part No.	Description / Notes	Use with the following voltage:	
RK12870	Under dash Water Detection Module. Light and audio. Illuminates and sounds when water is detected. Water must be drained to reset light and stop horn. Plastic enclosure measures: 1.38" square X 1.25 deep. Power draw is 1 milliamp.	12 vdc	 RK12870 / RK12871
RK12871	Under dash Water Detection Module. Same as above. Power draw is 1 milliamp.	24 vdc	
RK20725	Under dash Mount Water Detection Module. Light only. Green 'ON' lamp illuminates with power and red 'DRAIN' lamp illuminates when water is detected. Initial power-up self diagnosis feature and circuit protection included. Plastic enclosure measures: 2.75" X 1" X 1.5"	12 vdc	 RK20725 / RK20725-24
RK20725-24	Under dash Water Detection Module. Same as above. Power draw is 10 milliamps.	24 vdc	
RK20726	2" Gauge Type Water Detection Module. Light and audio. Red 'DRAIN' lamp illuminates continuously and horn sounds momentarily when water is detected. Initial power-up self diagnosis feature and circuit protection included. Plastic case, satin black dial with white lettering. Power draw for 12 vdc = 3 milliamps, 24 vdc = 13 milliamps.	12 or 24 vdc	 RK20726
RK30056	2" Gauge Type Water Detection Module and Water Probe Kit. (Module RK20726 and Probe RK21069, with 1/2"-20 threads).	12 or 24 vdc <i>Bowl must have water probe port</i>	
RK11-1570	2" Gauge Type Water Detector & Filter Restriction Module. Includes pre-set vacuum switch (7in.Hg.), connector and outlet adapter fitting. Red 'DRAIN' or 'CHANGE FILTER' lamp illuminate continuously and horn sounds momentarily when water is detected. Probe not included. Steel case, black dial with white lettering.	12 or 24 vdc <i>For units with 7/8"SAE ports</i>	 RK11-1570
RK14329	Remote Detection Unit. Sends 12 vdc hot (+) signal when an input ground signal (from a water probe or a vacuum switch -not included) is received. Must be used with a relay to power a horn or indicator lamp (if draw is over 1 amp). Plastic enclosure measures: 3" X 2.5" X .75"	12 vdc	
RK14321	Remote Detection Unit. Same as above but sends 24 vdc hot (+) signal.	24 vdc	
RK14332	Under dash mount. Same as RK14329 but sends a ground (-) signal. Enclosure size is same as RK20725, above.	12 vdc	RK14329 / RK14321

Vacuum / Compound Gauge Kits

Vacuum and Compound (vacuum/pressure) gauges and related hardware is available to monitor element condition. As the filter element slowly becomes clogged with contaminants the restriction (resistance to flow) increases. The fuel pump still tries to draw fuel (suction) but because of this restriction less fuel is delivered to the engine and instead more air is pulled from it (fuel de-gassing). These results can cause the engine to lose power and eventually stall.

By installing a vacuum gauge in your fuel system (at the outlet side of the Racor filter) visual monitoring of element condition is possible at a glance. At the first indication of decreased performance, note the dial reading or apply the 'red line' decal provided with most kits. This will assist in knowing when to change the filter at the next interval.

Note: Intervals of element changeout may vary depending on fuel cleanliness. Always keep a spare Racor element on hand. Multiplex units other than FGX/MAX units may add a vacuum gauge to the outlet by installing a T-fitting.

Compound gauges are recommended for applications where pressure is occasionally present. These conditions are typically a result of 'head' pressure which is present in overhead fuel tank installations. Whatever the reason, compound gauges should be used because damage may result if a straight vacuum only gauge is used.

After September 1999, Racor converted many liquid-filled gauges to new silicone dampened movement. This new 'dry' technology provides a vibration resistant design that never leaks fluid or requires adjustments due to temperature or altitude variations.

Liquid filled (glycerin) gauges are recommended for high-vibration and pulsation applications (not engine mounted). *Note: Internal pressure changes may result in external fluid leakage or failure of the pointer to return to zero with the engine off. Clean any fluid, if evident. Some models may be bled of excess internal pressure (and re-zeroed) by removing the top rubber plug momentarily. Make sure the plug is reinstalled properly-do not push the plug into the gauge housing.*

Note: For severe vibration applications, mount the gauge on a stable, remote location and connect to the source using flexible tubing.

Kit Part No.	Description / Notes	Application:	
RK11233	Vacuum Gauge, Silicone dampened, 2" dial, 0-30 inHg with 1/4"NPT back bracket mount.	Suction	
1606B	Vacuum Gauge Kit. Gauge (RK11233), one 7232-4 & 7234-4 fitting. Instrument panel installation. #4 hose not included.	Suction	
7232-4	Adapter fitting, 1/8"NPTM X #4 (1/4") hose. use with 0102-4-2 fitting, if needed.		
7234-4	Adapter fitting, 1/4" swivel X #4 (1/4") hose. Use with all gauges, if needed.		
0102-4-2	Adapter fitting, straight 1/4"NPTM X 1/8"NPTF For use with 7232-4 / 7234-4 fittings, if needed.		
RK11-1676	Vacuum Gauge, Silicone dampened, 2" dial, 0-30 inHg with 1/4"NPT bottom boss mount.	Suction	
RK11-1669	'T-Handle' Vacuum Gauge Kit. Includes Gauge (11-1676, 1/4" NPT threads) and lid fitting (11-1668, 9/16"-18 SAE threads). <i>Note: Not for use with FF/FE models.</i>	Suction	
RK18-1104	Compound Gauge, liquid filled, 2" dial, 0-30 inHg / 0-30 PSI. 1/4"NPT back bracket mount.	Suction/ Pressure	
RK18-1551	Compound Gauge, liquid filled, 2 1/2" dial, 0-30 inHg / 0-30 PSI. 1/4"NPT back boss mount.	Suction/ Pressure	
RK19476	Compound Gauge, 2" dial, 0-25 inHg / 0-15 PSI. 1/4"NPT bottom boss mount.	Suction/ Pressure	

Vacuum Switch / Connector Kits

Kit Part No.	Description / Notes
RK20163	Vacuum Switch Kit. 12 or 24 vdc, non-adjustable, 'NORMALLY OPEN' contacts close at 7 inHg, 1/8"NPT threads. For use with all models.
RK21030	Vacuum Switch Connector Kit (for use with above). Molded connector with single 18 AWG., 18" blue wire lead.

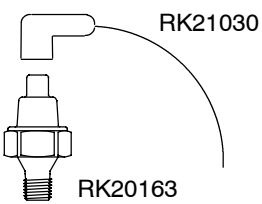

Vacuum Gauge or Switch Adapter Fittings

Fitting Part No.	Old Part No.	Use with:	Thread 1	Fitting end 2	Qty.
913-O6-D6	9010HF6-6DTB	500 Series	9/16"-18	3/8" hose	10
Features 1/8"NPTF to attach vacuum gauge hose fitting.					
911-O8-D8	New	500/4120R	3/4"-16	3/4"-16 SAE	10
911-O10-D10	New	900/1000	7/8"-14	7/8"-14 SAE	10
9040-10-8DT	No change	900/1000	7/8"-14	1/2"-14 NPTF	10
Both above feature 1/4"NPTF to attach vacuum gauge or hose fitting.					

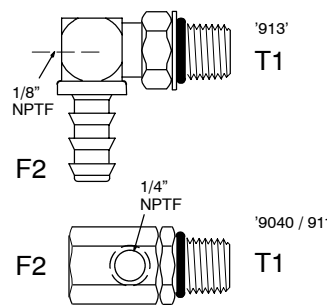

FOR RACOR UNITS WITH TAPERED THREAD (NPTF) PORTS. SOURCE FITTINGS FROM THE PARKER HANNIFIN DIVISION NOTED BELOW. CALL 1-800-C-PARKER FOR THE NEAREST DEALER.

Tee Fitting Description	Hose Products Division	Tube Fittings Division
Port sizes all 3/8"NPTF	#012T-6-6	#3/8MRO
Port sizes all 3/4"NPT	#012T-8-8	#1/2MRO
Adapter Fitting	Hose Products Division	Tube Fittings Division
3/8"NPTF X 1/4"NPTF	#0102-6-4	#3/8X1/4PTR
3/4"NPTF X 1/4"NPTF	#0102-12-4	#3/4X1/4PTR

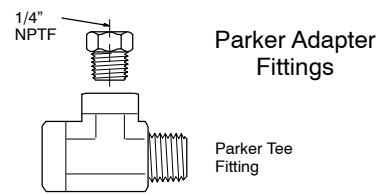

Engine Spin-On Filter 'Block-off' Caps

Kit Part No.	Description / Notes
10202	FORD Spin-On Cap Assembly (not a filter). Threads: 16 X 1.5mm, 3.43" diameter, 4.4" long. Gasket outside diameter: 2.95" X .30 thick.
11548	CUMMINS Spin-On Cap Assembly (not a filter). Threads: 1"-14, 3.63" diameter, 3.5" long. Gasket outside diameter: 2.83" X .22" thick.
22021	FORD Spin-On Cap Assembly (not a filter). Threads: 1"-14, 3.63" diameter, 3.5" long. Gasket outside diameter: 3.60" X .25" thick.

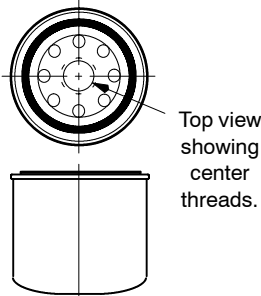

Mounting Bracket Kits

Kit Part No.	Description / Notes	Use with:
15205	Automobile & Light Truck Mounting Kit. Features flexible plated 14 gauge steel arms that can be cut and formed to fit many surfaces. Includes mounting hardware.	110 / 120 / 200 400 / 500 / 600
RK11-1518	Frame Rail Mounting Bracket Kit. Features an adjustable powder coated 10 gauge steel design to fit frame rails up to 10" in height, 3 3/4" wide and 13/16" thick. Includes mounting hardware.	900 / 1000 6400 / Nomad

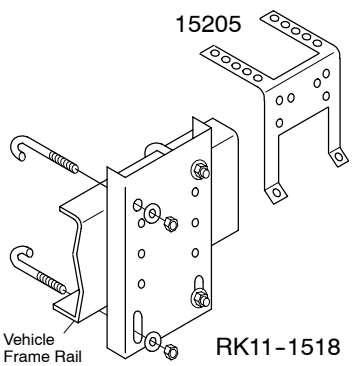

Turbine Series Heater Retrofit Kits

The Racor Turbine Series may be ordered from the factory with either a 12 vdc or 24 vdc fuel heater option to assist in warming fuel for startup during cold weather operations. For continuous cold weather operations, a Racor Diesel Fuel Heater should be included (see table of contents).

Note: For replacement heater discs, or to add a heater to a unit that has a heater feed-thru port in the body (next to the inlet port), refer to your specific model listed prior to this section.

FOR A REPLACEMENT HEATER THAT USES 'BULLET-TYPE' BOWL TERMINALS, OR TO ADD A HEATER TO A UNIT THAT DOES NOT HAVE A HEATER FEED-THRU PORT IN THE BODY, USE THE SELECTION GUIDE BELOW.

Caution: Because of power requirements, a relay may be required when adding a heater to your application. See power requirements in amperes draw, listed. If you are uncertain if your electrical system can provide the additional power, see your vehicle dealer or a qualified electrician. Racor diesel fuel heaters are for 12 or 24 volts, direct current electrical systems, only. Do not attempt to operate the heaters on 110 or 220 volts, alternating current.

500FG Series Kit Part No.	Description / Notes
RK11-1710	Retrofit Kit. Includes See-thru Bowl with self-venting drain, Heater Feed-thru for bowl port, crimp terminals, related seals and instructions. Order Heater below.
RK15310-01	12 vdc, 150 watt Heater Kit. (Max. power draw 10 amps). Heater comes on at 50°F (± 8° F), off at 80° F (± 7° F)
RK15310-02	24 vdc, 150 watt Heater Kit. (Max. power draw 5 amps). Heater comes on at 50°F (± 8° F), off at 80° F (± 7° F)

900FG and 1000FG Series	
Kit Part No.	Description / Notes
RK11-1721-02	Complete Retrofit Kit. Includes See-thru Bowl with self-venting drain, Heater Feed-thru for bowl port, 12 vdc, 300 watt Heater, crimp terminals, related seals and instructions. (Max. power draw 25 amps).
RK11-1721-03	Complete Retrofit Kit. Same as above except 24 vdc, 300 watt Heater. (Max. power draw 13 amps).

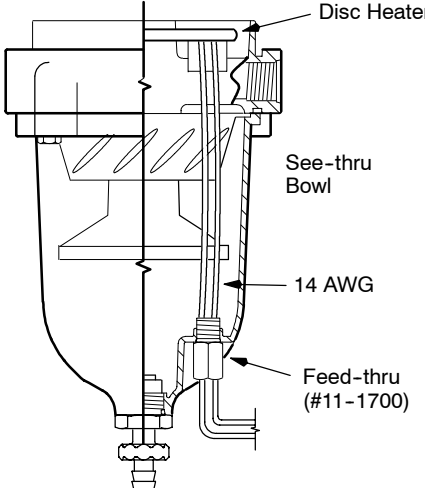

Turbine Series Heater & Water Probe Retrofit Kits

FOR A REPLACEMENT HEATER AND WATER PROBE THAT USES 'BULLET-TYPE' BOWL TERMINALS, OR TO ADD A HEATER AND WATER PROBE TO A UNIT THAT DOES NOT HAVE A HEATER FEED-THRU PORT IN THE BODY, USE THE SELECTION GUIDE BELOW.

900FG and 1000FG Series	
Kit Part No.	Description / Notes
RK11-1737	Retrofit Kit. Includes See-thru Bowl with two 'bullet-type' water probes and self-venting drain, Heater Feed-thru for bowl port, crimp terminals related seals and instructions. Order Heater below.
RK11-1767-01	12 vdc, 300 watt Heater Kit. Includes T-handle O-ring, Lid and bowl gasket. (Max. power draw 25 amps). Heater comes on at 50°F (± 8° F), off at 80°F (± 7° F)
RK11-1767-02	24 vdc, 300 watt Heater Kit. Includes T-handle O-ring, Lid and bowl gasket. (Max. power draw 13 amps). Heater comes on at 50°F (± 8° F), off at 80°F (± 7° F)

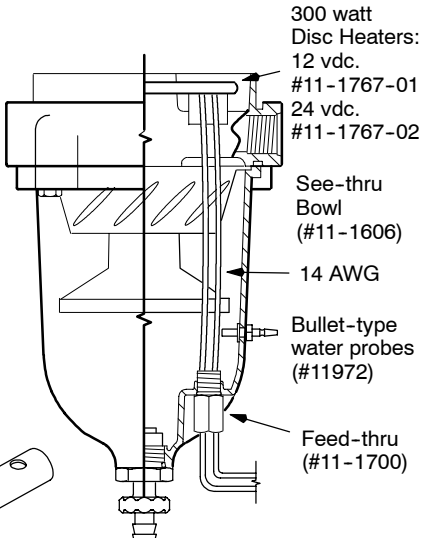

TOOLS 11-1708

Heater Feed-thru Wrench

Heater Electrical Relay Kits

The following relay kits may be necessary when installing Racor Heater Kits due to the power demand. Standard OE fuses, wiring and alternators may be unable to carry the load without overheating or potential shorting, creating a serious condition.

Caution: If you are uncertain if your electrical system can provide the additional power draw, consult your equipment dealer or a qualified electrician.

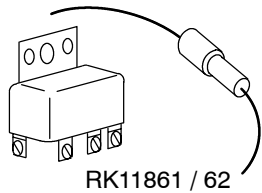
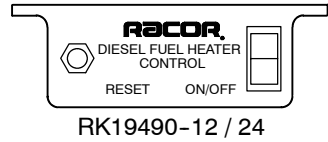
Kit Part No.	Description / Notes	
RK11861	Heater Relay Kit for 12 vdc. Remote mount. Handles up to 300 watts or 25 amps. Includes fuse and holder.	 <p>RK11861 / 62</p>  <p>RK19490-12 / 24</p>
RK11862	Heater Relay Kit for 24 vdc. Remote mount. Handles up to 360 watts or 15 amps. Includes fuse and holder	
RK19490-12	Heavy-Duty Relay Kit for 12 vdc. Under dash mount. Handles up to 600 watts or 50 amps.	
RK19490-24	Heavy-Duty Relay Kit for 24 vdc. Under dash mount. Handles up to 900 watts or 37 amps.	

Multiplex Filter/Separator Conversion Kits - Filter/Separators not included.

Racor conversion kits may be used to build a 'manifolded' unit in order to increase fuel flow or contaminant holding capacity. Valved models allow servicing of the fuel filter/water separator, even while the engine is running. Conversion kits are economical alternatives that permit the use of an existing unit. Additional units to complete the system may be purchased from your dealer as they are not included with these kits.

Note: Racor conversion kits are not intended for commercial marine use. See Section 2 for USCG accepted products.

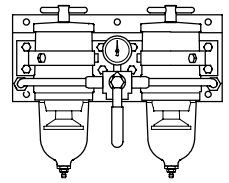
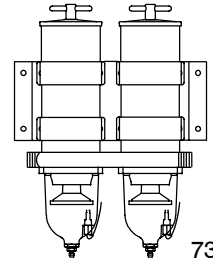
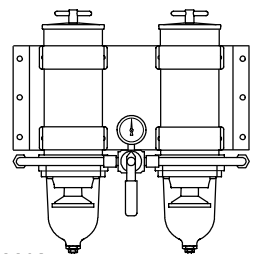
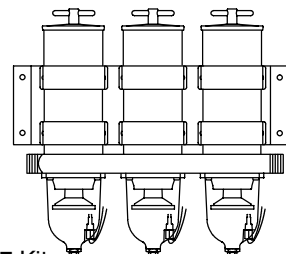
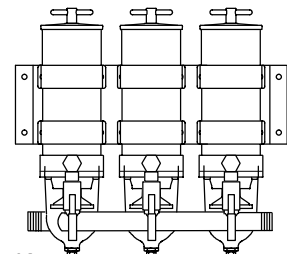
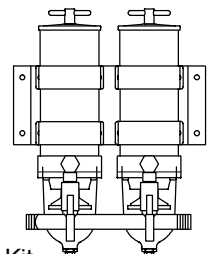
Kit Part No.	Description / Notes	
500FG Series -May only be used with 500 S/S unit featuring 9/16" - 18 ports.		
75500FGX Kit	Duplex Conversion Kit. Valve fuel ports: 3/4"SAE O-ring boss (SAEJ1926)	 <p>75500FGX Kit</p>
900FG and 1000FG Series -May only be used with units featuring 7/8" - 14 ports.		
73 Kit	Duplex Conversion Kit. Manifold tube inlet and outlet: 3/4"NPT (SAEJ476) 900 or 1000 Series	 <p>73 Kit</p>
75 Kit	Duplex Conversion Kit (with Four Ball Valves). Manifold tube inlet and outlet: 3/4"NPT (SAEJ476). 1000 only.	
75FGX Kit	Duplex Conversion Kit (with Selector Valve). Valve inlet and outlet: 7/8"SAE 37° male (SAEJ514). 1000 only.	
77 Kit	Triplex Conversion Kit. Manifold pipe inlet and outlet: 1"NPT (SAEJ476). 1000 only.	
79 Kit	Triplex Conversion Kit (with Six Ball Valves). Manifold Inlet and outlet: 1"NPT (SAEJ476). 1000 only.	
75FGX Kit		 <p>75FGX Kit</p>
77 Kit		 <p>77 Kit</p>
79 Kit		 <p>79 Kit</p>
75 Kit		 <p>75 Kit</p>

Racor On and Off Highway Fittings

Racor fittings are available in various materials, styles and sizes to fit every Racor filter/separator and most installation requirements. A helpful guide is found at the beginning of this book which outlines how part numbers are structured using the new Racor Part Numbering System.

Materials. Racor fittings are made of either brass (CA360 or CA345), plated steel (C12L14 with zinc di-chromate). When the part number is listed using the part numbering system, the second digit indicates the material, such as 91X= steel, 93X= stainless steel, and 95X= brass.

Styles. Racor products feature several porting styles to external plumbing however the most common are SAE J1926 Straight Thread O-ring and SAE J476 National Pipe Thread (see port chart at the beginning of this book). See the chart below for fitting torque values.

SAE J1926 and SAE J2244 Straight Thread O-ring. These designs utilize straight threads for holding power and an O-ring for superior sealing capability. Straight thread ports permit exact positioning of elbow fittings, provide a leak free joint, eliminate distortion and cracking of boss due to over tightening and are easier to maintain. The standard Parker O-ring material is compound No.N552-90, 90 durometer Buna-Nitrile (NBR). Apply a light coating of clean fuel or Parker Super O-lube to the O-ring prior to installation.

SAE J476 National Pipe Thread. Many Racor fuel ports feature the National Pipe Tapered for Fuels (NPTF -also known as Dryseal Pipe Thread) design for best sealing efficiency in smaller sizes of filters. The crests of the threads flatten upon tightening and allow the flanks to make contact thus sealing the joint. Use of a thread sealant, such as Parker's Unipar, is recommended to ensure a leak-proof seal. To avoid system contamination, do not apply sealant onto the first few threads.

SAE J1926 & J2244 Fitting Torque Specs			
SAE Dash Size	Thread Size (UN/UNF)	Assembly Torque	
		in. lbs.	ft. lbs.
3	3/8 - 24	155	13
4	7/16 - 20	205	17
5	1/2 - 20	250	21
6	9/16 - 18	300	25
8	3/4 - 16	540	45
10	7/8 - 14	-	85

SAE J476 National Pipe Thread	
Assembly Turns From Finger Tight (T.F.F.T.) Values for Steel and Brass Fittings	
Pipe Thread Size NPTF	T.F.F.T.
1/4 - 18	2 - 3
3/8 - 18	2 - 3
1/2 - 14	2 - 3
3/4 - 14	2 - 3
1 - 11 1/2	1.5 - 2.5

SAE / JIC 37° Male Flare Torque Specs			
SAE Dash Size	Thread Size (UN/UNF)	Assembly Torque	
		in. lbs.	T.F.F.T.
4	7/16 - 20	-	-
6	9/16 - 18	-	-
8	3/4 - 16	550 ± 50	1
10	7/8 - 14	650 ± 50	1

Port Plug Kits

Part No.	Used for	Material	Thread	Qty/Kit
RK30817	Fuel Port	Metal	1/4"-18 NPT	2
22231	Fuel Port	Metal	3/8"-18 NPT	2
RK10110	Vent Plug	Metal	3/8"-24 SAE	1
RK20022	Fuel / Wtr.Probe	Metal	1/2"-20 SAE	2
RK11-1679	Fuel / Heater	Plastic	9/16"-18 SAE	1
22351	Fuel Port	Plastic	3/4"-16 SAE	2
11911	Fuel Port	Metal	7/8"-14 SAE	1
RK20618	Fuel / Vent	Metal	14M X 1.5 Metric	2
22509	Fuel Port	Metal	16M X 1.5 Metric	2

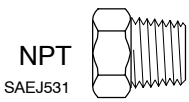

NPT
SAEJ531



SAE
SAEJ514

Check Valve Fittings

Part No.	Use with:	Thread 1	Thread 2	Qty.
RK10034	122	Fits inside selected inlet port Not for NPT port heads (not shown).		1
RK31610	100 / 200 Series	1/4"NPT	1/4"NPT	1
RK30770	300 / 600 Series	3/8"NPT	3/8"NPT	1

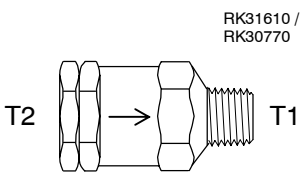

RK31610 /
RK30770

On and Off Highway Fittings

Fittings

100, 200, 300, 400 & 600 Series Fittings -Package quantity is 10 pcs.

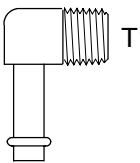
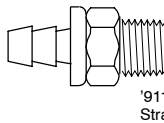
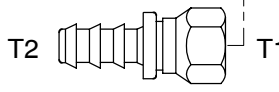
Part No.	Old Part No.	Thread 1 (SAEJ476)	Hose 2 (or thread)	Tube or Hose Size Number	
953-N4-H5	No change	1/4"-18	5/16"	5	 <p>T1 '913' NPT Beaded Elbow</p>
913-N4-H6	953-N4-H6	1/4"-18	3/8"	6	
913-N6-H6	953-N6-H6	3/8"-18	3/8"	6	
951-N4-H4	RK30815	1/4"-18	1/4"	4	 <p>T1 '911' NPT Barbed Straight</p>
951-N4-H5	RK21132	1/4"-18	5/16"	5	
911-N4-H6	951-N4-H6	1/4"-18	3/8"	6	
951-N6-H4	New	3/8"-18	1/4"	4	
951-N6-H5	No change	3/8"-18	5/16"	5	
911-N6-H6	951-N6-H6	3/8"-18	3/8"	6	
911-N6-H8	951-N6-H8	3/8"-18	1/2"	8	
951-N6-J6	0103-6-6B	3/8"-18	9/16"-18UNF	6	
951-N6-J8	0103-6-8B	3/8"-18	3/4"-16UNF	8	
955-W6-H6	30682-6-6B	9/16"-18UNF	3/8"	6	 <p>T2 T1 '955' SAE Swivel</p>
955-W8-H8	30682-8-8B	3/4"-16UNF	1/2"	8	

91X fittings are made of steel, and 95X fittings are made of brass. Plated steel fittings are recommended for applications exposed to salt spray.

500FG (MAX) Series Fittings -Package quantity is 10 pcs.

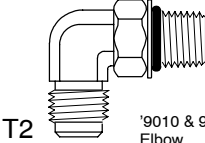
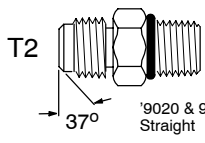
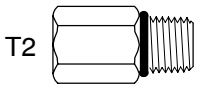
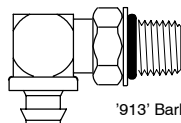
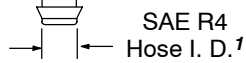
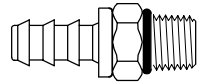
Fitting Part No.	Old Part No.	Thread 1 (SAEJ1926)	Thread 2 (or Hose I.D.)	Tube or Hose Size Number		
9010-6-4	No change	9/16"-18	7/16"-20	4	 <p>T2 T1 '9010 & 913' SAE Elbow</p>	
9010-6-6	No change	9/16"-18	9/16"-18	6		
913-O8-J6	New	3/4"-16	9/16"-18	6		
913-O8-J8	9010-8-8	3/4"-16	3/4"-16	8		
913-O8-J10	9010-8-10	3/4"-16	7/8"-14	10		
9020-6-4	No change	9/16"-18	7/16"-20	4	 <p>T2 T1 '9020 & 911' SAE Straight 37°</p>	
9020-6-6	No change	9/16"-18	9/16"-18	6		
911-O8-J6	New	3/4"-16	9/16"-18	6		
911-O8-J8	9020-8-8	3/4"-16	3/4"-16	8		
911-O8-J10	9020-8-10	3/4"-16	7/8"-14	10		
911-O4-F4	9040-4-4	7/16"-20	1/4"-18	4	 <p>T2 T1 '9040 & 911' NPT Female</p>	
9040-6-4	No change	9/16"-18	1/4"-18	4		
9040-6-6	No change	9/16"-18	3/8"-18	6		
911-O8-F4	New	3/4"-16	1/4"-18	4		
911-O8-F6	New	3/4"-16	3/8"-18	6		
911-O8-F8	9040-8-8	3/4"-16	1/2"-14	8		
913-O6-H5	9010HF-6-5/6	9/16"-18	5/16"	5		 <p>T1 '913' Barbed Elbow</p>
913-O6-H6	9010HF-6-5/6	9/16"-18	3/8"	6		
913-O8-H5	New	3/4"-16	5/16"	5		
913-O8-H6	New	3/4"-16	3/8"	6		
913-O8-H8 ²	New	3/4"-16	1/2"	8		
913-O8-H10 ²	New	3/4"-16	5/8"	10		
911-O6-H5/6	9020HF-6-5/6	9/16"-18	5/16-3/8"	5 - 6	 <p>SAE R4 Hose I. D.¹</p>	
911-O8-H6 ²	New	3/4"-16	3/8"	6		
911-O8-H8 ²	New	3/4"-16	1/2"	8		
911-O8-H10 ²	New	3/4"-16	5/8"	10		
						 <p>T1 '911' Barbed Straight</p>

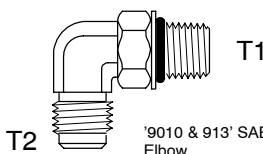
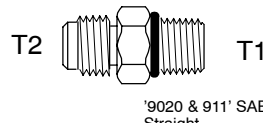
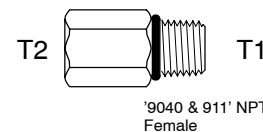
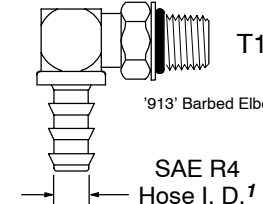
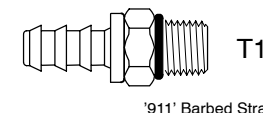

¹ Illustration may not represent fitting contour exactly. Parker 800 Series (SAE R4) Push-Lok low pressure hose recommended. Source from Parker Hannifin Corporation, Hose Products Division. For your local distributor call: (216) 943-5700, E.S.T. ² Hose bead fitting, requires hose clamp.

900FG (MAX) & 1000FG (MAX) Series Fittings -Package quantity is 10 pcs.

SAE Elbow Fitting Part No.	Old Part No.	Thread 1 (SAEJ1926)	Thread 2 (or Hose I.D.)	Tube or Hose Size Number	
9010-10-8	No change	7/8"-14	3/4"-16	8	 <p>'9010 & 913' SAE Elbow</p>
9010-10-10	No change	7/8"-14	7/8"-14	10	
SAE Strt. Fitting					
9020-10-6	No change	7/8"-14	9/16"-18	6	 <p>'9020 & 911' SAE Straight</p>
9020-10-8	No change	7/8"-14	3/4"-16	8	
9020-10-10	No change	7/8"-14	7/8"-14	10	
SAE to NPTF					
911-O10-F4	9040-10-4	7/8"-14	1/4"-18	4	 <p>'9040 & 911' NPT Female</p>
911-O10-F6	9040-10-6	7/8"-14	3/8"-18	6	
911-O10-F8	9040-10-8	7/8"-14	1/2"-14	8	
911-O10-F12	9040-10-12	7/8"-14	3/4"-14	12	
SAE to Hose					
913-O10-H5	9010HF-10-6	7/8"-14	5/16"	5	 <p>'913' Barbed Elbow</p> <p>SAE R4 Hose I. D.¹</p>
913-O10-H6	9010HF-10-8	7/8"-14	3/8"	6	
913-O10-H8	9010HF-10-10	7/8"-14	1/2"	8	
913-O10-H10	9010HF-10-12	7/8"-14	5/8"	10	
913-O10-H12	New	7/8"-14	3/4"	12	
SAE to Hose					
911-O10-H5	9020HF-10-6	7/8"-14	5/16"	5	 <p>'911' Barbed Straight</p>
911-O10-H6	9020HF-10-8	7/8"-14	3/8"	6	
911-O10-H8	9020HF-10-10	7/8"-14	1/2"	8	
911-O10-H10	9020HF-10-12	7/8"-14	5/8"	10	
911-O10-H12	New	7/8"-14	3/4"	12	

¹ Illustration may not represent fitting contour exactly. Parker 800 Series (SAE R4) Push-Lok low pressure hose recommended. Source from Parker Hannifin Corporation, Hose Products Division. For your local distributor call: (216) 943-5700, E.S.T.

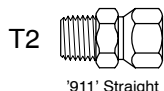
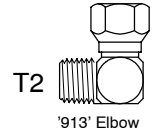
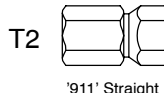
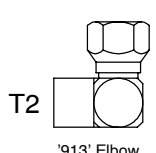
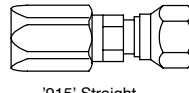
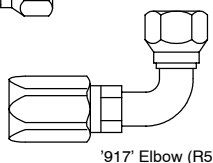
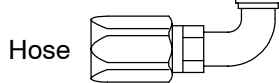
75/900FGX (MAX) & 75/1000FGX (MAX) Series Fittings -Package quantity is 1 each.

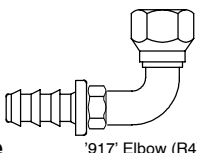
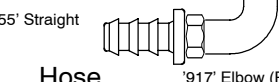
Fitting Part No.	Adapter Description	Thread 1	Thread 2	
911-W10-N6	Straight Swivel, SAE X NPTM	7/8"-14	3/8"-18	 <p>'911' Straight</p>  <p>'913' Elbow</p>
911-W10-N8	Straight Swivel, SAE X NPTM	7/8"-14	1/2"-14	
911-W10-N12	Straight Swivel, SAE X NPTM	7/8"-14	3/4"-14	
911-W10-B8	Straight Swivel, SAE X BSPT	7/8"-14	1/2"-14	
913-W10-N8	Elbow Swivel, SAE X NPTM	7/8"-14	1/2"-14	 <p>'911' Straight</p>  <p>'913' Elbow</p>
911-W10-F8	Straight Swivel, SAE X NPTF	7/8"-14	1/2"-14	
911-W10-F12	Straight Swivel, SAE X NPTF	7/8"-14	3/4"-14	
913-W10-F8	Elbow Swivel, SAE X NPTF	7/8"-14	1/2"-14	 <p>'915' Straight</p>  <p>'917' Elbow (R5)</p>
Fitting Part No. Adapter Description Thread 1 Hose I.D. (SAE R5)				
915-W10-R8	Straight Swivel, SAE X Hose	7/8"-14	13/32" (#8)	 <p>Hose</p>
915-W10-R10	Straight Swivel, SAE X Hose	7/8"-14	1/2" (#10)	
915-W10-R12	Straight Swivel, SAE X Hose	7/8"-14	5/8" (#12)	
917-W10-R8	Elbow Swivel, SAE X Hose	7/8"-14	13/32" (#8)	 <p>'955' Straight</p>  <p>'917' Elbow (R4)</p>
917-W10-R10	Elbow Swivel, SAE X Hose	7/8"-14	1/2" (#10)	
917-W10-R12	Elbow Swivel, SAE X Hose	7/8"-14	5/8" (#12)	
Fitting Part No. Adapter Description Thread 1 Hose I.D. (SAE R4)				
955-W10-H8	Straight Swivel, SAE X Hose	7/8"-14	1/2" (#8)	 <p>Hose</p>
955-W10-H10	Straight Swivel, SAE X Hose	7/8"-14	5/8" (#10)	
917-W10-H10	Elbow Swivel, SAE X Hose	7/8"-14	5/8" (#10)	

Racor Products

Section 2 Marine Products



- Selection
- Gasoline Series
- 025 & 32013 32020
- 120/320/660/3120
- Diesel Spin On
- 110A
- 120RMAM
- 200 Series
- 400 Series
- Turbine Series
- 500MA
- 900MA
- 1000MA
- 73/1000MA
- 75/500MAX
- 75/900MAX
- 75/1000MAX
- 77/1000MA
- 79/1000MAV
- Fuel/Air Separators

- Drinking Water Filters
- Air Filtration
- Accessories

○ ? Help & General Information

SELECTION - SECTION 2

DIESEL, KEROSENE AND GASOLINE FUEL FILTERS:

Note: Most products in this section are Underwriters Laboratories Listed for Marine use and many are U.S.C.G. Accepted or meet A.S.T.M. Specification F-1201. Documentation or certification is available upon request.

1. Find the **application**: Diesel #2, Kerosene or Gasoline.
2. Find the **installation**. Will the unit be installed on the suction (vacuum) or pressure side of the fuel pump? Racor units are most efficient when installed on the suction side of the fuel system. If the filter is a replaceable engine spin-on type, go directly to the 320 Engine Spin-on Series.
3. Find the **total fuel flow rate**. This is the total flow that will pass through the filter. You may obtain this information from your engine or equipment manufacturer or your Racor dealer. Use this information to select a Racor filter that has a greater flow rating than your equipment's total fuel flow rate.

If this information is not available use the following formula for estimating.

Diesel or kerosene fuel systems:

Gallons per Hour is Engine Horsepower (maximum) multiplied by 18% or $GPH = HP \times 0.18$

Gasoline fuel systems (carbureted):

Gallons per Hour is Engine Horsepower (maximum) multiplied by 10% or $GPH = HP \times 0.1$

Gasoline fuel systems (fuel injected):

Use a straight 40 GPH figure. Smaller outboards will use a 25 GPH figure.

4. What other conditions apply?

Water contamination. A water detection package should be added to inform the operator of water build-up and necessary servicing. Water detection packages are available for use with all models in diesel fuel applications, only.

Does the engine need to run continuously, not allowing a shut-down for needed servicing, such as a generator? If so, see 'Turbine' models with the '75, or 79' prefix in the part number.

What type of filter element best suits your vessel? The 'Turbine' series have element cartridges that are serviced from the top and all other units in this section have a removeable spin-on type canister that is serviced from the bottom.

A convenient feature may be a head mounted, hand operated priming pump. See models 215MAM, 230MAM, and 245RMAM as well as 445MAM, 460MAM, 490MAM and 4120MAM models.

5. With the above information, review the models suggested that best fit your installation. Most of the Model Groups have additional information to help in identifying the exact model for your needs. Call your Racor distributor or Racor customer service if you need additional assistance at: (800) 344-3286, or e-mail us from our website at www.parker.com/racor.

HYDRAULIC FILTERS, LIQUID TRANSFER SYSTEMS, FUEL / AIR SEPARATORS and DRINKING WATER FILTERS:

1. Go directly to those Sections for specific selection information.
-

Selection Information

Power Boats with Inboard Gasoline Engines:

1. Power boats with inboard gasoline engines must use units equipped with metal bowls.
2. Stock carbureted engines can use all units.
Fuel-injected or high performance engines (or severe service applications) should use units with a flow rate between 40 to 120 gallons per hour (GPH).
Consult the engine manufacturer for the exact fuel filter flow rate.
3. For boats where a fuel filter/water separator is already installed:
This is generally a MerCruiser or OMC style filter (fuel ports on top of filter head).
Use the B32020MAM (MerCruiser) or B32021MAM (OMC).
If there are no filters already installed, specify the 120R-RAC-01, 320R-RAC, or 660R-RAC units. For high-performance boats the 3120R-RAC-32 is recommended.

IMPORTANT: All units must be installed on the suction (vacuum) side of the fuel or transfer pump.

Power Boats with Outboard Gasoline Engines:

1. Power boats with outboard gasoline engines can use either see-thru blue bowls or metal bowls.
2. Stock carbureted engines can use all units.
High performance engines (or severe service applications) should use units with a flow rate between 40 to 90 gallons per hour (GPH).
3. For boats where a fuel filter/water separator is already installed:
This is generally a Quicksilver or OMC style filter (fuel ports on top of filter head).
Use the B32013 (Quicksilver) or B32014 (OMC).
If there are no filters already installed, specify the 120R-RAC-01, 320RRAC, or 660RRAC units. For high-performance boats the 3120R-RAC-32 is recommended.

IMPORTANT: All units must be installed on the suction (vacuum) side of the fuel or transfer pump.

Gasoline Powered Boats-Continuous Operation:

1. For engine(s) that must run continuous and/or cannot be shut-down for servicing, specify only MAVM or MAXM units (with metal bowls) found under 'Fuel Filter/Water Separators, Turbine Series', which follows this series.
All other boats that are routinely serviced daily may specify any series model with a metal bowl.

SELECTION:

1. Along with the information you obtained in SECTION 2, SELECTION (page 94), consider the following: Are there any space limitations in the available location? The location should provide adequate space for removing the element, draining off contaminants from the bowl.
2. What filtration rating is needed? Gasoline spin-on filters are standard with 10 micron media. Turbine models can be ordered with 2, 10 or 30 micron media.

Using this information, select a unit from the next page, or check the models which follow to find just the right unit for your application.

For additional information, call your Racor dealer or call Racor customer service: (800) 344-3286, 6 AM to 5 PM, Pacific Time, or e-mail us from our website, www.parker/racor.

Model Illustrations

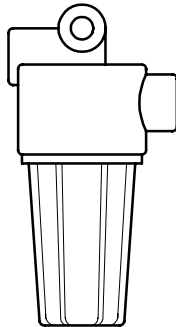

025-RAC-01,
025-RAC-02



025-RAC-05

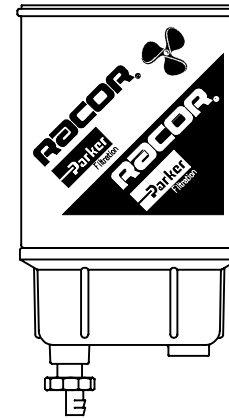

B32013,
B32014,
B32020MAM,
B32021MAM

Special Notes

- 025-RAC-01 and 025-RAC-02 configurations are for outboard engine applications **only**.
- B32013 & B32014 model configurations with blue, see-thru bowls, are for outboard engine applications **only**.
- MAM metal bowl units are approved for gasoline service. UL Recognized.
- For additional information and availability, contact customer service: (800) 344-3286, 6 AM to 5 PM, Pacific Time, or e-mail us from our website, www.parker.com/racor.



Specifications

BASIC MODELS		025-RAC-01, 025-RAC-02	025-RAC-05	B32013, B32014	B32020MAM, B32021MAM
Maximum Flow Rate	GPH LPH	25 95	25 95	60 227	60 227
Filter Element Part Numbers		S2501/ S2502	N/A	S3213/ S3214	S3220UL S3220UL
Filter Element Center Threads		N/A	N/A	11/16-16	11/16-16
Head Port Size		N/A	N/A	1-12	1-12
		1/4-18NPTF(2)	N/A	N/A	N/A
Height	in. mm	4.31 109	4.75 121	6.75 171	6.75 171
Width	in. mm	2.25 57	2.30 Dia. 58 Dia.	3.75 Dia. 95 Dia.	3.75 Dia. 95 Dia.
Depth	in. mm	2.10 53	2.30 Dia. 58 Dia.	3.75 Dia. 95 Dia.	3.75 Dia. 95 Dia.
Weight (dry)	Lbs. kgs.	0.3 0.14	0.27 0.12	1.2 0.54	1.6 0.73
Clean Pressure Drop	PSI kPa	0.26 / 0.35 1.8 / 2.4	2.5 17.2	0.61 ¹ 4.23 ¹	0.61 4.23
Max Pressure	PSI	100	30		
Element Removal Underbowl Clearance	in. mm	1 25.4	N/A	1 25.4	1 25.4
Operating Temperature		Temp. ²	-40° / +255° F	/	-40° / +121° C

¹ Acquired using 320R-RAC mounting head.

² 025-RAC Series: Operating Temperature: -10° / +180° F / -23° / +82° C

SPECIFICATIONS are found on the introduction page.

How to Order -The example below illustrates how the part numbers are constructed.

025-RAC	-02
25 GPH (optimum flow rate) Cast aluminum mounting head with 1/4"NPT inlet and outlet fuel ports. Features one hole for mounting with up to a 1/4" diameter capscrew. Reusable, spin-on see-thru collection bowl.	Filter Media: '-01' 250 micron plastic fuel straining element (#S2501 Not for water removal). '-02' 10 micron Aquabloc™ filter element (#S2502).
WARNING! FOR OUTBOARD ENGINES, PERSONAL WATER CRAFT AND OTHER APPLICATIONS. DO NOT USE THIS FILTER WITH INBOARD ENGINES OR STERN DRIVE BOATS - USE RACOR U.L. LISTED MARINE FILTERS. SEE INDEX.	

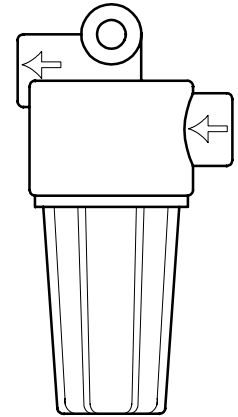

025-RAC-01/02

Replacement Service Parts -Elements include replacement bowl O-ring.
 Note: Replace filter annually or at the first indication of power loss, whichever comes first. Always keep an extra filter element on hand.

025-RAC-01 use S2501 250 micron plastic fuel straining element. 025-RAC-02 use S2502 10 micron Aquabloc™ filter element. 31391 Replacement See-thru Bowl 31185 Replacement Bowl O-ring only (for both models).

Performance Graphs -Results are from controlled laboratory tests. Field results may vary.

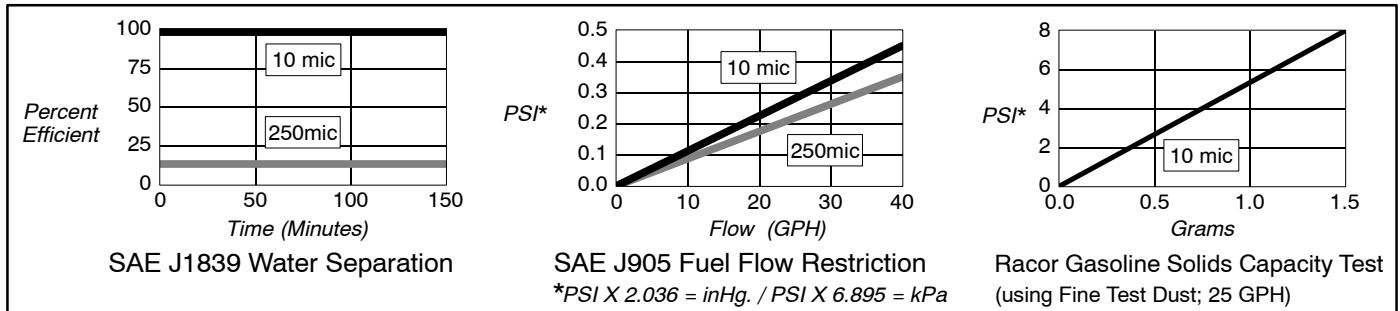

025-RAC-05	Features:
In-line Filter, 25 GPH. 5/16" Hose beads on inlet and outlet fuel ports with 10 micron filtering media. Secure hoses with hose clamps (not provided).	<ul style="list-style-type: none"> • All Stainless Steel construction • Black 'E' coating for corrosion protection • Only 2.5 PSI restriction @ 25 GPH. • Can withstand up to 30 PSI.

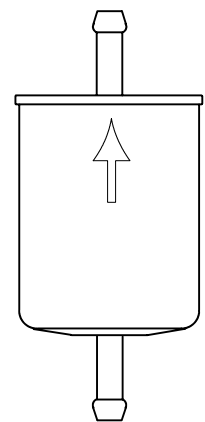

025-RAC-05

Replacement Information

This filter may be used in all suction (vacuum) side fuel system installations or in pressure side installations up to 30 PSI.
 The filter should be replaced annually or if there is a noticeable loss of power, whichever comes first. Always carry a spare filter onboard as one tank full of contaminated fuel can easily plug a filter.

SPECIFICATIONS are found on the introduction page.



Underwriter's Laboratories
Recognized Component

How to Order - The blocks below detail the features of these units.

B32013	B32014	B32020MAM	B32021MAM
60 GPH. Fits 11/16"-16 Quicksilver heads. S3213 10 micron Aquabloc™ media & blue see-thru collection bowl. For outboard engine applications only.	60 GPH. Fits 1"-12 OMC heads. S3214 10 micron Aquabloc™ media & blue see-thru collection bowl. For outboard engine applications only.	60 GPH. Fits 11/16"-16 Mercuriser mounting heads. S3220 10 micron Aquabloc™ media with metal collection bowl and 3/8" drain plug. <i>UL Recognized Component</i> For inboard or outboard engine applications.	60 GPH. Fits 1"-12 OMC mounting heads. S3221 10 micron Aquabloc™ media with metal collection bowl and 3/8" drain plug. <i>UL Recognized Component</i> For inboard or outboard engine applications.

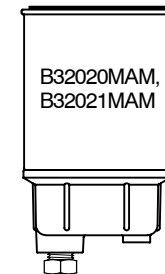
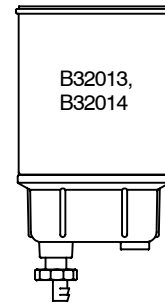

2

Quick Cross Reference Chart - for Racor units with bowls

Note: For replacement filter elements only, see item 1 in parts list below.

<u>Aquapower</u>	<u>RACOR</u>	<u>PCM</u>	<u>RACOR</u>
6001	B32013	R080020	S3228UL (without bowl)
6031	B32020	<u>Sierra</u>	
6040	B32014 / B32021	18-7845	B32013
		1807850	B32020MAM
<u>Baldwin</u>		<u>Suzuki US</u>	
BF791	B32013 / B32020MAM	99105-2004	S3227 (without bowl)
<u>Fram</u>		<u>Volvo</u>	
PS3808	B32013 / B32020MAM	855686-0 / -2	B32020MAM
<u>Quicksilver (Mercury Marine)</u>		<u>Wix</u>	
35-807172 / 35-60494-1	B32020MAM	33225	B32013 / B32020MAM
35-805269-1 / 35-807172 / 35-805269-1	B32013	<u>Yamaha</u>	
<u>OMC</u>		ABA-FUEL-FLTR	B32013
502905	B32014	MAR-23452-00-00	S3220UL (without bowl)
174144	B32021MAM		

Parts List

Item/Part No.	Description	Case Qty.
1 20707	O-ring / gasket pack: all units	1
2 S3213	'B32013' Element -10 micron	12
S3214	'B32014' Element -10 micron	12
S3220UL	'B32020' Element -10 micron	12
S3221UL	'B32021' Element -10 micron	12
3 RK30747	See-thru Blue Bowl (shown)	1
RK30473-02	Metal Bowl & NPT plug, white powder 'paint' coating (MAM)	1
4 RK30476	Plastic Drain Knob	1
RK22099	Drain Gasket	
918-N6	Metal Plug, 3/8" NPT (MAM)	1

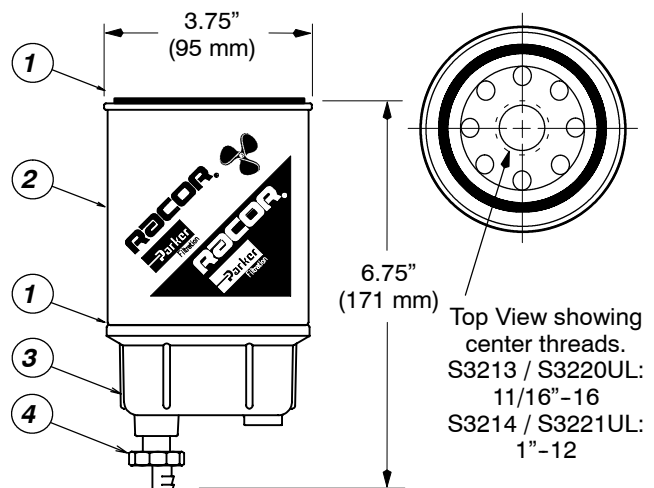

Model Illustrations

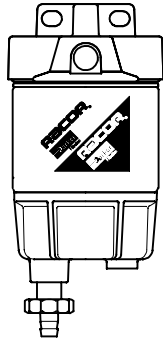

120R-RAC-01



320R-RAC-01,
320R-RAC-02

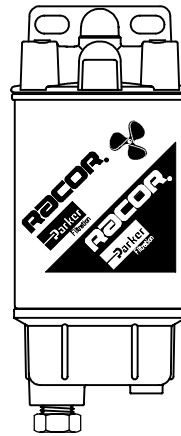

660R-RAC-01,
660R-RAC-02

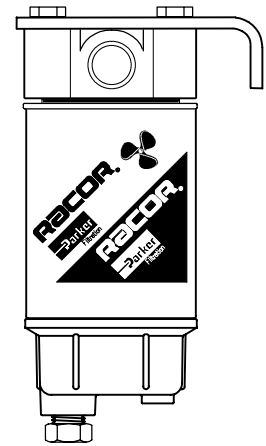

3120R-RAC-32
(side view)

Special Notes

1. 120R-RAC-01, 320R-RAC-01, and 660R-RAC-01 configurations with blue, see-thru bowls, are for outboard engine applications **only**.
3. MAM metal bowl units are approved for gasoline service. UL Recognized.
4. 320R-RAC-02, 660R-RAC-02 and 3120R-RAC-32 configurations are approved for inboard engine or outboard engine gasoline service. UL Listed.
5. For additional information and availability, contact customer service: (800) 344-3286, 6 AM to 5 PM, Pacific Time, or e-mail us from our website, www.parker.com/racor.



Specifications

BASIC MODELS		120R-RAC-01	320R-RAC-01 320R-RAC-02	660R-RAC-01 660R-RAC-02	3120R-RAC-32
Maximum Flow Rate	GPH LPH	30 114	60 227	90 340	120 454
Filter Element Part Numbers		S3240	S3227/ S3228UL	S3232/ S3232UL	S3232UL
Center Threads		M18 X 1.5	1-14	1-14	1-14
Head Port Size		1/4-18NPTF(4)	1/4-18NPTF(3)	3/8-18NPTF(4)	1/2-14NPTF(2)
Height	in. mm	6.5 166	9.38 238	11.00 280	10.38 264
Width	in. mm	3.2 81	4 102	4.2 106	4 102
Depth	in. mm	3.2 81	4 102	4.5 114	5 127
Weight (dry)	Lbs. kgs.	1.1 0.5	2 0.90	3 1.4	2 0.90
Clean Pressure Drop	PSI kPa	0.15 1.03	0.61 4.23	0.61 4.23	0.15 1.03
Max Pressure	PSI	7			
Element Removal Underbowl Clearance	in. mm	1 25.4	1 25.4	1 25.4	1 25.4
Operating Temperature		-40° / +255° F / -40° / +124° C			Temp. ¹

¹ 3120R-RAC-32 Operating Temperature: -10° / +180° F / -23° / +82° C

SPECIFICATIONS are found on the introduction page.

How to Order

120R-RAC-01

Fuel Filter / Water Separator Assembly. This unit is designed for smaller gasoline applications and may handle fuel flows up to 30 gallons per hour (GPH). The assembly has an anodized base plating and is then coated with a durable electrostatically applied powder coating for superior corrosion resistance. The spin-on filter design is simple to replace and the reusable plastic contaminant collection bowl features a self-venting drain valve for removing unwanted water.

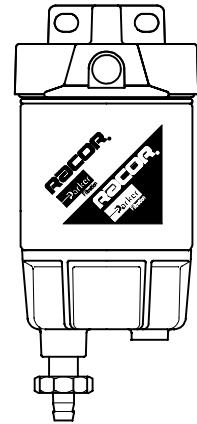

120R-RAC-01

Replacement Service Element -12 per case, element seals included.

Element Part No.	Micron Rating
S3240	10

Performance Graphs

-These results are from controlled laboratory tests. Field results may vary.

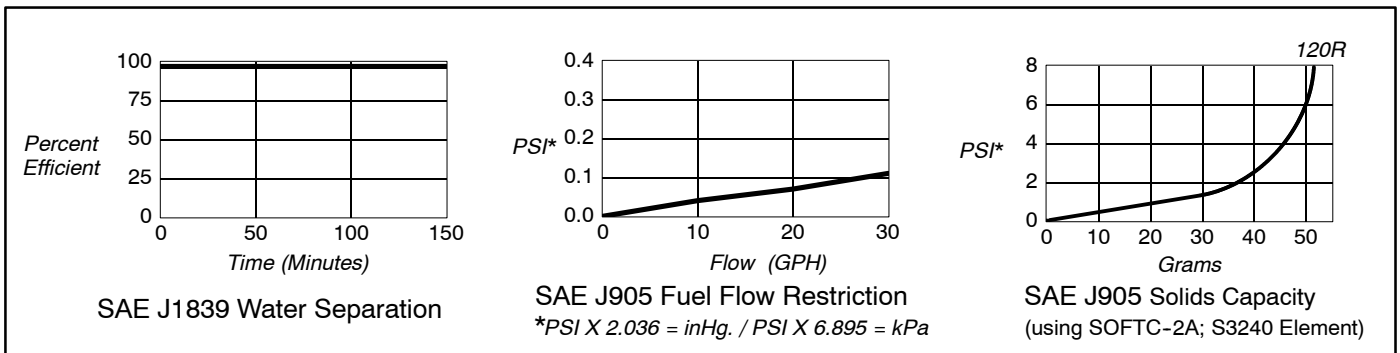

Mounting Pattern / Parts List

-The circled number corresponds to the item number shown below.

(Not to scale)

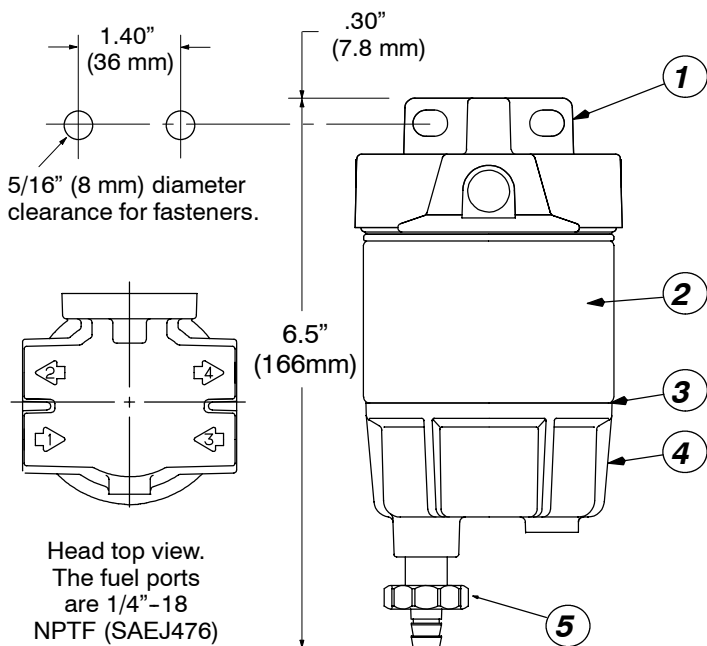

Item/Part No.	Description	Case Qty.	
1	RK10214-01	Head, 1/4" NPTF Ports	1
	918-N4	1/4" steel port plugs	1
2	S3240	Service Element, 10 micron	12
3	RK10012	Bowl O-ring	1
4	RK10222	See-thru Bowl / Drain	1
5	RK30476	Drain Valve Assembly	1
	10223	Installation Instructions	

SPECIFICATIONS are found on the introduction page.

How to Order -The example below illustrates how the part numbers are constructed.

320R-RAC	-01
<p><u>Basic Model</u> 60 GPH. Three port head with 1/4" NPT tapered pipe threads, anodized base plating, and white powder 'paint' coating.</p>	<p><u>Bowl Configuration:</u> '-01' for See-thru bowl (outboard engine use only) '-02' for Metal bowl (inboard or outboard engine use). UL MARINE LISTED</p>

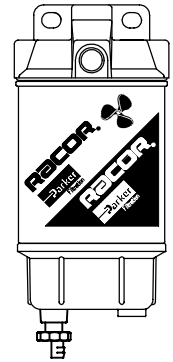

320R-RAC-01

Replacement Service Elements

SERVICE ELEMENT INCLUDES REPLACEMENT TOP AND BOTTOM SEAL.

320R-RAC-01 use **S3227**, 10 micron.

320R-RAC-02 use **S3228UL**, 10 micron. UL Recognized element.



320R-RAC-02



Mounting Hole Pattern / Parts List

Item/Part No.	Description	Case Qty.
1	RK20180 Mounting Head	1
2.	20707 O-ring / gasket pack: all units	1
3.	S3227 '01' Element (10 micron)	12
	S3228UL '02' Element (10 micron)	12
4	RK30747 '01' See-thru Blue Bowl (shown)	1
	RK30473-02 '02' Metal Bowl and NPT plug,	
	White powder 'paint' coating	1
5	RK30476 '01' Drain Knob	1
	918-N6 Steel port Plug, 3/8" NPT	1
	22237 Installation Instructions	

Head top view. Fuel ports are: 1/4"-18 NPT (SAEJ476)

Performance Graphs

These results are from controlled laboratory tests. Field results may vary.

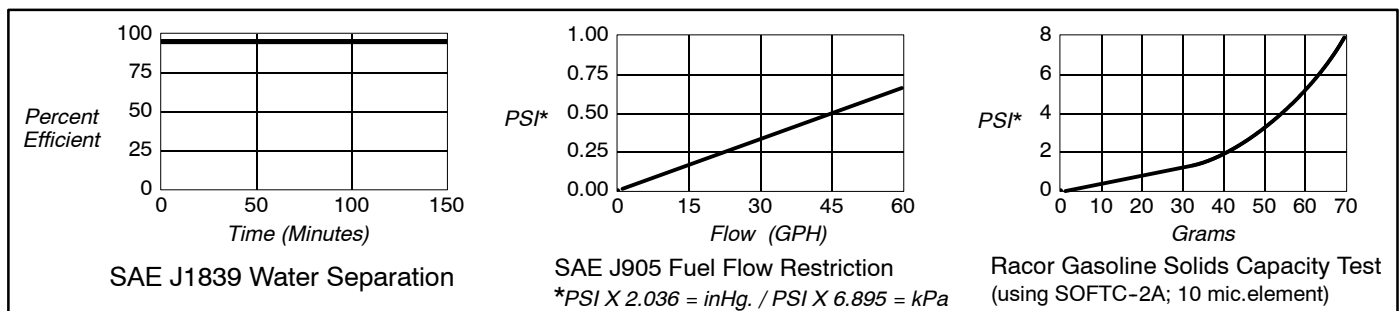

SPECIFICATIONS are found on the introduction page.

How to Order -The example below illustrates how the part numbers are constructed.

660R-RAC	-01
<p><u>Basic Model</u> 90 GPH. Four port head with 3/8" NPT tapered pipe threads, anodized base plating, and white powder 'paint' coating.</p>	<p><u>Bowl Configuration:</u> '-01' for See-thru bowl (outboard engine use only) '-02' for Metal bowl (inboard or outboard engine use). UL MARINE LISTED</p>

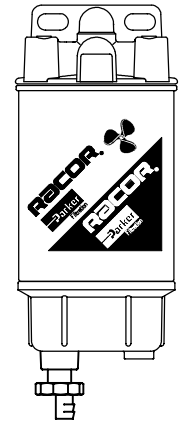

660R-RAC-01

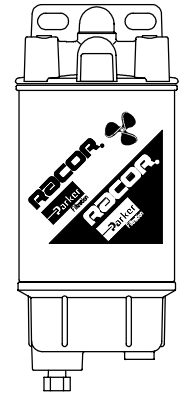

660R-RAC-02

Replacement Service Elements

SERVICE ELEMENT INCLUDES REPLACEMENT TOP AND BOTTOM SEAL.

660R-RAC-01 use **S3232**, 10 micron.

660R-RAC-02 use **S3232UL**, 10 micron. UL Recognized element.



Mounting Hole Pattern / Parts List

Item/Part No.	Description	Case Qty.
1 RK21411	White Mounting Head	1
2 20707	O-ring / gasket pack: all units	1
3. S3232	'01' Service Element	12
S3232UL	'02' Service Element	12
4 RK30747	'01' See-thru Blue Bowl (shown)	1
RK30473-02	'02' Metal Bowl & NPT plug	1
	White powder 'paint' coating	1
5 RK30476	'01' Drain Knob (shown)	1
918-N6	Steel port plug, 3/8" NPT	1
21385	Installation Instructions	

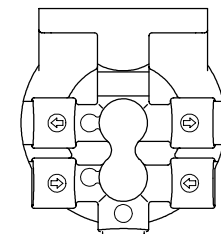
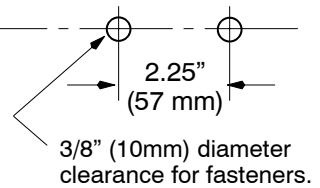
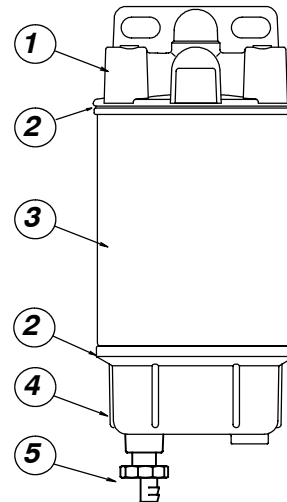

Head top view. Fuel ports are: 3/8"-18NPTF (SAEJ476)

Performance Graphs

These results are from controlled laboratory tests. Field results may vary.

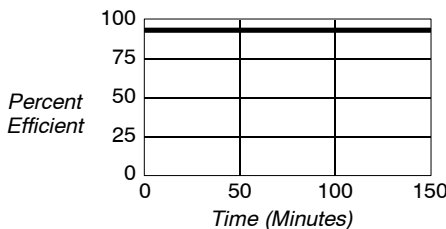

SAE J1839 Water Separation

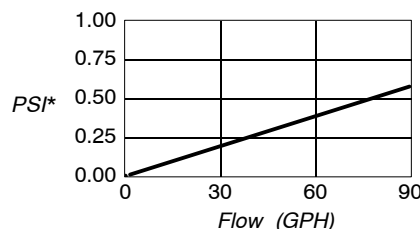

SAE J905 Fuel Flow Restriction

*PSI X 2.036 = inHg. / PSI X 6.895 = kPa

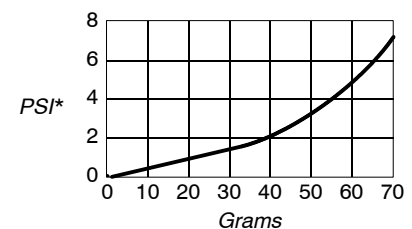

Racor Gasoline Solids Capacity Test (using SOFTC-2A; 10 mic. element)

SPECIFICATIONS are found on the introduction page.

How to Order

3120R-RAC-32

Fuel Filter / Water Separator Assembly. This unit is designed for high-performance gasoline applications and may handle fuel flows up to 120 gallons per hour (GPH) or 2 gallons per minute. The assembly is coated with a durable electrostatically applied powder coating that resists corrosion. The spin-on filter design is simple to replace and the reusable metal contaminant collection bowl features a plug for removing unwanted water.

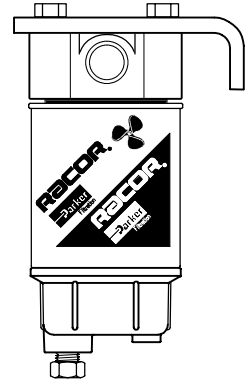

3120R-RAC-32

Replacement Service Element -12 per case, element seals included.

Element Part No.	Micron Rating	Element Height	Overall Height
S3232UL	10	5-1/2"	10-3/8"



Performance Graphs

-These results are from controlled laboratory tests. Field results may vary.

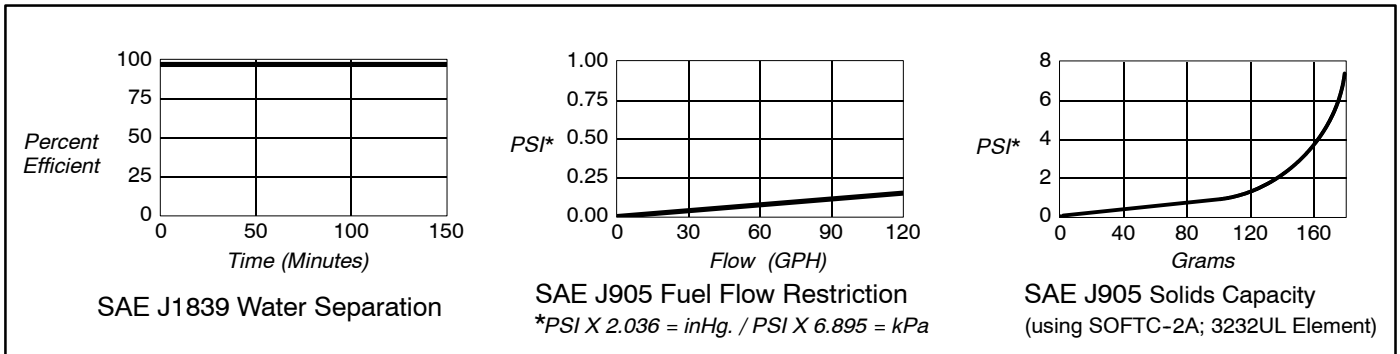

Mounting Pattern / Parts List

-The circled number corresponds to the item number shown below.

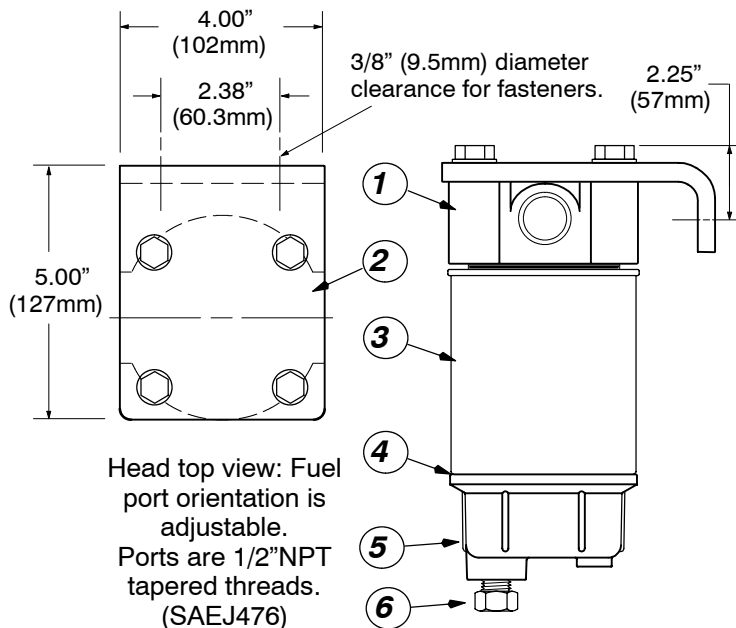

Item/Part No.	Description	Case Qty.
1 RK30308-01	Filter Head with 1/2" NPT fuel ports and white powder 'paint' coating.	1
2 RK30288-01	Mounting Bracket with white powder 'paint' coating & fasteners.	1
3 S3232UL	Replacement Spin-on Element, 120 GPH, 10 micron.	12
4 RK30076	Bowl O-ring	20
5 RK30473-02	Replacement Metal Bowl. White powder 'paint' coating.	1
6 918-N6	Steel Plug, 3/8" NPT	1

Selection Information

General

The Racor Marine Diesel Spin-on Series feature a variety of compact sizes to fit most installations and cramped engine compartments.

Mounting Heads:

These units feature multiple fuel ports and many have more than one inlet or outlet. All have a unitized mounting bracket. The 200 and 400 Series heads feature a built-in, hand operated fuel priming pump to simplify servicing procedures.

Filters:

All units feature spin-on replaceable filters and contaminant collection bowls except for the high-pressure 110A. All units may be specified with an in-bowl water probe when used with diesel or kerosene applications.

High-capacity Aquabloc™ filter elements stop water and remove solid contamination. A 10 micron filter (or secondary and even final) is used to filter fuel which is known to be of good quality. A 2 micron filter, used with the 120R model, (or final filter) is the finest filtration available and is the last filter used prior to engine ingestion.

A simple rule to remember is the finer the filtration, the more frequent the filter change. (*Carry extra filters on board*).

Reusable Collection Bowls:

The metal bowls used with these models feature an NPT tapered thread plug for removing contaminants. An optional UL Listed shut-off drain valve may be ordered to simplify servicing.

Options -Available for Diesel fuel systems only.

Water Probe RK21069. When used with a Racor Water Detection Module, the operator can be alerted of a high-water condition, even while the equipment is operating. The bowl is then drained of water at the earliest convenience. Note: A Racor Water Detection Module is needed to work with this probe. See Accessories. Water Probe RK30880. Same features as above, except the 12 or 24 vdc electronic detection module is built-in the probe housing. Includes a detachable connector. See Accessories. **Danger! Do not use water probes with gasoline applications. This could cause an explosion.**

SELECTION

1. Along with the information you obtained in SECTION 2, SELECTION (page 94), consider the following: Are there any space limitations in the available location? The location should provide adequate space for removing the element, draining off contaminants from the bowl (and operating the primer pump on 200 and 400 Series models).
2. What filtration rating is needed? 2, 10 or 30 micron?
3. What options are needed? Water probe and/or a bowl shut-off drain valve?

Using this information, select a unit from the next page, or check the models which follow to find the right unit for your application.

For additional information, call your Racor dealer or call Racor customer service at (209) 521-7860 or (800) 344-3286, 6:00 AM to 5:00 PM, Pacific Time, or e-mail us from our website, www.parker.com/racor.

Model Illustrations

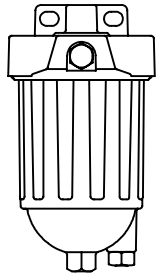

110A

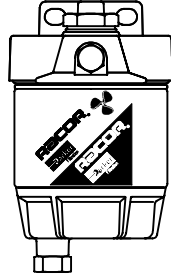

120RMAM

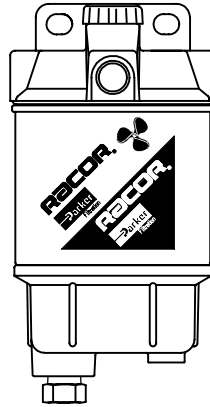

200RMAM Series



400MAM Series

Special Notes

1. Above units feature metal bowls and are approved for diesel service and are UL Listed, USCG Accepted.
2. Model 110A may be used in pressure applications (up to 100 PSI) and gasoline service. UL Listed.
3. The 200RMAM and 400MAM Series units include the head mounted hand priming pump as standard.
4. The 4120MAM model features large 3/4" UNF ports for high-flow, low-restriction applications.
5. Allow at least 2 inches (51 mm) clearance under the units for element replacement and water collection.
6. For additional information and availability, contact customer service: (800) 344-3286, 6 AM to 5 PM, Pacific Time.



Specifications

BASIC MODELS		110A	120RMAM	215RMAM	230RMAM	245RMAM	445MAM	460MAM	490MAM	4120MAM
Maximum Flow Rate	GPH	15 / 35 ¹	15	15	30	45	45	60	90	120
	LPH	57 / 132 ¹	57	57	114	170	170	227	341	454
Port Size		1/4"NPT	1/4"NPT	1/4"NPT	1/4"NPT	1/4"NPT	3/8"NPT	3/8"NPT	3/8"NPT	3/4"UNF
Number of Ports		4	4	3	3	3	4	4	4	4
Filter Element		R11T	R12SUL	R15TUL	R20TUL	R25TUL	S3204TUL	S3211TUL	S3201TUL	S3201TUL
Center threads		N/A	M18 X 1.5	1"-14	1"-14	1"-14	1"-14	1"-14	1"-14	1"-14
Height	in./mm	6/152	5.7/145	8.3/211	9.0/229	10.5/267	9.4/239	10.8/275	12.8/324	12.8/324
Width	in./mm	3.2/81	3.2/81	4/102	4/102	4/102	4.5/114	4.5/114	4.5/114	4.5/114
Depth	in./mm	3.2/81	3.2/81	4/102	4/102	4/102	4.8/121	4.8/121	4.8/121	4.8/121
Weight	Lbs./kgs.	1.3/0.59	1.3/0.59	1.8/0.80	2/0.90	2.2/1	2.9/1.3	3.1/1.4	3.3/1.5	3.3/1.5
Clean Press.Drop	PSI	0.15	0.15	0.12	0.31	0.61	0.17	0.30	0.35	0.45
	kPa	1.08	1.08	0.83	2.14	4.21	1.20	2.07	2.41	3.10
Max.Allowable Pressure	PSI	100	7	30	30	30	15	15	15	15
	kPa	689	48	207	207	207	103	103	103	103
Bowl Water Capacity	ml	36	52	58	58	58	58	58	58	58
Operating Temperature		- 40° / +255° F / - 40° / +121° C								

¹ Flow rate for gasoline applications.

Marine Diesel Spin-on Series

Models 110A

SPECIFICATIONS are found on the introduction page.

110A	Replacement Service Element SERVICE ELEMENT INCLUDES LID SEAL.
<u>Basic Model</u> 15 GPH Diesel / 35 GPH Gasoline Two piece die-cast aluminum construc- tion.	R11T 10 Micron -Recommended <i>for Primary or Secondary* Filtration</i> *Consult engine manufacturer or Racor Distributor.

Mounting Hole Pattern

-Refer to Diesel Spin-on Series introduction page for filter dimensions.

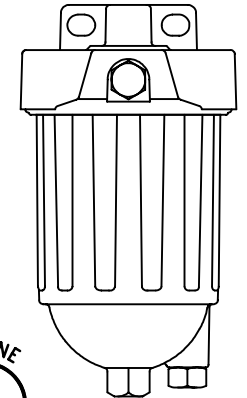
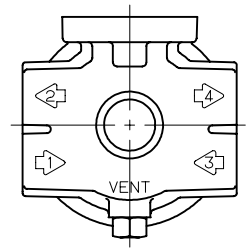
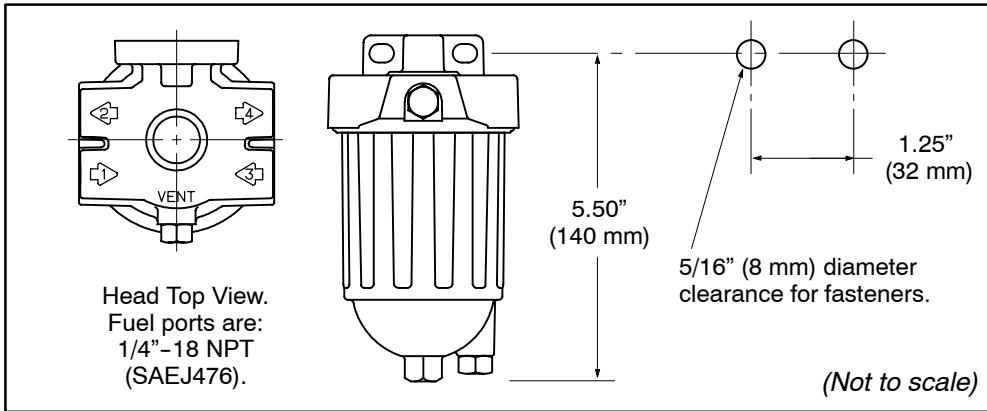

110A

Performance Graphs

-These results are from controlled laboratory tests. Field results may vary by application.

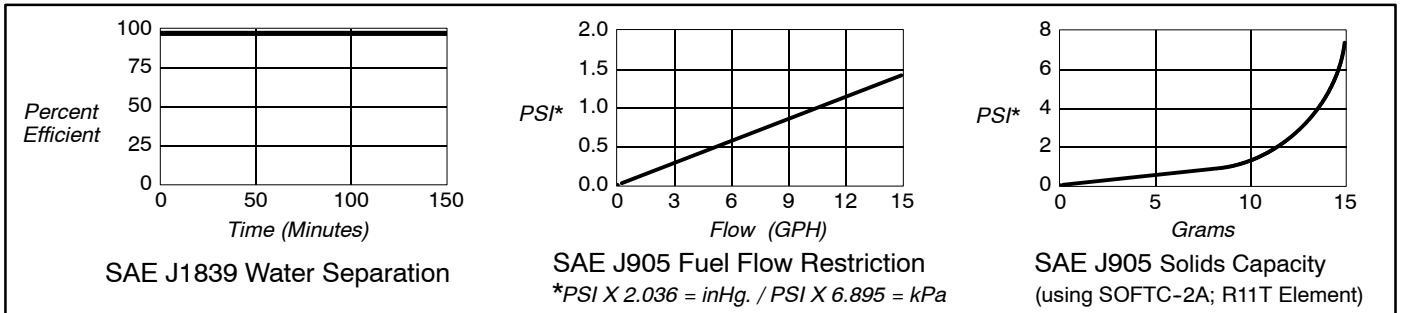

Parts List

The circled number corresponds to the item number shown in the parts list below.

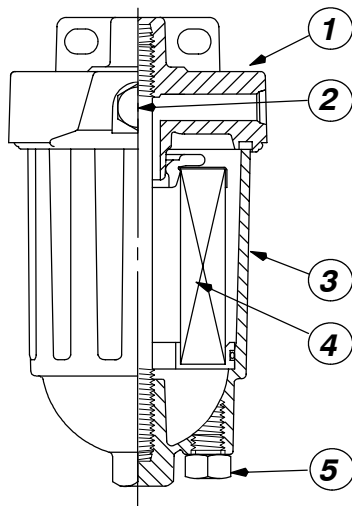

Item/Part No.	Description	Case Qty.
1 RK21361	110A Head, 1/4"NPT Ports	1
2 RK10110	Metal Vent Plug, 3/8"-24 UNF	1
3 RK21364	110A Housing	1
4 R11T	Replacement Element	12
5 RK20022	Metal Plug, 1/2"-20 UNF	1
RK21363	110A Gasket/O-ring Kit	1
21410	Installation Instructions	

SPECIFICATIONS are found on the introduction page.

120RMAM	Replacement Service Element SERVICE ELEMENT INCLUDES SEALS.
Basic Model 15 GPH Head and bowl are die-cast aluminum.	R12SUL 2 Micron -Recommended for Secondary (Final) Filtration <i>*Consult engine manufacturer or Racor Distributor.</i>

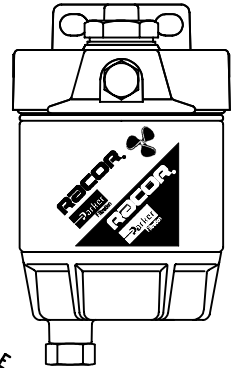
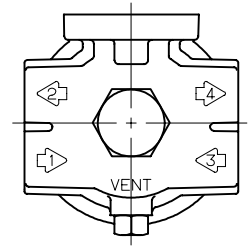

120RMAM

Mounting Hole Pattern

-Refer to Diesel Spin-on Series introduction page for filter dimensions.

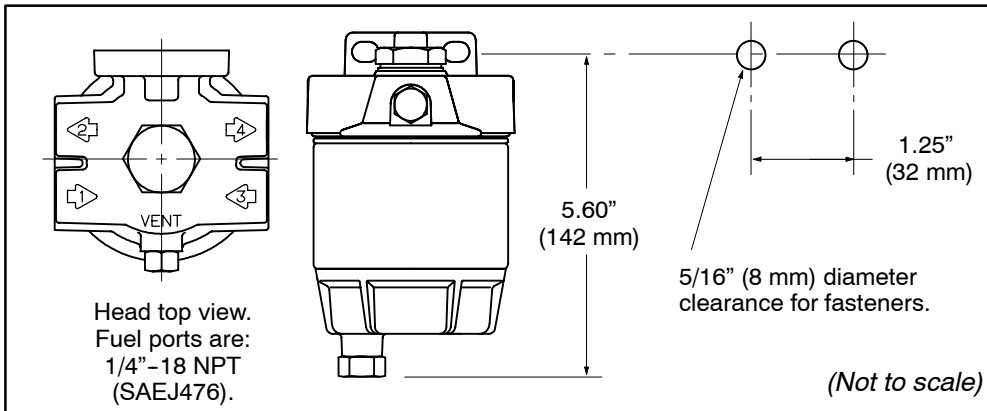

Performance Graphs

-These results are from controlled laboratory tests. Field results may vary by application.

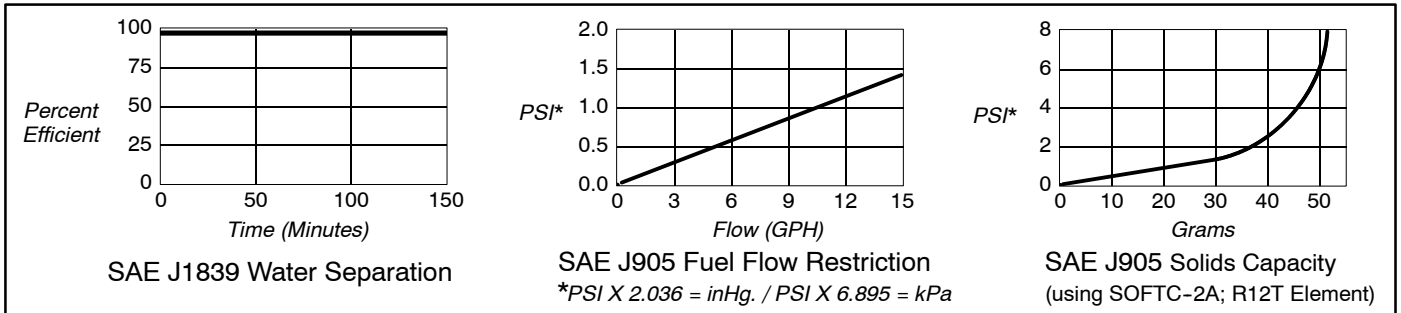

Parts List

The circled number corresponds to the item number shown in the parts list below.

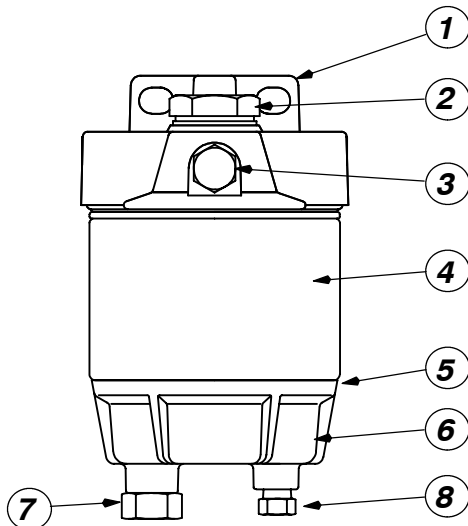

Item/Part No.	Description	Case Qty.
1 RK10117	Head, 1/4" NPT Ports	1
2 RK10006	Head Bolt Assembly	1
3 RK10110	Metal Vent Plug, 3/8"-24 UNF	1
4 R12SUL	Replacement Element 2 Micron, UL Recognized	20
5 RK10012	Bowl O-ring	1
6 RK10109	Metal Bowl	1
7 RK20022	Metal Plug, 1/2"-20 UNF	1
8 918-N2	Steel Drain Plug, 1/8"NPT	1
RK12041	Metal Plug, 1/4" NPT	1
RK10063	Gasket/O-ring Kit	1
10218	Installation Instructions, 120RMAM	

Marine Diesel Spin-on Series

Model 215, 230, 245RMAM

SPECIFICATIONS are found on the introduction page.

245RMAM	Replacement Service Element SERVICE ELEMENT INCLUDES SEALS.
215RMAM: 15 GPH 230RMAM: 30 GPH 245RMAM: 45 GPH Includes primer pump and metal bowl.	215 use R15TUL (10 Micron) 12/case 230 use R20TUL (10 Micron) 12/case 245 use R25TUL (10 Micron) 12/case

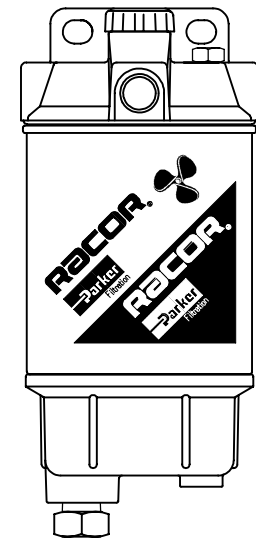

245RMAM shown



Mounting Hole Pattern

-Refer to Diesel Spin-on Series introduction page for filter dimensions.

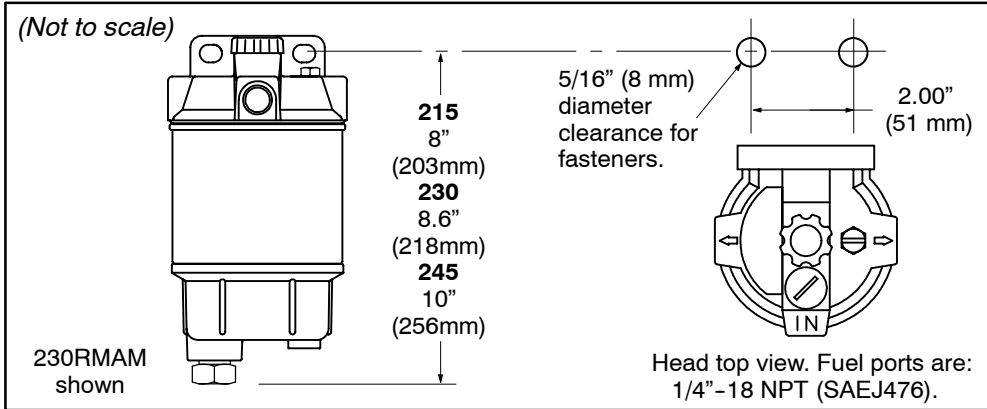

Performance Graphs

-These results are from controlled laboratory tests. Field results may vary by application.

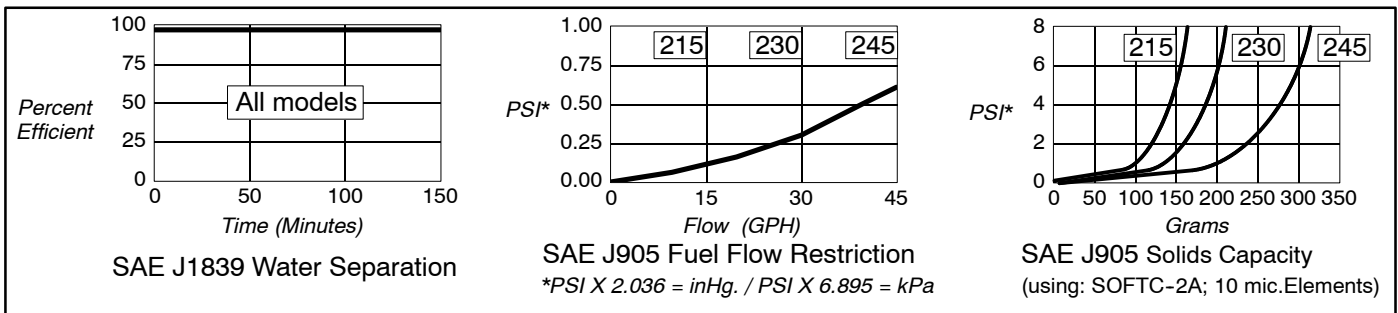

Parts List

The circled number corresponds to the item number shown in the parts list below.

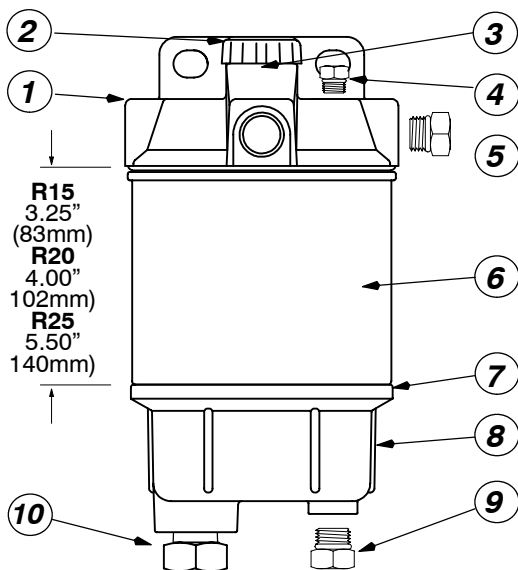

Item/Part No.	Description	Case Qty.
1	RK20046 Head, 1/4" NPT Ports	1
2	RK20025 Primer Pump Assembly	1
3	RK20011 Check Ball and Plastic Cap	1
4	RK20742 Metal Check Ball Cap	1
5	RK10110 Metal Vent Plug, 3/8"-16 UNF	1
6	RK12041 Metal Plug, 1/4" NPT	1
7	See 'Replacement Service Element' box above	
8	RK22244 Bowl O-ring	20
9	RK22368 Beige Metal Bowl (with 3/8 NPT drain and 1/2"-20 probe ports)	1
10	RK20022 Metal Plug, 1/2"-20 UNF	1
	918-N6 Steel Plug, 3/8" NPT	1
	RK20075 Complete Gasket/O-ring Kit	1
	22360 Installation Instructions, 200 Series	

Marine Diesel Spin-on Series Models 445, 460, 490, 4120MAM

SPECIFICATIONS are found on the introduction page.

How to Order -The example below illustrates how the part numbers are constructed.

445MAM	P	10
445MAM: 45 GPH 460MAM: 60 GPH 490MAM: 90 GPH 4120MAM: 120 GPH The powder coated head includes a hand primer pump with 2 inlets & outlets. The metal bowl is standard.	Water Probe: ¹ Specify 'P' for an in-bowl water probe. (Racor part number RK21069). Omit 'P' if not desired.	Element Filtration Rating: These units are standard with a 10 micron element. Add '10' to the part number.
¹ Order a water detection module separately from the Marine Accessories Section.		

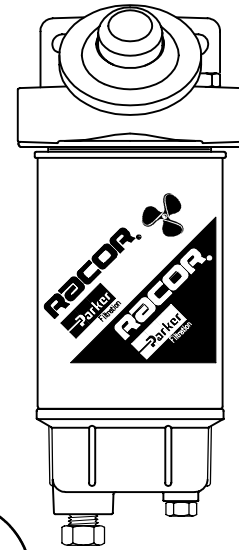

490MAM

Replacement Service Elements -Service elements include seals.

445MAM	use	S3204TUL	(10 Micron)	12 per case
460MAM	use	S3211TUL	(10 Micron)	12 per case
490MAM	use	S3201TUL	(10 Micron)	12 per case
4120MAM	use	S3201TUL	(10 Micron)	12 per case



Performance Graphs

-These results are from controlled laboratory tests. Field results may vary by application.

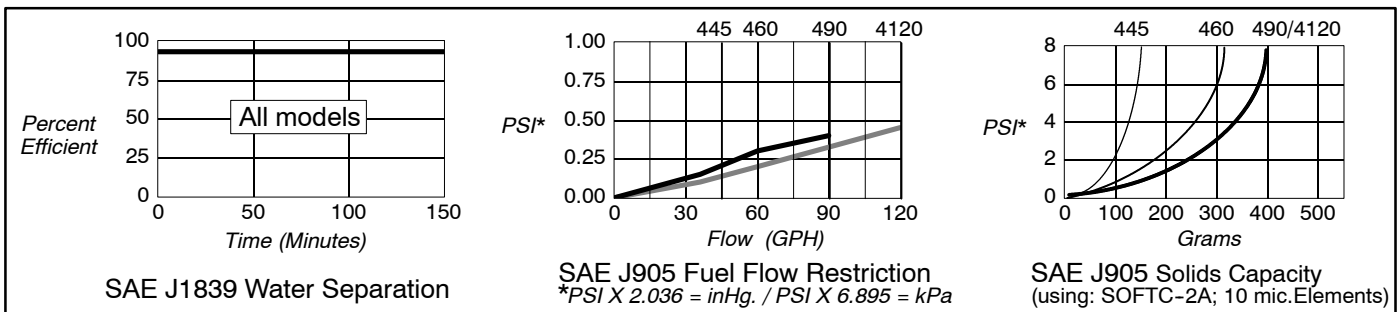

Mounting Hole Pattern / Parts List

The circled number corresponds to the item number shown.

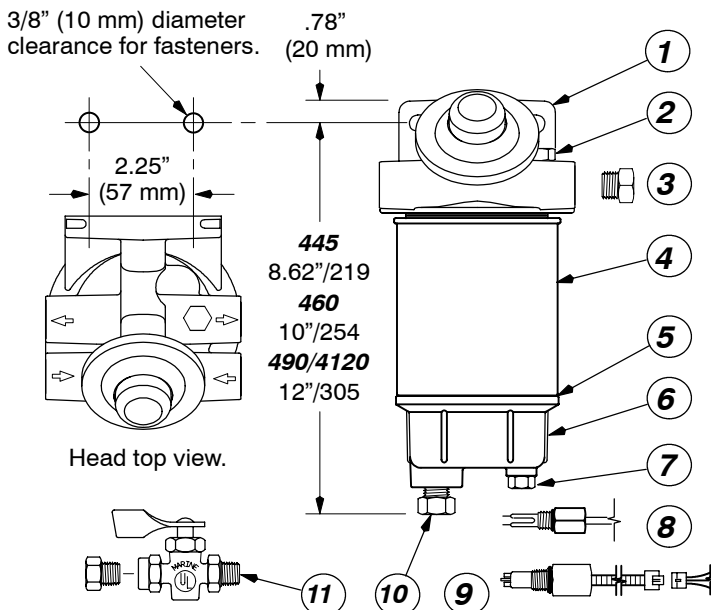

Item/Part No.	Description	Case Qty.
1	RK22425 Mounting Head, 3/8"NPT	1
	RK22270 4120 Mounting Head, 3/4"UNF	1
2	RK10110 Vent Plug (metal)	1
3	01SP-6S Metal Plug, 3/8" NPT	1
4	S3204TUL 445 Service Element, 10 micron	12
	S3211TUL 460 Service Element, 10 micron	12
	S3201TUL 490/4120 Service Element, 10 mic.	12
5	RK30076 Bowl O-ring	20
6	RK30495 Beige Metal Bowl, 1/4"NPT & 1/2"UNF Ports	1
7	RK20022 Metal Plug, 1/2"-20 UNF	1
8	RK21069 ¹ Water Probe, 1/2"-20 UNF	1
9	RK30880 Water Probe with Electronics	1
10	918-N4 Steel Plug, 1/4" NPT	1
11	RK19492 UL Listed Marine Shut-off Valve	1
	22490 Installation Instructions, 400 Series	

¹ Use with water detection module. See Accessories Section.

Selection Information

General

Racor Turbine Series Fuel Filter/Water Separators have been protecting engines from water, dirt, foulants and other contaminants for over 30 years using a patented three-stage process:

- 1. Separation.** The turbine centrifuge separates solids and 'free' water through centrifugal action. Although the turbine has no moving parts, over 30% of the contaminants are removed here.
- 2. Coalescing.** Smaller water droplets and solids coalesce on the specially designed conical baffle and fall to the collection bowl.
- 3. Filtration.** Engines benefit from near 100% water separation and fuel filtration with Racor's proprietary Aquabloc™ water repelling media.

The units are designed for installation on the suction (vacuum) side of the fuel transfer pump for best efficiency but may be installed on the pressure side up to 15 PSI.

Filters:

High-capacity Aquabloc™ replaceable cartridge elements stop water and remove solid contamination and are available in 2, 10 or 30 micron. Boat owners can specify their filtration needs based on application, fuel quality, operating climates and maintenance schedules.

A 30 micron filter (or primary filter) is used to filter raw fuel (or poor quality fuel) before it can be further filtered by finer medias such as a 10 or 2 micron. A 10 micron filter (or secondary and even final) is used to filter fuel which is known to be of good quality. A 2 micron filter (or final filter) is the finest filtration available and is the last filter used prior to engine ingestion.

A simple rule to remember is the finer the filtration, the more frequent the filter change. (*Carry extra filters on board*).

Collection Bowls:

The see-thru bowls used with these models won't discolor from alcohol, additives or UV light and feature NPT tapered thread plug for removing contaminants. An optional UL Listed shut-off drain valve may be ordered to simplify servicing. For gasoline or severe service in diesel applications, specify metal bowls, only.

Options –Available for Diesel fuel systems only.

Water Probe RK21069. All units may be ordered with an in-bowl water probe to alert the operator of a high-water condition, even while the equipment is operating. The bowl is then drained of water at the earliest convenience. Note: A Racor Water Detection Module is needed to work with this probe. See Accessories.

Water Probe RK30880. Same features as above, except the 12 or 24 vdc electronic detection module is built-in the probe housing. Includes a detachable connector. See Accessories.

Accessories

The condition of the filter may be monitored using a vacuum restriction gauge. See the Accessories Section.

SELECTION

1. Along with the information you obtained in SECTION 2, SELECTION (page 94), consider the following:
Are there any space limitations in the available location? The location should provide adequate overhead space for removing the element and underneath space for draining off contaminants from the bowl.
2. What filtration rating is needed? 2, 10 or 30 micron?
3. What options are needed? Water probe and/or a bowl shut-off drain valve?
4. Can the engine be shut down for servicing?
For engine(s) that cannot be shut-down if servicing becomes necessary, specify only MAV or MAX units.

Using this information, select a unit from the following page for your application.

For additional information, call your Racor dealer or call Racor customer service at (209) 521-7860 or (800) 344-3286, 6:00 AM to 5:00 PM, Pacific Time, or e-mail us from our website, www.parker.com/racor.

Model Illustrations

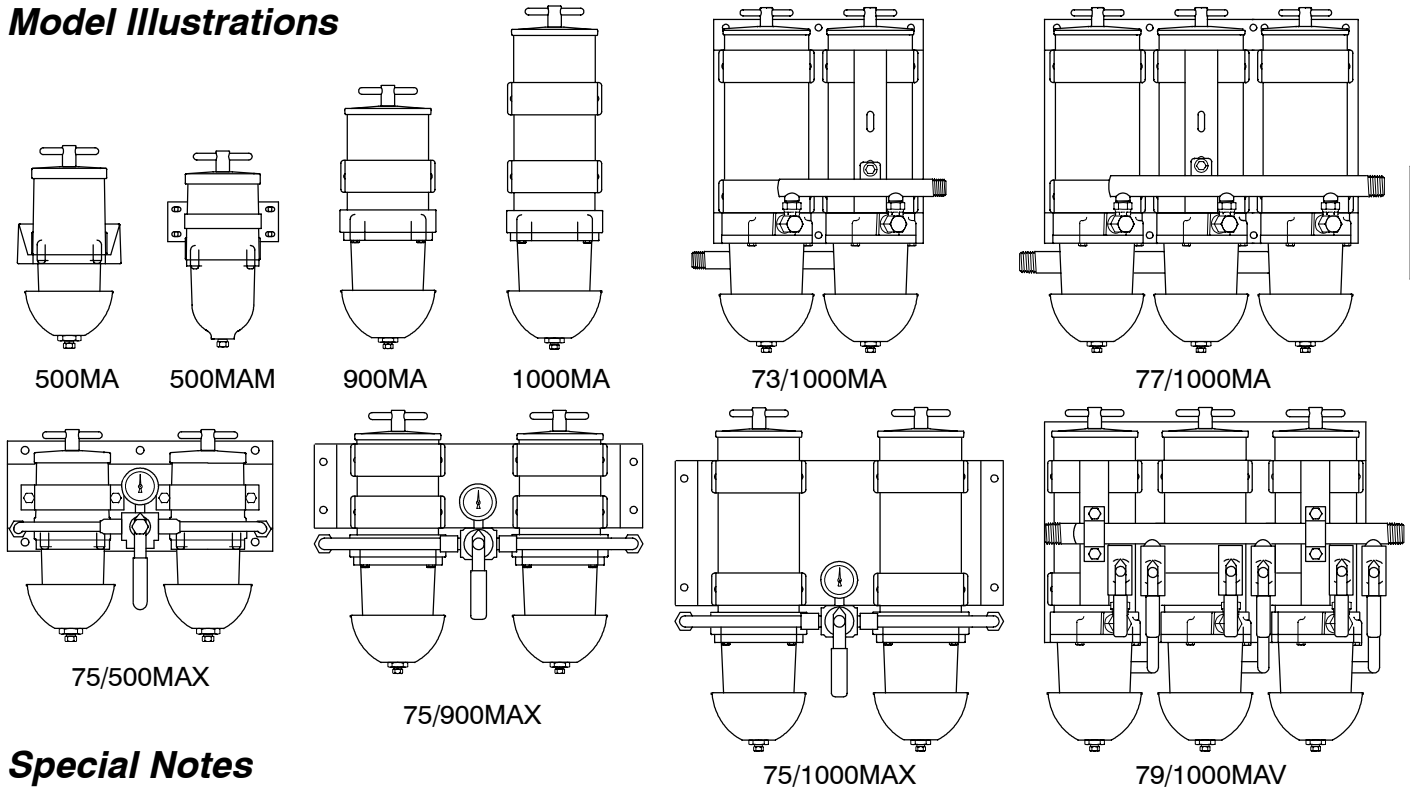

Special Notes

1. See-thru bowl MA / MAX / MAV units are approved for Diesel service only. UL Listed, USCG Accepted.
2. Metal bowl MAM / MAXM units are approved for Gasoline and Diesel service. UL Listed, USCG Accepted.
3. For additional info. and availability, contact customer service at: (800) 344-3286, 6 AM to 5 PM, Pacific Time.



Specifications

BASIC MODELS		500MA	900MA	1000MA	73/1000MA	75/500MAX	75/900MAX	75/1000MAX	77/1000MA	79/1000MAV
Maximum Flow Rate	GPH LPH	60 227	90 341	180 681	360 1363	120 454	180 681	360 1363	540 2044	540 2044
Port Size		3/4"-16 ^{1,2}	7/8"-14 ¹	7/8"-14 ¹	3/4"-14 ³	3/4"-16 ¹	7/8"-14 ⁴	7/8"-14 ⁴	1"-11 1/2 ³	3/4"-14 ³
Filter Element		2010 Series	2040 Series	2020 Series	2020 Series	2010 Series	2040 Series	2020 Series	2020 Series	2020 Series
Height	in./mm	11.5/292	17/432	22/559	22/559	11.5/292	17/432	22/559	22/559	22/559
Width	in./mm	5.8/147	6/152	6/152	16.5/419	14.5/368	18.8/476	18.8/476	21.5/546	21.5/546
Depth	in./mm	4.8/122	7/178	7/178	12/305	9.5/241	11/279	11/279	12/305	11.8/300
Weight	Lbs./kgs.	4/1.7	6/2.7	10/4.5	26/11.8	17/7.7	23/10.4	30/13.6	39/17.7	52/23.6
Clean Pressure Drop	PSI kPa	0.25 1.72	0.34 2.4	0.49 3.4	1.7 11.7	0.70 4.83	1.7 11.7	3.7 25.5	1.7 11.7	2.5 17.2
Max. Allowable Pressure	PSI kPa	15 103	15 103	15 103	15 103	15 103	15 103	15 103	15 103	15 103
Bowl Water Capacity	ml	110	305	305	610	220	610	610	915	915
Overhead Clearance ⁵	in. mm	4 102	5 127	10 254	10 254	4 102	5 127	10 254	10 254	10 254
Operating Temperature		- 40° / +255° F / - 40° / +121° C								

¹ SAEJ1926 O-ring boss ² Effective 1/15/96, call factory for other sizes. ³ SAEJ476 (NPT) National Pipe Tapered thread
⁴ SAEJ514 (JIC) Joint Industry Council, 37° male flare ⁵ Required for element removal / servicing.

Marine Turbine Series

Model 500MA

SPECIFICATIONS are found on Turbine Series introduction page.

How to Order -The example below illustrates how the part numbers are constructed.

500MA	P	10
Basic Model 60 GPH Add 'M' for metal bowl Example: 500MAM	Water Probe. ¹ Add 'P' for an in-bowl water probe. (Omit if not desired).	Element Filtration Rating. Specify one: '2' for 2 micron '10' for 10 micron or '30' for 30 micron
¹ Must be used with Water Detection Kit. See Accessories Section.		

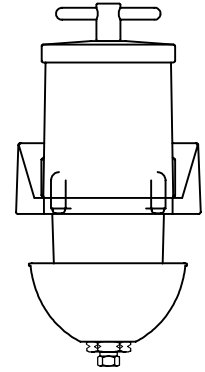

500MA

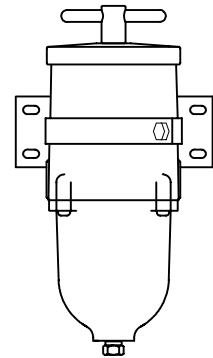

500MAM

Replacement Service Elements -For all Model 500 Series
SERVICE ELEMENT INCLUDES LID SEAL AND T-HANDLE O-RING.

2010SM-OR	2 Micron (Brown end caps) Recommended for Final /Secondary Filtration
2010TM-OR	10 Micron (Blue end caps) Recommended for Primary or Secondary Filtration
2010PM-OR	30 Micron (Red end caps) Recommended for Primary Filtration* Only. *A secondary/final filter is required downstream.

Mounting Hole Patterns -Refer to Turbine Series introduction page for filter dimensions.

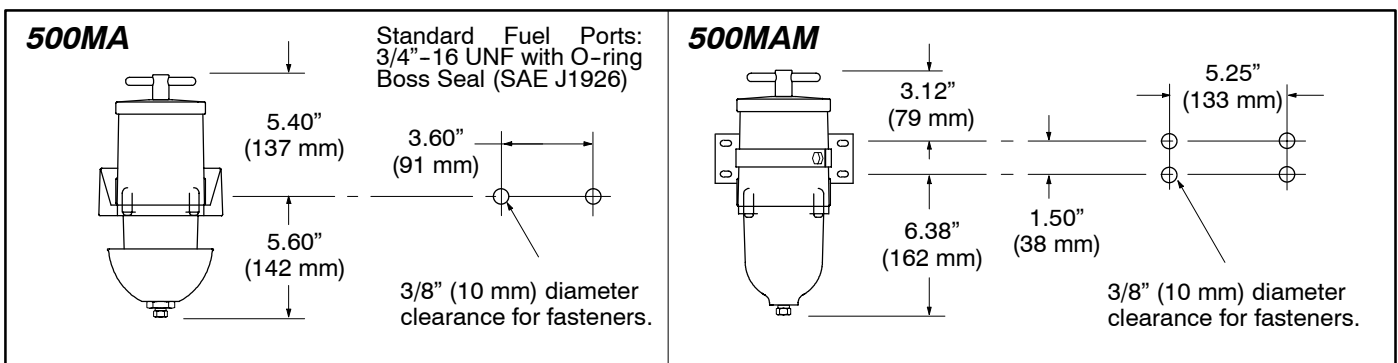

Performance Graphs -These results are from controlled laboratory tests. Field results may vary by application.

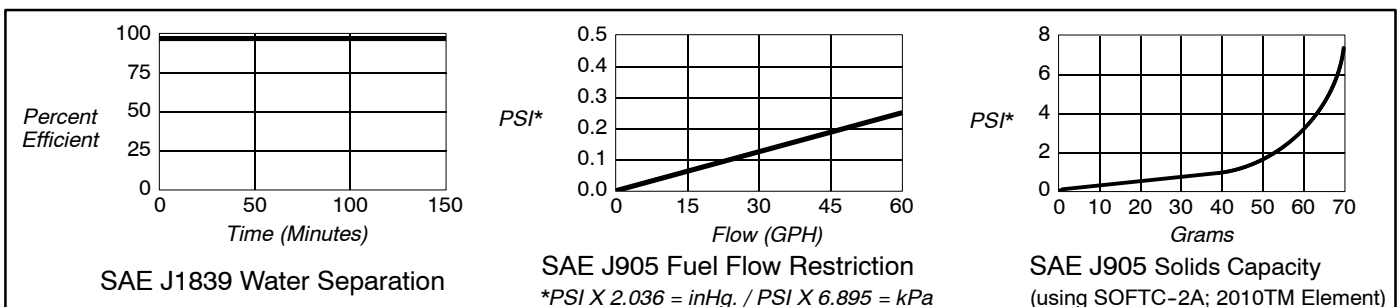
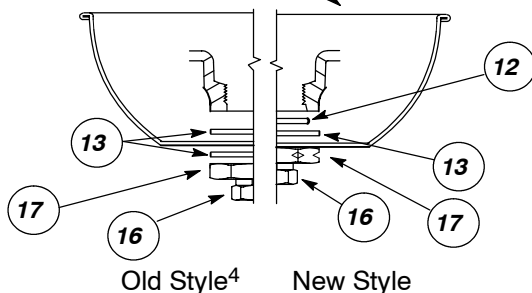
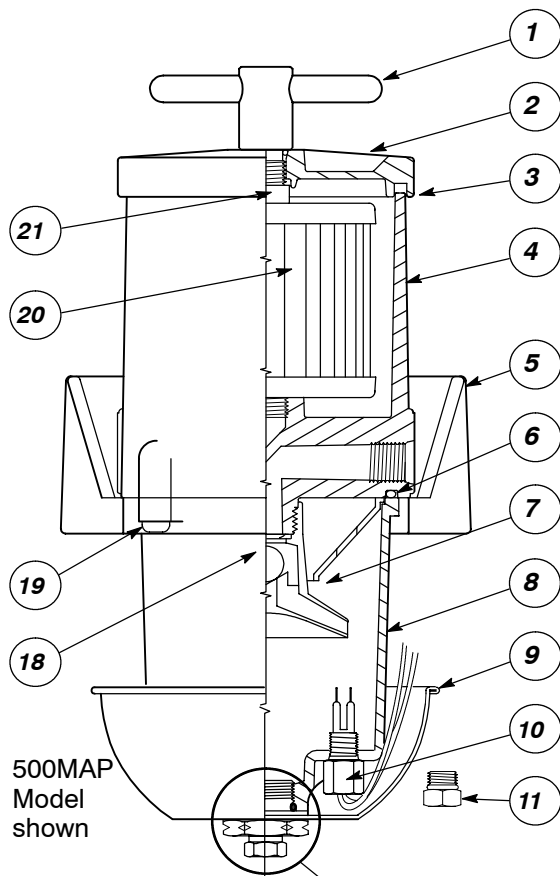
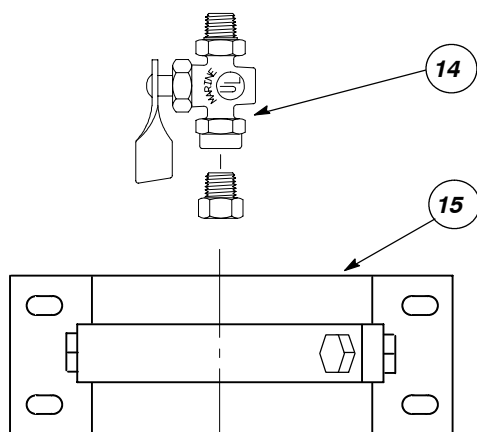

FIGURE 1. 500MA Series Cutaway View. The circled number corresponds to the item number shown below.



Drain Fitting Configurations



500MAM 3-Piece Bracket

Item	Part No.	Description	Case Qty.
1	RK11888	T-handle	1
	11350	T-handle O-ring	10
2	RK15078	Lid	1
3	15005	Lid Gasket	10
4	RK15377-01	Body, 3/4"-16 UNF Ports (MA, effective 1/15/96)	1
	RK15082	Body, 9/16"-18 UNF Ports (prior to 1/15/96)	1
5	RK15090	Mounting Bracket, unitized with Bowl Ring (MA)	1
6	15374	Bowl Gasket (supercedes 15009 O-ring-All models)	10
7	RK15013D	Turbine Centrifuge / Conical Baffle	1
8	RK15279-01	See-thru Bowl w/ Water Probe Plug, (MA)	1
	RK15301-01	Metal Bowl w/1/4"NPT Drain & Water Probe Port	1
9	RK15104 ¹	Heat Deflector Shield (MA)	1
10	RK21069 ²	Water Probe Assembly	1
11	RK20022	Metal Water Probe Port Plug	1
12	11340	Drain Fitting O-ring (New Style)	1
13	11041	Bowl Drain Washer (New and Old Style)	10
14	RK19492	Diesel Marine Shut-off Valve Kit.	1
15	RK15300	Mounting Bracket, 3-piece (MAM)	1
16	918-N4	Bowl plug, 1/4" NPT (Old and New Style)	1
17	11-1910	Bowl Drain Fitting (New Style)	1
	RK11-1910	Complete Bowl Drain Fitting Kit (New Style)	1
	11040	Bowl Drain Fitting (Old Style)	10
18	RK15010B	Check Ball w/ Seal	1
19	RK15081-01 ³	Phillips Head Capscrews 10-24 x 1" (4)	1
	RK15081 ³	Hex/Washer Head Capscrews 10-24 x 7/8" (4)	1
20	2010SM-OR	2 Micron Element w/ Seals	12
	2010TM-OR	10 Micron Element w/ Seals	12
	2010PM-OR	30 Micron Element w/ Seals	12
21	RK15079	Return Tube (w/ tapered pipe base threads)	1
22	RK15211	Seal Service Kit (all models- not shown)	1
	15335	Installation Instructions, 500MA	

¹ For replacement only. The Coast Guard does not accept 'FG' units converted to 'MA' configurations.

² For diesel service only. Must be used with a Water Detection Kit.

³ Models built prior to 2/96 use RK15081-01, after 2/96 use RK15081. (Fuel ports have 1 1/4" square boss on models made after 2/96).

⁴ Units built prior to Fall, 1998.

See Accessories Section.

SPECIFICATIONS are found on *Turbine Series introduction page*.

How to Order -The example below illustrates how the part numbers are constructed.

900MA	P	10
<u>Basic Model</u> 90 GPH Add 'M' for metal bowl Example: 900MAM	<u>Water Probe.</u> Add 'P' for an in-bowl water probe. ¹ (Omit if not desired).	<u>Element Filtration Rating.</u> Specify one: '2' for 2 micron '10' for 10 micron or '30' for 30 micron
¹ Must be used with Water Detection Kit. See Accessories Section.		

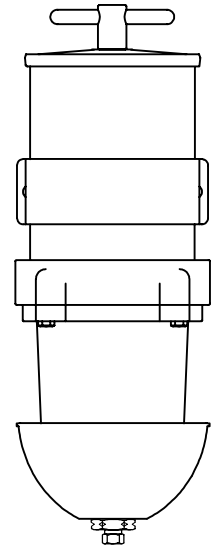

900MA



Replacement Service Elements -For all Model 900 Series
 SERVICE ELEMENT INCLUDES LID SEAL AND T-HANDLE O-RING.

2040SM-OR	2 Micron (Brown end caps) Recommended for Final /Secondary Filtration
2040TM-OR	10 Micron (Blue end caps) Recommended for Primary or Secondary Filtration
2040PM-OR	30 Micron (Red end caps) Recommended for Primary Filtration* Only. *A secondary/final filter is required downstream.

Mounting Hole Pattern -Refer to Turbine Series introduction page for filter dimensions.

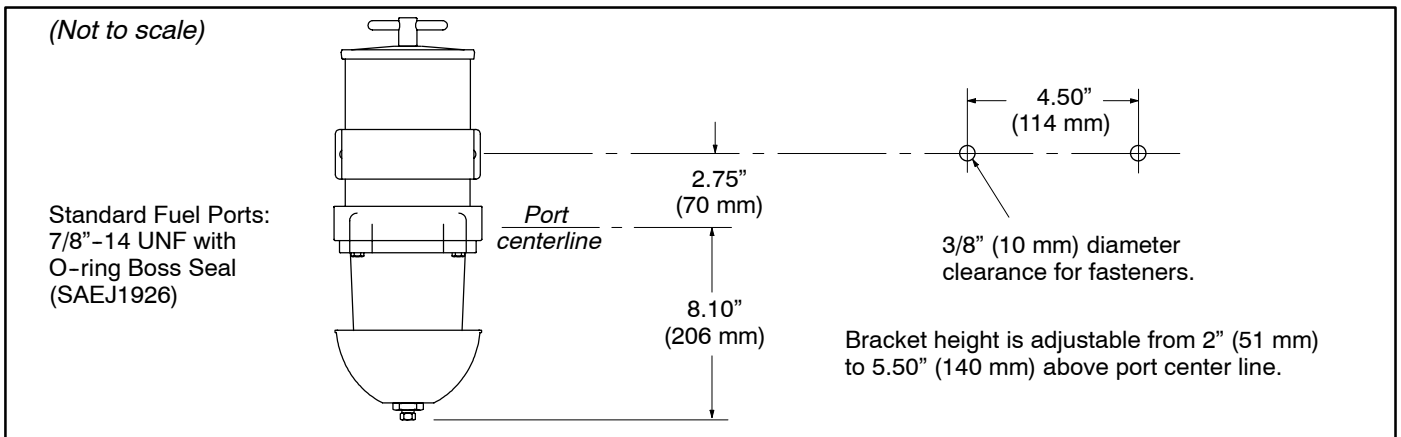

Performance Graphs -These results are from controlled laboratory tests. Field results may vary by application

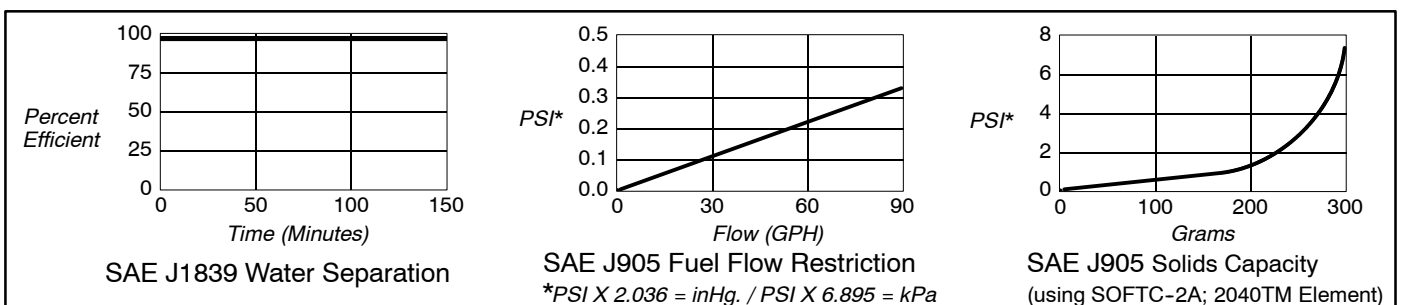
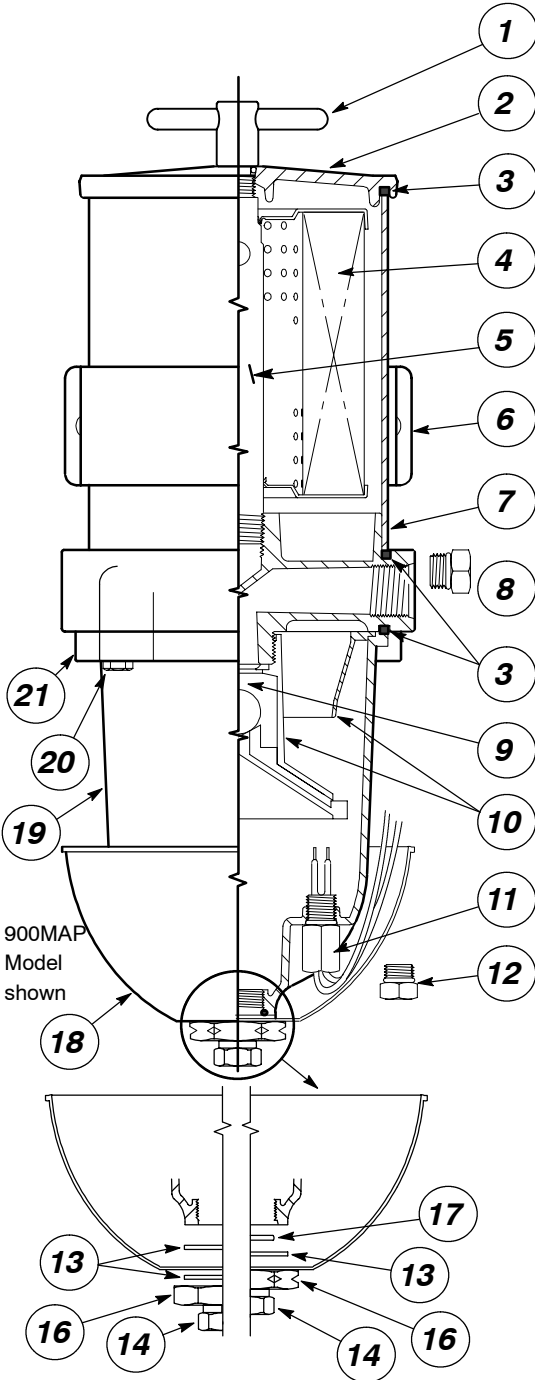
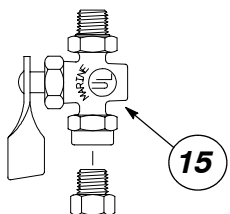

FIGURE 1. 900MA Series Cutaway View. The circled number corresponds to the item number shown below.



900MAP
Model
shown

Old Style³ New Style
Drain Fitting Configurations



Item	Part No.	Description	Case Qty.
1	RK11888	T-handle	1
	11350	T-handle O-ring	10
2	RK11005B	Lid	1
	RK11005B-02	Lid with Vent Port and Plug Kit (not shown)	1
3	11007	Square-cut Gasket (Lid & Bowl ring)	10
4	2040SMOR	2 Micron Element with Seals	12
	2040TMOR	10 Micron Element with Seals	12
	2040PMOR	30 Micron Element with Seals	12
5	RK19001	Return Tube (w/ tapered pipe body-end threads)	1
	RK19474	Return Tube (w/ straight body-end threads)	1
6	RK11815-101	Body Clamp Bracket	1
7	RK19002	Outer Cylinder	1
8	RK11-1679	Plastic Body Plug	1
9	RK11028B	Check Ball and Seal	10
10	RK11026D	Turbine Centrifuge / Conical Baffle	1
11	RK21069 ¹	Water Probe Assembly	1
12	RK20022	Metal Water Probe Port Plug	1
13	RK11341	Bowl Drain Gasket Kit (for New and Old Styles)	10
	11041	Bowl Drain Washer (New and Old Style)	1
14	918-N4	Bowl Plug, 1/4" NPT (New and Old Style)	1
15	RK19492	Diesel Marine Shut-off Valve Kit.	1
16	11-1910	Bowl Drain Fitting (New Style)	10
	RK11-1910	Complete Bowl Drain Fitting Kit (New Style)	1
	11040	Bowl Drain Fitting (Old Style)	10
17	11340	Drain Fitting O-ring (New Style)	1
18	RK11868 ²	Heat Deflector Shield (MA)	1
19	RK11-1606-1	Clear Bowl with Water Probe Port	1
	RK11734	Metal Bowl (MAM -not shown)	1
	RK11734-01	Metal Bowl w/ 1/4"NPT Drain & Water Probe Port	1
20	RK11542	Hex/Washer Head Capscrew, 1/4"-20 x 1" (4)	1
21	RK11037A	Bowl Ring	1
22	RK11-1404	Seal Service Kit (all models- not shown)	1
	19466	Installation Instructions, 900/1000MA	

¹ For diesel service only. Must be used with a Water Detection Kit.
² For replacement only. The Coast Guard does not accept 'FG' units converted to 'MA' configurations.
³ Units built prior to Fall, 1998
 See Accessories Section.

SPECIFICATIONS are found on *Turbine Series introduction page*.

How to Order -The example below illustrates how the part numbers are constructed.

1000MA	P	10
<u>Basic Model</u> 180 GPH Add 'M' for metal bowl Example: 1000MAM	<u>Water Probe.</u> ¹ Add 'P' for an in-bowl water probe. (Omit if not desired).	<u>Element Filtration Rating.</u> Specify one: '2' for 2 micron '10' for 10 micron or '30' for 30 micron
¹ Must be used with Water Detection Kit. See Accessories Section.		

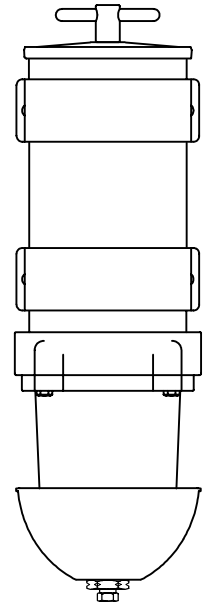

1000MA



Replacement Service Elements -For all Model 1000 Series
 SERVICE ELEMENT INCLUDES LID SEAL AND T-HANDLE O-RING.

2020SM-OR	2 Micron (Brown end caps) Recommended for Final /Secondary Filtration
2020TM-OR	10 Micron (Blue end caps) Recommended for Primary or Secondary Filtration
2020PM-OR	30 Micron (Red end caps) Recommended for Primary Filtration* Only. *A secondary/final filter is required downstream.

Mounting Hole Pattern -Refer to *Turbine Series introduction page* for filter dimensions.

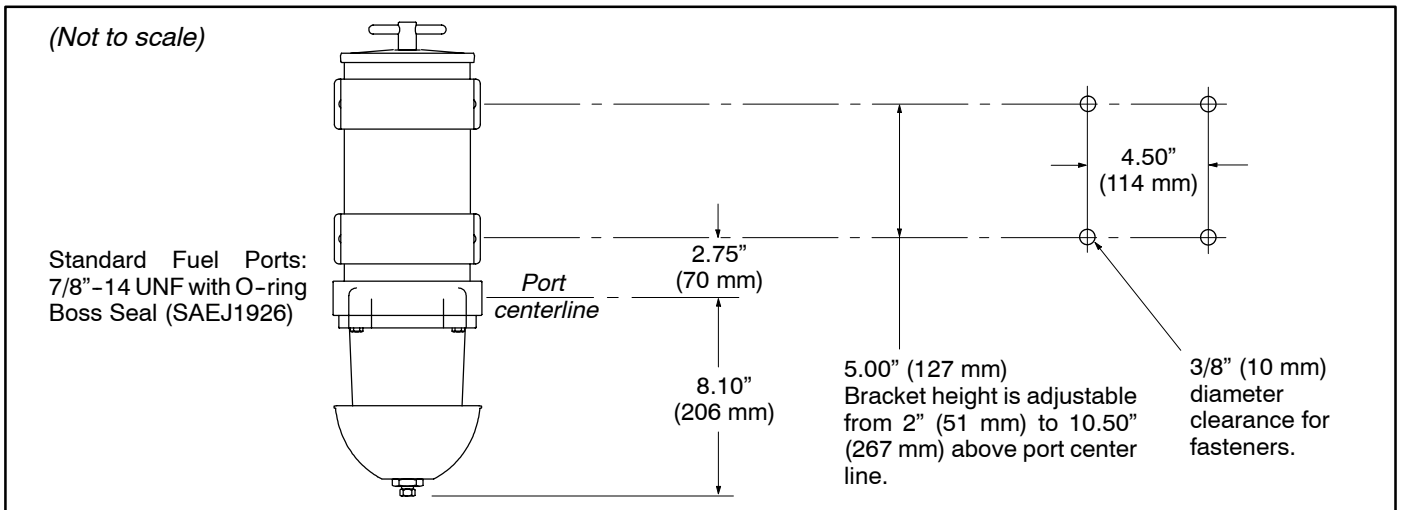

Performance Graphs -These results are from controlled laboratory tests. Field results may vary by application.

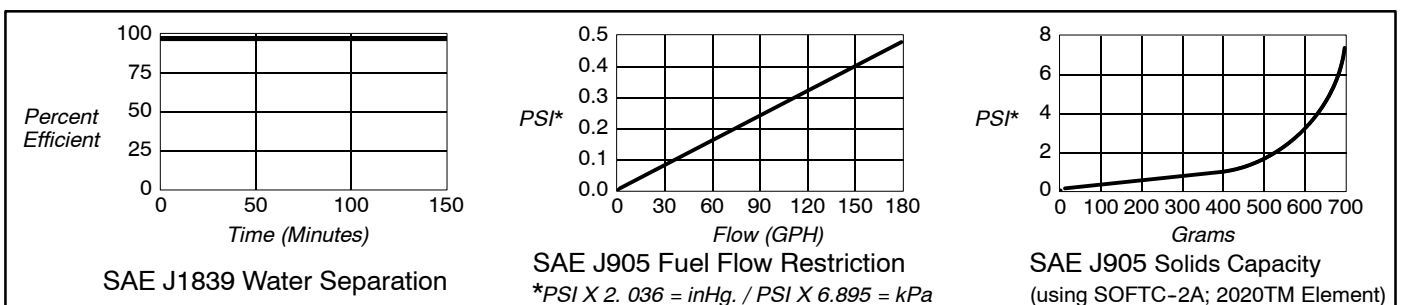
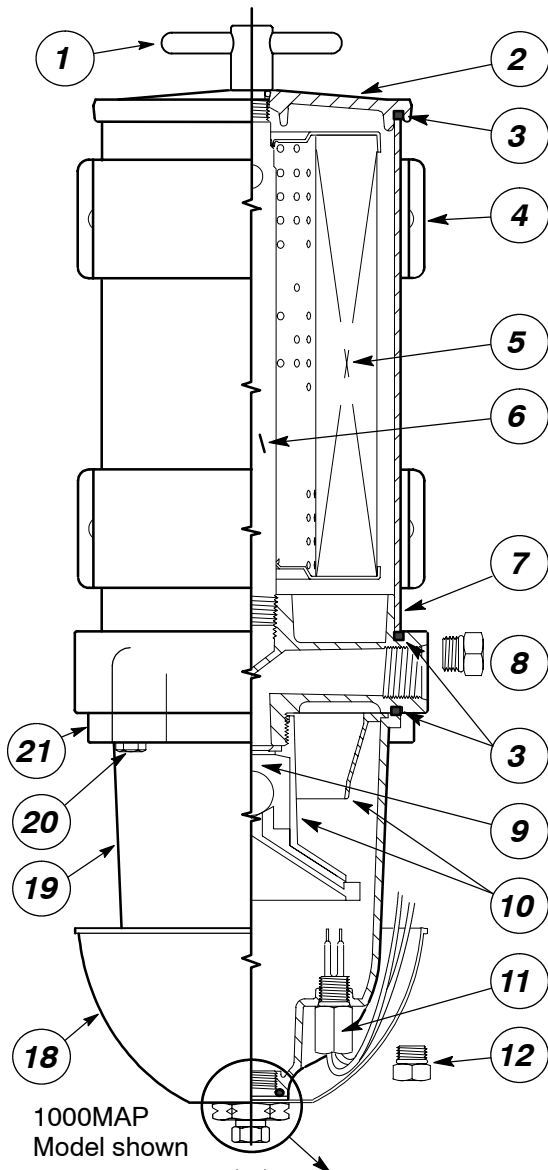
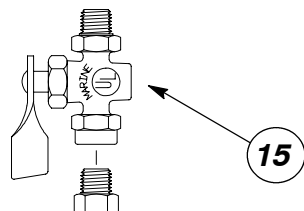
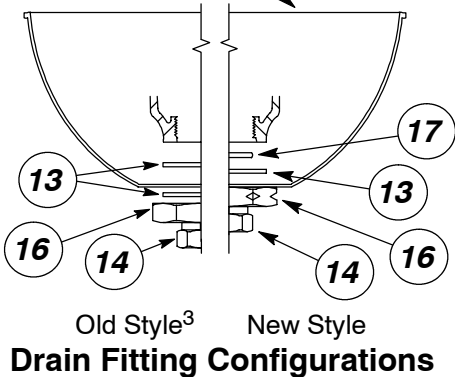

FIGURE 1. 1000MA Series Cutaway View. The circled number corresponds to the item number shown below.



Item	Part No.	Description	Case Qty.
1	RK11888	T-handle	1
	11350	T-handle O-ring	10
2	RK11005B	Lid	1
	RK11005B-02	Lid with Vent Port and Plug Kit (not shown)	1
3	11007	Square-cut Gasket (Lid & Bowl ring)	10
4	RK11815-101	Body Clamp Bracket	1
5	2020SMOR	2 Micron Element with Seals	12
	2020TMOR	10 Micron Element with Seals	12
	2020PMOR	30 Micron Element with Seals	12
6	RK11008	Return Tube (w/ tapered pipe body-end threads)	1
	RK11-1775	Return Tube (w/ straight body-end threads)	1
7	RK11021	Outer Cylinder	1
8	RK11-1679	Plastic Body Plug	1
9	RK11028B	Check Ball and Seal	10
10	RK11026D	Turbine Centrifuge / Conical Baffle	1
11	RK21069 ¹	Water Probe (MA Bowls)	1
12	RK20022	Metal Water Probe Port Plug	1
13	RK11341	Bowl Drain Gasket Kit (for New and Old Styles)	10
	11041	Bowl Drain Washer (New and Old Style)	1
14	918-N4	Bowl Plug, 1/4" NPT (New and Old Style)	1
15	RK19492	Shut-off Drain Valve Kit (for diesel use, only)	1
16	11-1910	Bowl Drain Fitting (New Style)	10
	RK11-1910	Complete Bowl Drain Fitting Kit (New Style)	1
	11040	Bowl Drain Washer (Old Style)	10
17	11340	Drain Fitting O-ring (New Style)	1
18	RK11868 ²	Heat Deflector Shield (MA)	1
19	RK11-1606-1	Clear Bowl with Water Probe Port	1
	RK11734	Metal Bowl (MAM -not shown)	1
	RK11734-01	Metal Bowl w/ 1/4"NPT Drain & Water Probe Port	1
20	RK11542	Hex/Washer Head Capscrew, 1/4"-20 x 1" (4)	1
21	RK11037A	Bowl Ring	1
22	RK11-1404	Seal Service Kit (all models- not shown)	1
	19466	Installation Instructions, 900/1000MA	

2



1 For diesel service only. Must be used with a Water Detection Kit.
 2 For replacement only. The Coast Guard does not accept 'FG' units converted to 'MA' configurations.
 3 Units built prior to Fall, 1998
 See Accessories Section.

Marine Turbine Series

Model 73/1000MA

SPECIFICATIONS are found on Turbine Series introduction page.

How to Order -The example below illustrates how the part numbers are constructed.

73/1000MA	P	10
<u>Basic Model</u> 360 GPH Add 'M' for metal bowl Example: 73/1000MAM	<u>Water Probe.</u> ¹ Add 'P' for an in-bowl water probe. (Omit if not desired).	<u>Element Filtration Rating.</u> Specify one: '2' for 2 micron '10' for 10 micron or '30' for 30 micron
¹ For use with Water Detection Kit only. See Accessories Section.		

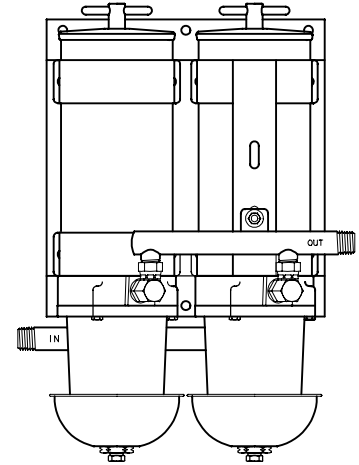

73/1000MA



Replacement Service Elements -Order two (2) per unit.
SERVICE ELEMENT INCLUDES LID SEAL AND T-HANDLE O-RING.

- 2020SM-OR** 2 Micron (Brown end caps)
Recommended for Final /Secondary Filtration
- 2020TM-OR** 10 Micron (Blue end caps)
Recommended for Primary or Secondary Filtration
- 2020PM-OR** 30 Micron (Red end caps)
Recommended for Primary Filtration* Only.
*A secondary/final filter is required downstream.

Mounting Hole Pattern -Refer to Turbine Series introduction page for filter dimensions.

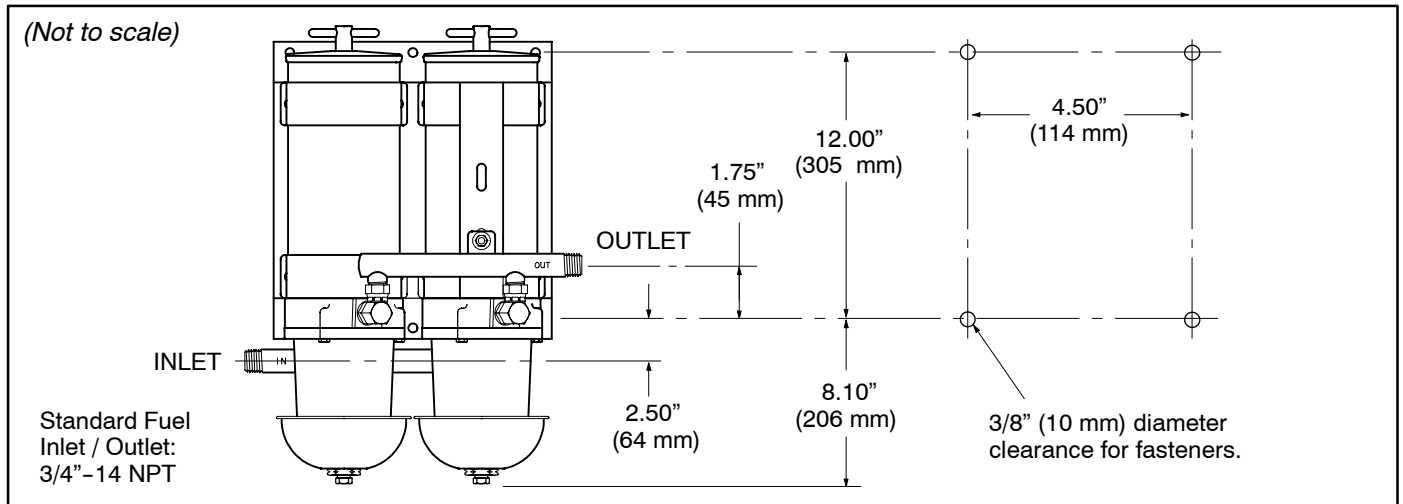

Performance Graphs -These results are from controlled laboratory tests. Field results may vary by application.

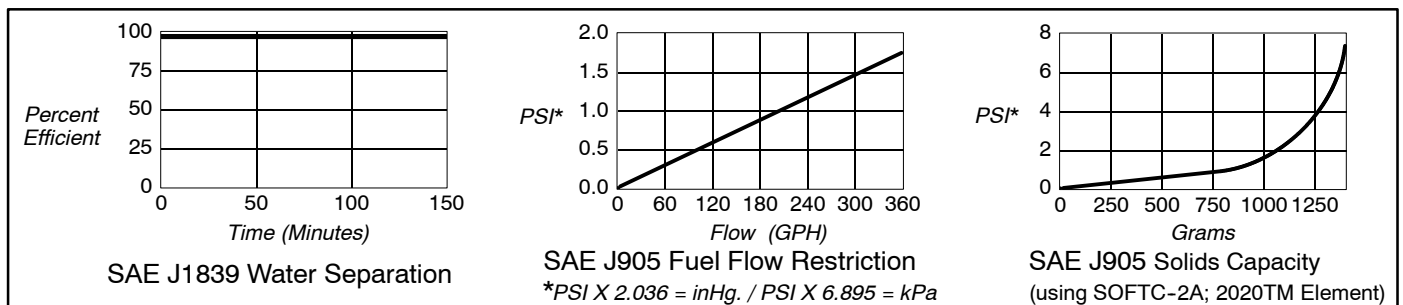
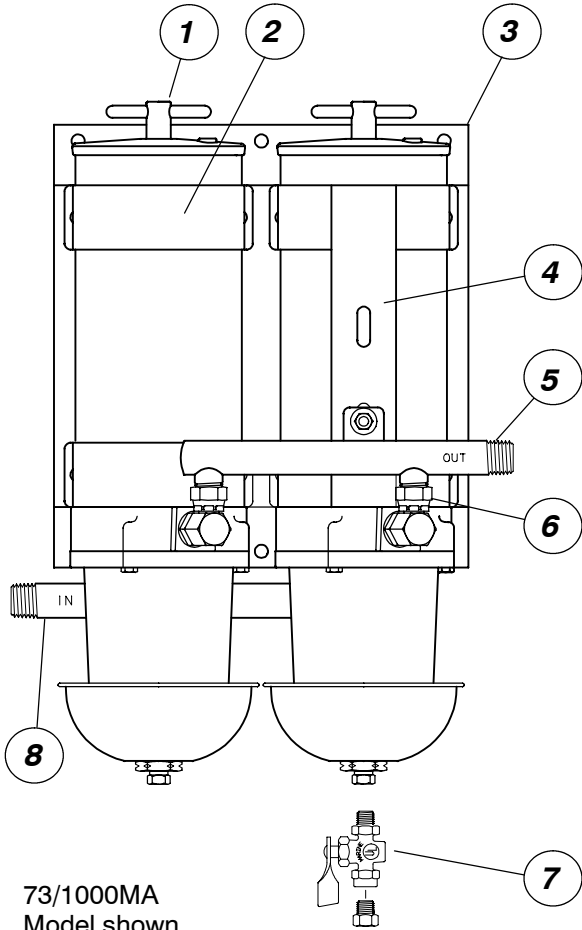

FIGURE 1. 73/1000MA Series. The circled number corresponds to the item number shown in the parts list below.



Item	Part No.	Description	Case Qty.
1	1000MA	Shell. Refer to Model 1000MA for a complete parts list	
2	RK11895	Clamp Bracket	1
3	11-1629	Dual unit Bracket	1
4	11895	Clamp Bracket Assembly	1
5	11923	Outlet Manifold	1
6	11072	Elbow Fitting, Parker #2507-10-8	1
7	RK19492	UL Listed Marine Drain Valve (order two for use with this unit)	1
8	11892	Inlet Manifold	1
	11-1831	Installation Instructions, 73/1000MA	

For Water Detection Kits and Manifold Conversion Kits, see the Accessories Section.

For parts not listed, call Racor customer service: (800) 344-3286, 6 AM to 5 PM, Pacific Time.

Marine Turbine Series

Model 75/500MAX

SPECIFICATIONS are found on Turbine Series introduction page.

How to Order -The example below illustrates how the part numbers are constructed.

75/500MAX	P	10
<u>Basic Model</u> 120 GPH Add 'M' for metal bowl Example: 75/500MAXM Note: All standard bowls include probe port plug.	<u>Water Probe.¹</u> Add 'P' for an in-bowl water probe. (Omit if not desired).	<u>Element Filtration Rating.</u> Specify one: '2' for 2 micron '10' for 10 micron or '30' for 30 micron
¹ Must be used with Water Detection Kit only. See Accessories Section.		

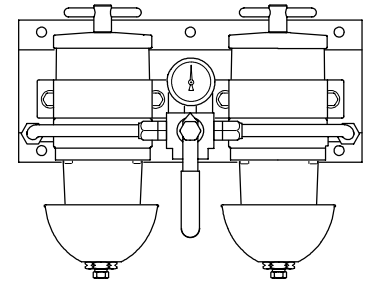

75/500MAX

Replacement Service Elements -Order two (2) per unit.
 SERVICE ELEMENT INCLUDES LID SEAL AND T-HANDLE O-RING.

2010SM-OR	2 Micron (Brown end caps) Recommended for Final /Secondary Filtration
2010TM-OR	10 Micron (Blue end caps) Recommended for Primary or Secondary Filtration
2010PM-OR	30 Micron (Red end caps) Recommended for Primary Filtration* Only. *A secondary/final filter is required downstream.



Mounting Hole Pattern -Refer to Turbine Series introduction page for filter dimensions.

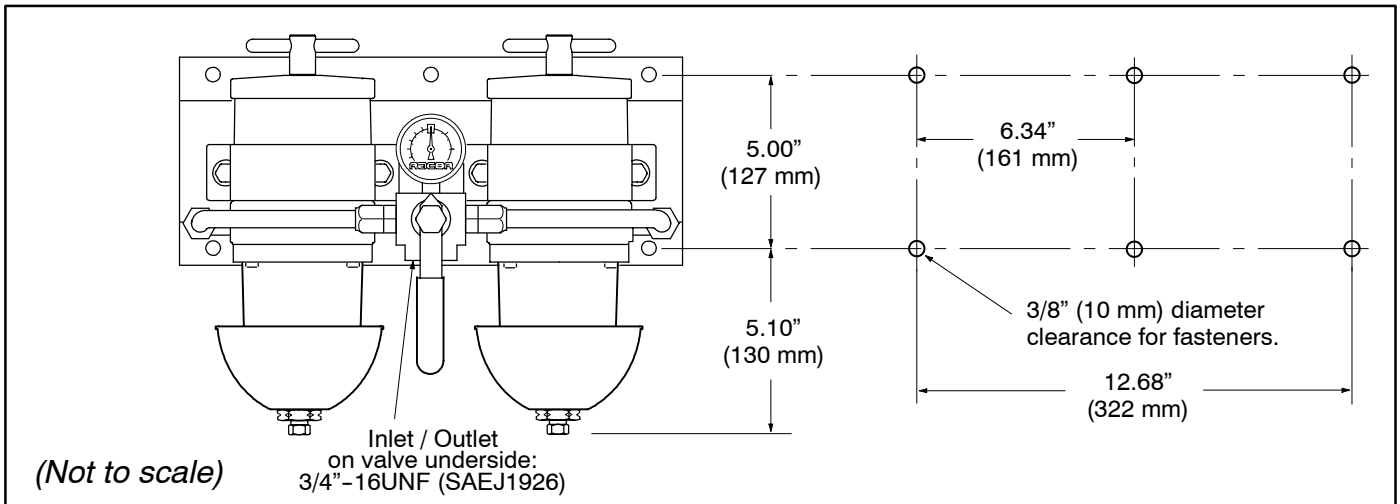

Performance Graphs -These results are from controlled laboratory tests. Field results may vary by application.

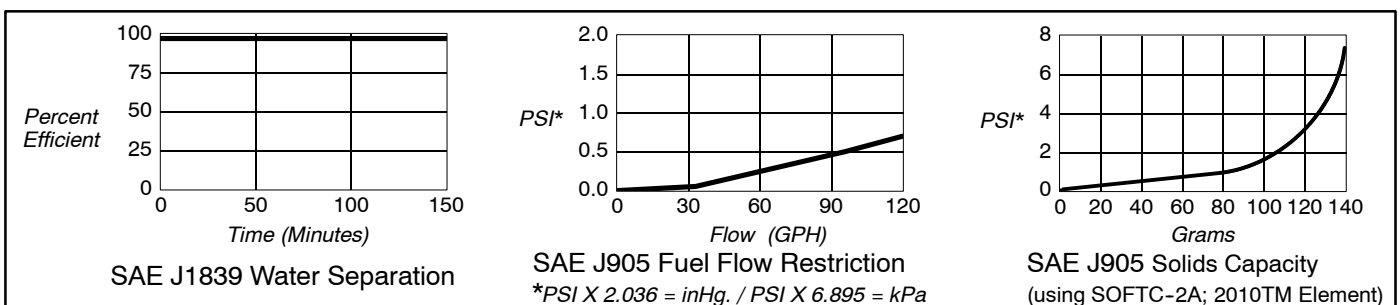
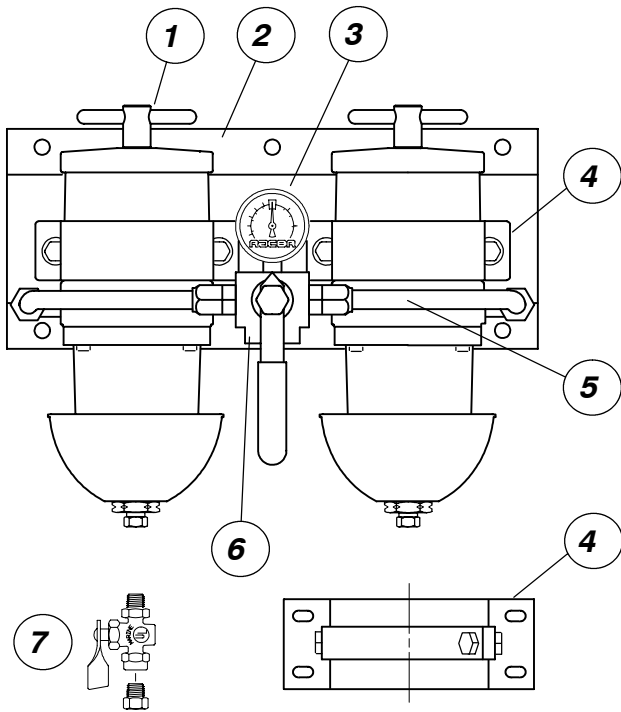

FIGURE 1. 75/500MAX Series. The circled number corresponds to the item number shown in the parts list below.



RK15300 Three-piece bracket

75/500MAX
Model shown

Item	Part No.	Description	Case Qty.
1	500MA	Shell. Refer to Model 500MA for a complete parts list	
2	RK15329	Main Bracket (will not accommodate piece body clamp brackets)	1
3	RK19476	Gauge Assembly	1
4	RK15378	Body Clamp Bracket, One-Piece	1
	RK15300	Body Clamp Bracket, Three-Piece (See illustration below)	1
5	RK15344	Rigid Tubing Assembly	1
6	RK15321	Valve Assembly	1
	RK15389	Valve Service Kit	1
7	RK19492	UL Listed Marine Drain Valve (order two for use with this unit)	1
	15350	Installation Instructions, 75/500MAX	

For Fuel Port Adapter Fittings, Water Detection Kits and Manifold Conversion Kits, see the Accessories Section.

For parts not listed, call Racor customer service: (800) 344-3286.

Marine Turbine Series

Model 75/900MAX

SPECIFICATIONS are found on *Turbine Series introduction page*.

How to Order -The example below illustrates how the part numbers are constructed.

75/900MAX	P	10
<u>Basic Model</u> 180 GPH Add 'M' for metal bowl Example: 75/900MAXM	<u>Water Probe.</u> ¹ Add 'P' for an in-bowl water probe. (Omit if not desired).	<u>Element Filtration Rating.</u> Specify one: '2' for 2 micron '10' for 10 micron or '30' for 30 micron
¹ Must be used with Water Detection Kit only. See Accessories Section.		

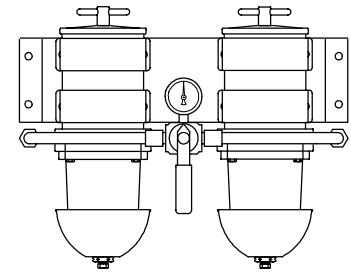

75/900MAX

Replacement Service Elements -Order two (2) per unit.
SERVICE ELEMENT INCLUDES LID SEAL AND T-HANDLE O-RING.

2040SM-OR	2 Micron (Brown end caps) <i>Recommended for Final /Secondary Filtration</i>
2040TM-OR	10 Micron (Blue end caps) <i>Recommended for Primary or Secondary Filtration</i>
2040PM-OR	30 Micron (Red end caps) <i>Recommended for Primary Filtration* Only.</i> <i>*A secondary/final filter is required downstream.</i>



Mounting Hole Pattern -Refer to *Turbine Series introduction page* for filter dimensions.

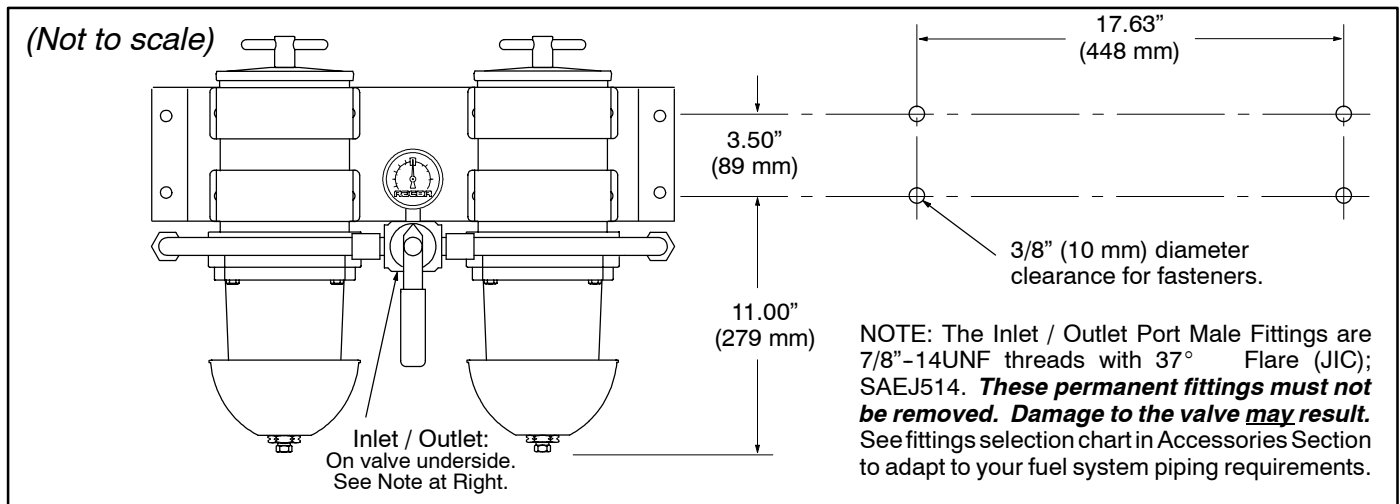

Performance Graphs -These results are from controlled laboratory tests. Filter results may vary by application.

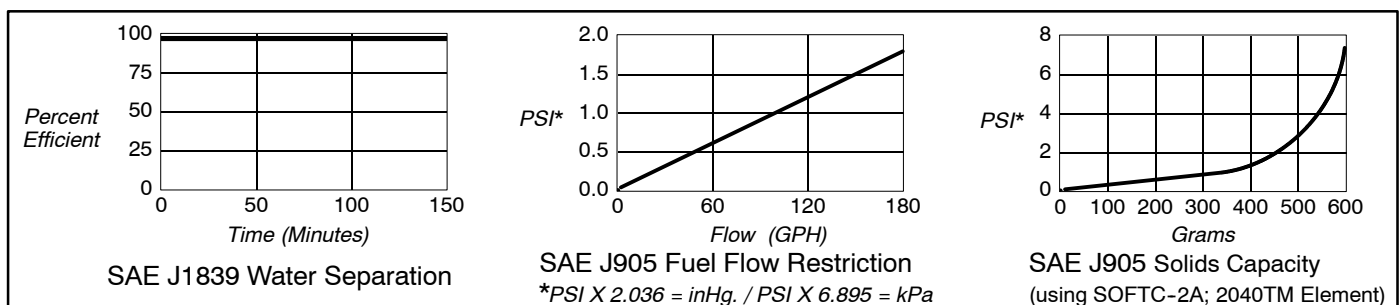
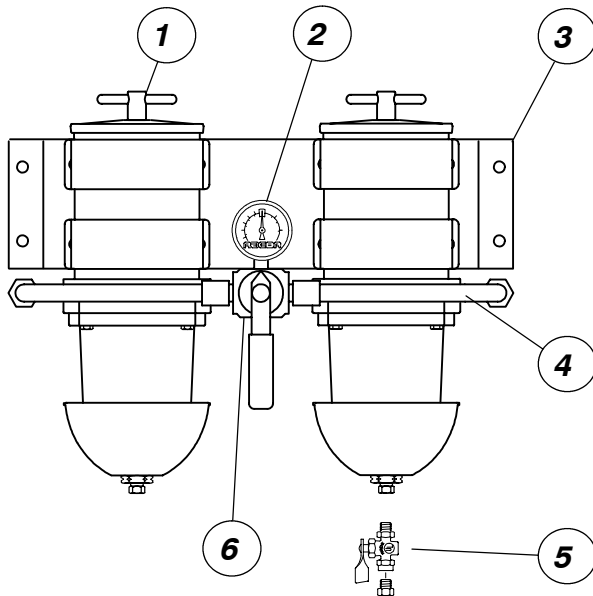

FIGURE 1. 75/900MAX Series. The circled number corresponds to the item number shown in the parts list below.



75/900MAX Model shown

Item	Part No.	Description	Case Qty.
1	900MA	Shell. Refer to Model 900MA for a complete parts list	
2	RK19476	Gauge Assembly	1
3	RK19486	Dual unit Bracket	1
4	RK19475	Rigid Tubing Assembly	1
5	RK19492	UL Listed Marine Drain Valve (order two for use with this unit)	1
6	RK19473	Valve Assembly	1
	RK19506	Valve Service Kit	1
	19485	Installation Instructions, 75/900MAX	

For Fuel Port Adapter Fittings, Water Detection Kits and Manifold Conversion Kits, see the Accessories Section.

For parts not listed, call Racor customer service: (800) 344-3286, 6 AM to 5 PM, Pacific Time.

Marine Turbine Series

Model 75/1000MAX

SPECIFICATIONS are found on Turbine Series introduction page.

How to Order -The example below illustrates how the part numbers are constructed.

75/1000MAX	P	10
<u>Basic Model</u> 360 GPH Add 'M' for metal bowl Example: 75/1000MAXM	<u>Water Probe.</u> ¹ Add 'P' for an in-bowl water probe. (Omit if not desired).	<u>Element Filtration Rating.</u> Specify one: '2' for 2 micron '10' for 10 micron or '30' for 30 micron
¹ Must be used with Water Detection Kit only. See Accessories Section.		

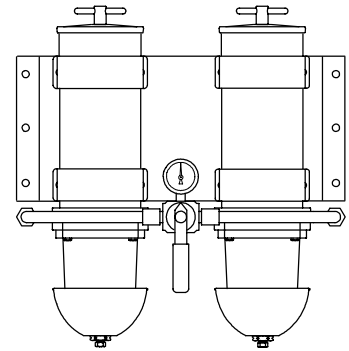

75/1000MAX

Replacement Service Elements -Order two (2) per unit.
SERVICE ELEMENT INCLUDES LID SEAL AND T-HANDLE O-RING.

2020SM-OR	2 Micron (Brown end caps) Recommended for Final /Secondary Filtration
2020TM-OR	10 Micron (Blue end caps) Recommended for Primary or Secondary Filtration
2020PM-OR	30 Micron (Red end caps) Recommended for Primary Filtration* Only. *A secondary/final filter is required downstream.



Mounting Hole Pattern -Refer to Turbine Series introduction page for filter dimensions.

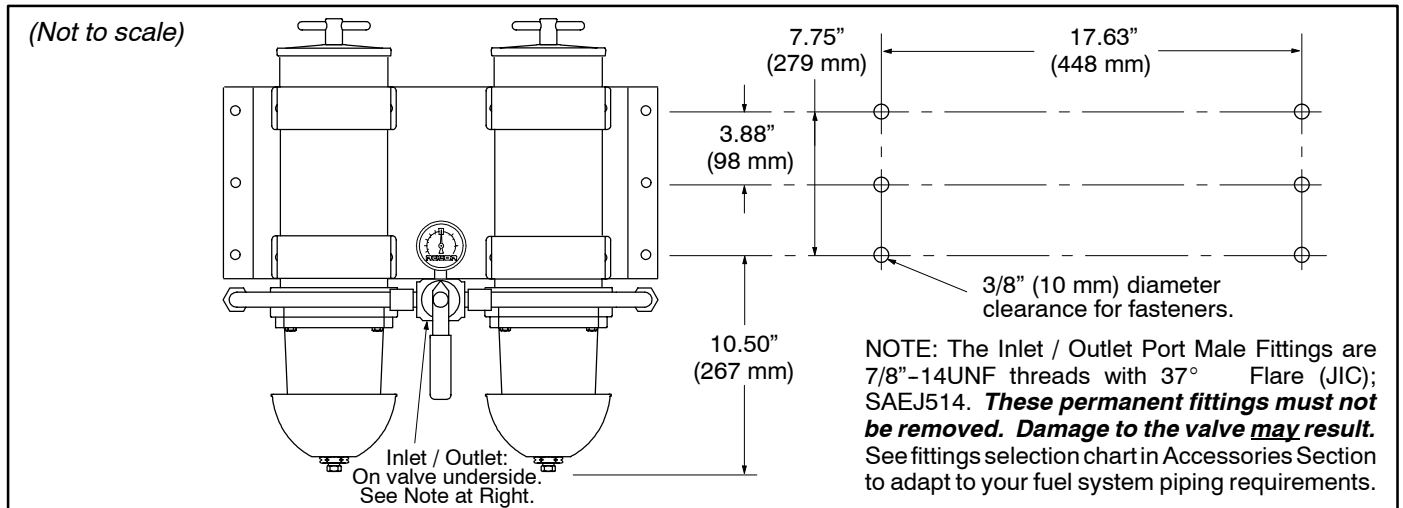

Performance Graphs -These results are from controlled laboratory tests. Field results may vary by application.

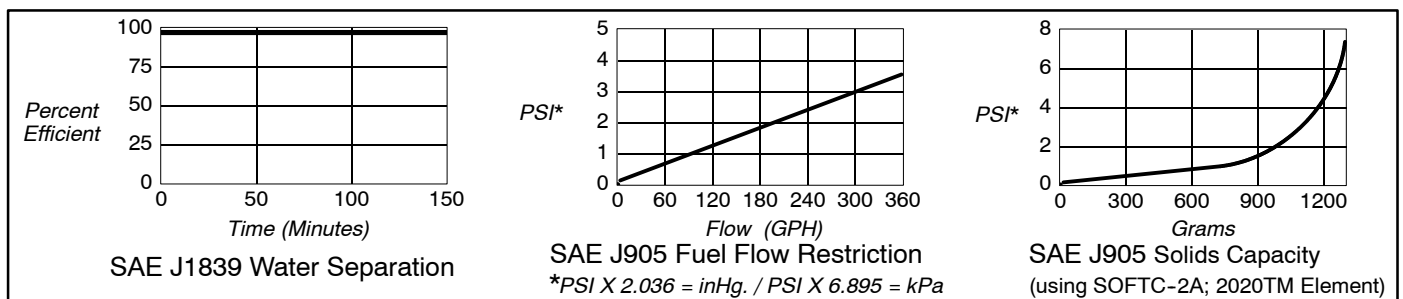
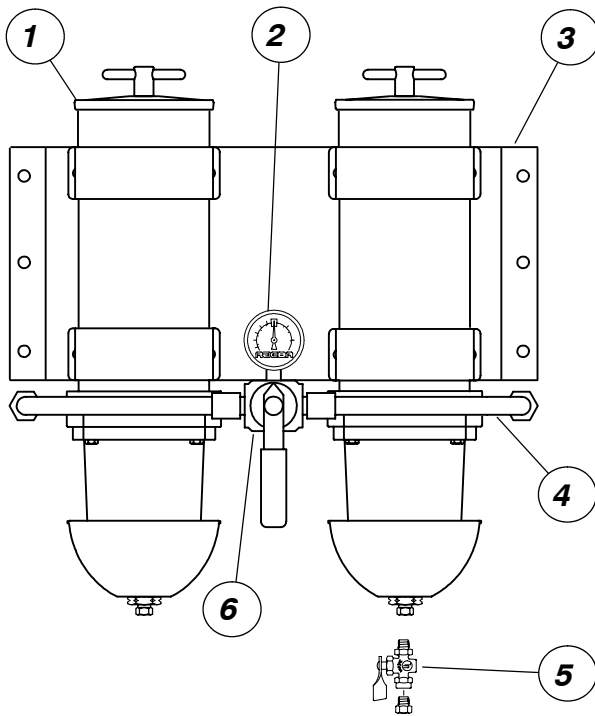

FIGURE 1. 75/1000MAX Series. The circled number corresponds to the item number shown in the parts list below.



75/1000MAX Model shown

Item	Part No.	Description	Case Qty.
1	1000MA	Shell. Refer to Model 1000MA for a complete parts list	
2	RK19476	Gauge Assembly	1
3	RK11-1777	Dual unit Bracket	1
4	RK19475	Rigid Tubing Assembly	1
5	RK19492	UL Listed Marine Drain Valve (order two for use with this unit)	1
6	RK19473	Valve Assembly	1
	RK19506	Valve Service Kit	1
	19485	Installation Instructions, 75/1000MAX	

For Fuel Port Adapter Fittings, Water Detection Kits and Manifold Conversion Kits, see the Accessories Section.

For parts not listed, call Racor customer service: (800) 344-3286, 6 AM to 5 PM, Pacific Time.

Marine Turbine Series

Model 77/1000MA

SPECIFICATIONS are found on Turbine Series introduction page.

How to Order -The example below illustrates how the part numbers are constructed.

77/1000MA	P	10
<u>Basic Model</u> 540 GPH Add 'M' for metal bowl Example: 77/1000MAM	<u>Water Probe.</u> ¹ Add 'P' for an in-bowl water probe. (Omit if not desired).	<u>Element Filtration Rating.</u> Specify one: '2' for 2 micron or '10' for 10 micron or '30' for 30 micron
¹ Must be used with Water Detection Kit only. See Accessories Section.		

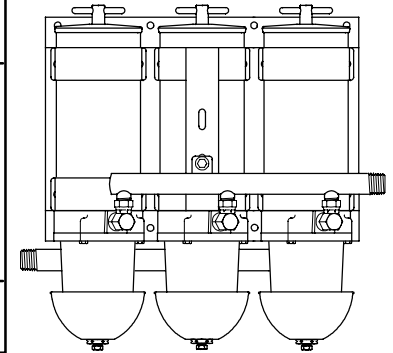

77/1000MA

Replacement Service Elements -Order three (3) per unit.
SERVICE ELEMENT INCLUDES LID SEAL AND T-HANDLE O-RING.

2020SM-OR	2 Micron (Brown end caps) Recommended for Final /Secondary Filtration
2020TM-OR	10 Micron (Blue end caps) Recommended for Primary or Secondary Filtration
2020PM-OR	30 Micron (Red end caps) Recommended for Primary Filtration* Only. *A secondary/final filter is required downstream.



Mounting Hole Pattern -Refer to Turbine Series introduction page for filter dimensions.

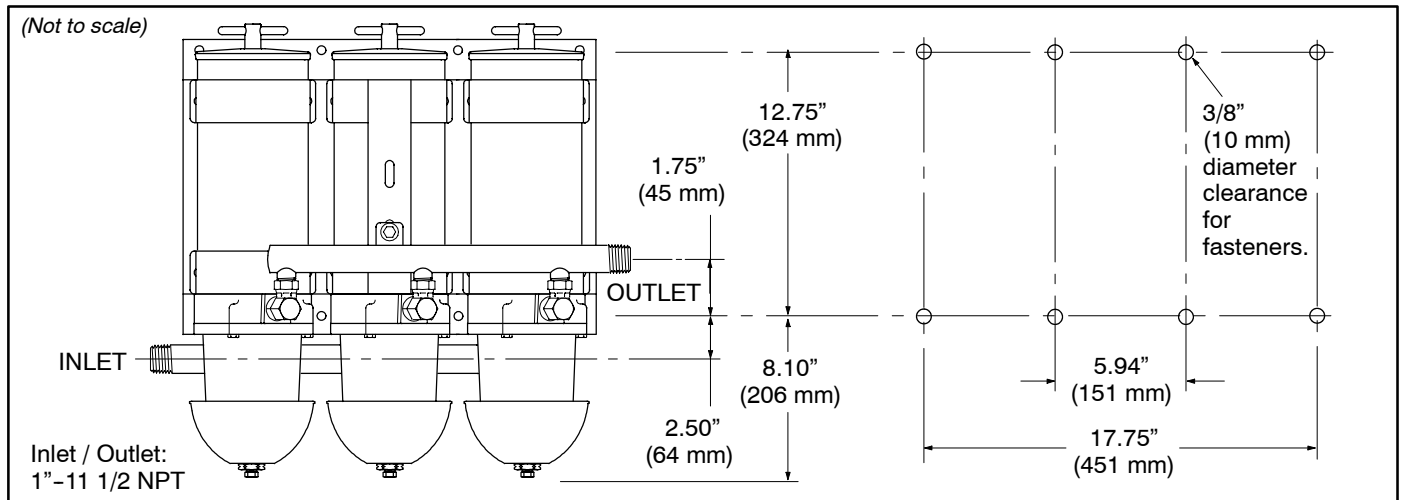

Performance Graphs -These results are from controlled laboratory tests. Field results may vary by application.

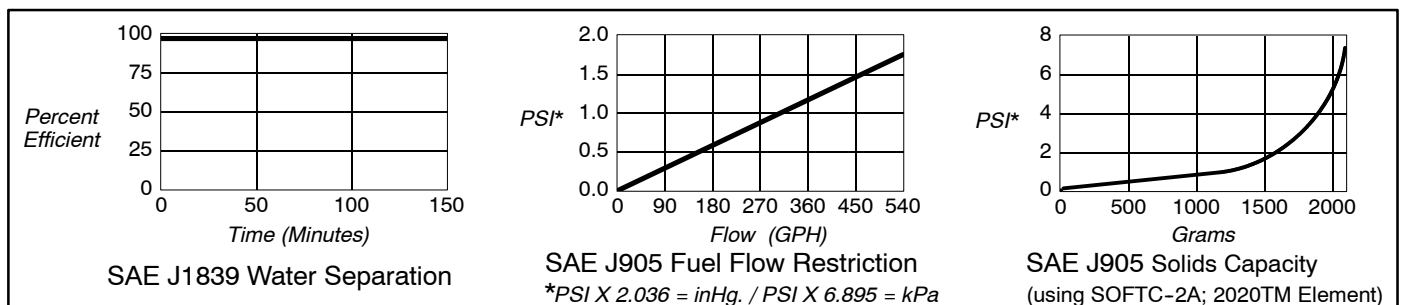
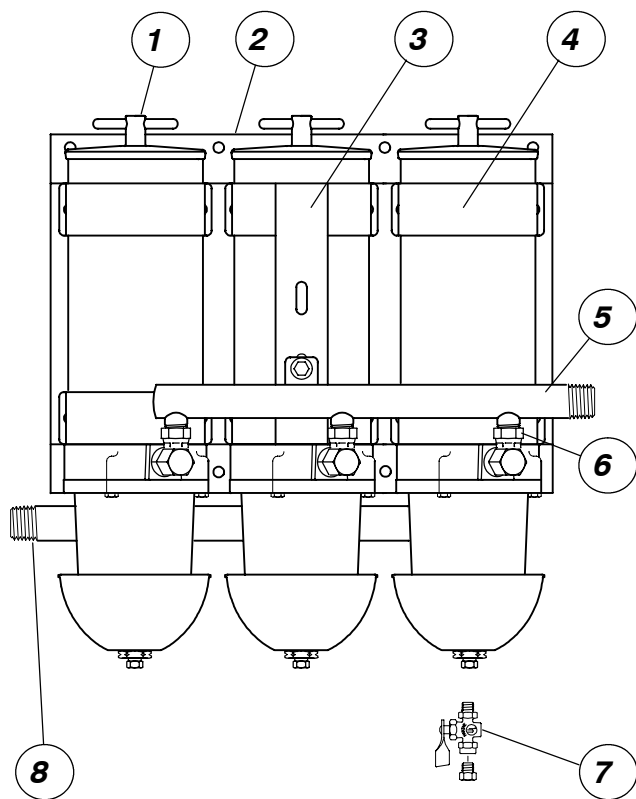

FIGURE 1. 77/1000MA Series. The circled number corresponds to the item number shown in the parts list below.



Item	Part No.	Description	Case Qty.
1	1000MA	Shell. Refer to Model 1000MA for a complete parts list	
2	11-1632	Triple unit Bracket	1
3	11895	Clamp Bracket Assembly	1
4	RK11895	Clamp Bracket	1
5	11902	Outlet Manifold	1
6	11072	Elbow Fitting, Parker #2507-10-8	1
7	RK19492	UL Listed Marine Drain Valve (order three for use with this unit)	1
8	11893	Inlet Manifold	1
	11-1831	Installation Instructions, 77/1000MA	

For Water Detection Kits and Manifold Conversion Kits, see the Accessories Section.

For parts not listed, call Racor customer service: (800) 344-3286, 6 AM to 5 PM, Pacific Time.

77/1000MA Model shown

Marine Turbine Series

Model 79/1000MAV

SPECIFICATIONS are found on Turbine Series introduction page.

How to Order -The example below illustrates how the part numbers are constructed.

79/1000MAV	P	10
<u>Basic Model</u> 540 GPH Add 'M' for metal bowl Example: 79/1000MAVM	<u>Water Probe.</u> ¹ Add 'P' for an in-bowl water probe. (Omit if not desired).	<u>Element Filtration Rating.</u> Specify one: '2' for 2 micron '10' for 10 micron or '30' for 30 micron
¹ For use with Water Detection Kit only. See Accessories Section.		

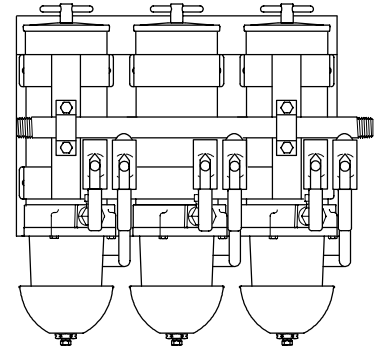

79/1000MAV

Replacement Service Elements -Order three (3) per unit.
SERVICE ELEMENT INCLUDES LID SEAL AND T-HANDLE O-RING.

- 2020SM-OR** 2 Micron (Brown end caps)
Recommended for Final /Secondary Filtration
- 2020TM-OR** 10 Micron (Blue end caps)
Recommended for Primary or Secondary Filtration
- 2020PM-OR** 30 Micron (Red end caps)
Recommended for Primary Filtration* Only.
*A secondary/final filter is required downstream.



Mounting Hole Pattern -Refer to Turbine Series introduction page for filter dimensions.

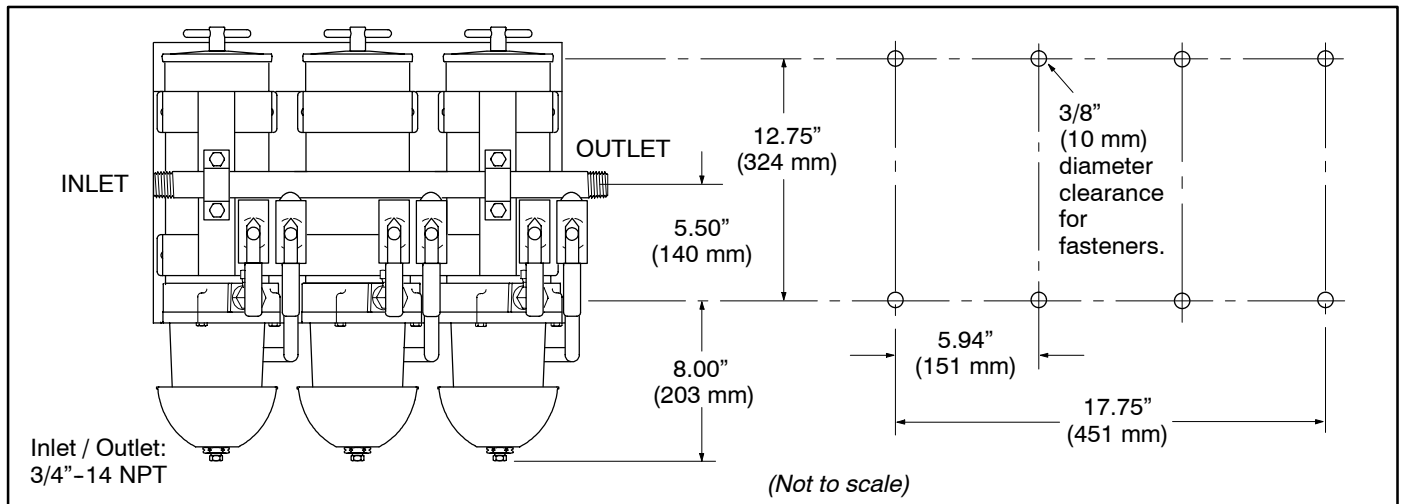

Performance Graphs -These results are from controlled laboratory tests. Field results may vary by application.

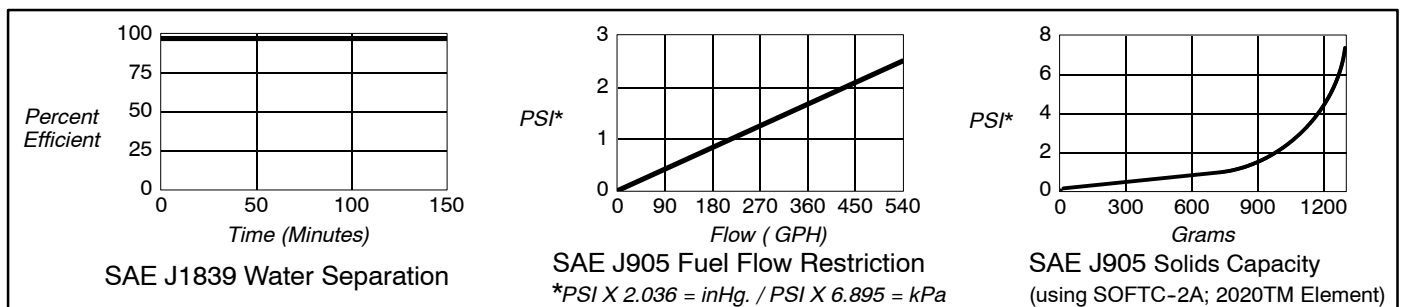
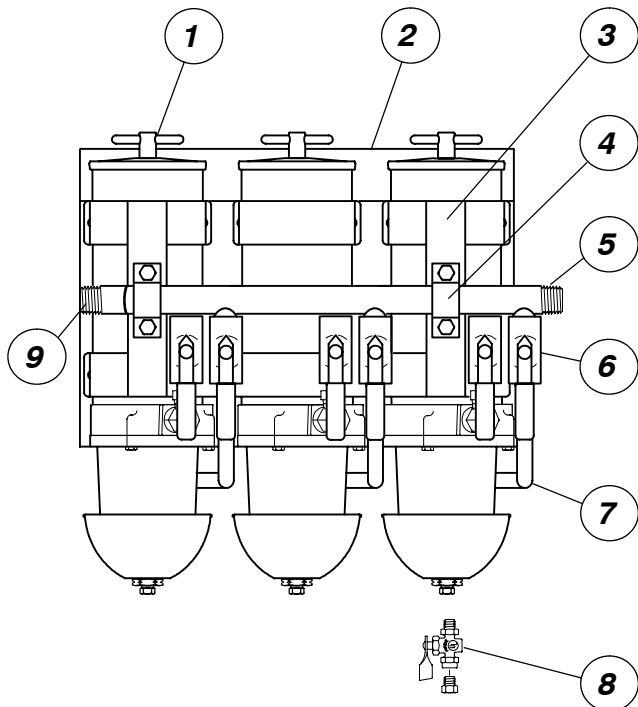

FIGURE 1. 79/1000MAV Series. The circled number corresponds to the item number shown in the parts list below.



Item	Part No.	Description	Case Qty.
1	1000MA	Shell. Refer to Model 1000MA for a complete parts list	
2	11-1632	Triple unit Bracket	1
3	11895	Clamp Bracket	1
4	11-1761	'U' Bracket	1
5	19461	Outlet Manifold	1
6	RK11073	1/2" Ball Valve	1
7	11-1626	Formed Tubing Assembly	1
8	RK19492	UL Listed Marine Drain Valve (order three for use with this unit)	1
9	19460	Inlet Manifold	1
	11-1821	Installation Instructions, 79/1000MAV	

For Water Detection Kits and Manifold Conversion Kits, see the Accessories Section.

For parts not listed, call Racor customer service: (800) 344-3286, 6 AM to 5 PM, Pacific Time.

79/1000MAV Model shown

Model Illustrations

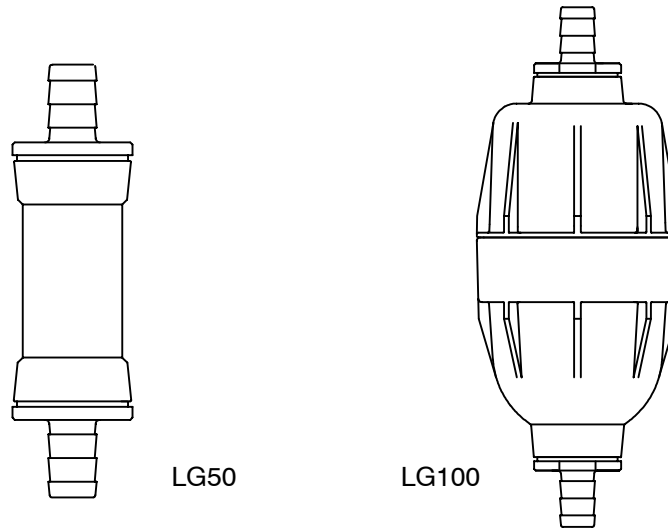

LG50

LG100

Selection Information

- GASOLINE** Model LG50 The fill flow rate capacity is 12 cubic feet (air) per minute (90 GPM) and can handle most commercial fuel dispensing nozzles. The vent line connections are for standard 5/8" I.D. rubber hose.
- DIESEL OR GASOLINE FUEL** Model LG100 The fill flow rate capacity is 17 cubic feet (air) per minute (127 GPM) and handles commercial fuel dispensing nozzles. The vent line connections are for standard 5/8" I.D. rubber hose.

Special Notes

- Exercise caution to avoid fuel splash if fueling nozzle is not equipped with automatic shut-off capability. Wrap an absorbant cloth around fill port/nozzle to ensure no spillage.
- Order Adapter Kit No. RK50033 (1/2"NPTF fittings) to accommodate all other vent line hose sizes.
- UL Listing pending, meets U.S.C.G. pleasure craft requirements.
- For additional information and availability, contact customer service at: (800) 344-3286, 6 AM to 5 PM, Pacific Time.

Specifications

BASIC MODELS	LG50	LG100
Fuel type	Gasoline	Diesel/Gasoline
Maximum Flow Capacity		
Cubic feet (air) per minute (CFM)	12	17
Gallons per minute (GPM)	90	127
Liters per minute (LPM)	341	481
Hose fitting size, I.D.	5/8"	5/8"
Optional adapter RK50033	1/2"NPTF	1/2"NPTF
Height		
in.	6	9 3/4
mm	152.4	247.7
Diameter		
in.	1 3/4	4
mm	44.5	101.6
Weight (dry)		
lbs.	1.2	1.62
kgs.	0.54	0.73
Operating Temperature	-40° / +255° F / -40° / +121° C	

SPECIFICATIONS are found on Fuel / Air Separator introduction page.

LG50 & LG100

LG50: 12 CFM, Gasoline.
LG100: 17 CFM Gasoline & Diesel Applications.
 Each unit includes standard 5/8" male hose barbs, hose clamps and instructions.

- FEATURES**
- Meets USCG pleasure craft requirements.
 - Allows fuel tank top-off without overboard spillage.
 - Prevents overboard spillage due to agitation.
 - Saves fuel costs and prevents possible fines.
 - Contains thermal expansion up to 2.4 PSI.
 - Prevents maintenance due to fuel stains on vessel.

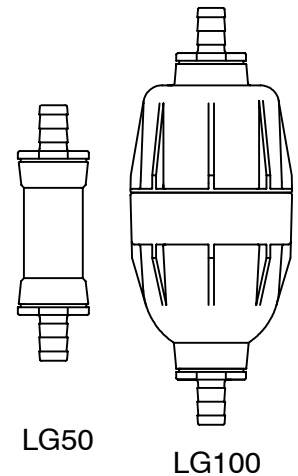

How the Lifeguard Works

LG50: 1. In the First Stage the venting tank fuel is diffused by the Flow Diverter. Air is allowed to bypass the diverter but fuel is directed back to the tank.

2. In the Second Stage, vapor collects on the interior surfaces and coalesces. The fuel returns downward by gravity and air continues up and out of the unit.

The Safety Relief Valve includes a floating check ball which will not permit a large in-rush of fuel to bypass. In the event of internal pressure reaching 2.4 PSI, the spring will compress and open the safety seat.

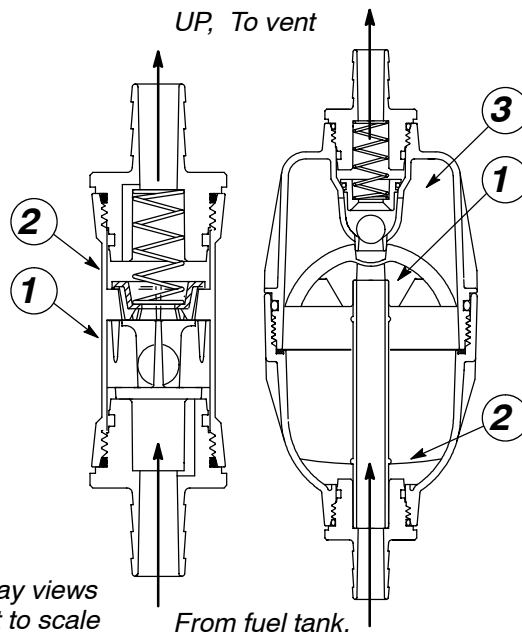

LG100: 1. In the First Stage the venting tank fuel is deflected by the Flow Diverter. Fuel is directed down to the drain ports and air is allowed to bypass and continue traveling up.

2. The Second Stage defoams the fuel through a fine wire mesh screen which filters out large contaminants. Under the screen, the fuel collects temporarily until it can flow back down to the fuel tank.

3. In the Third Stage, vapor collects on the interior surfaces and coalesces. The fuel returns downward by gravity and air continues up and out of the unit. The Safety Relief Valve includes a floating check ball which will not permit a large in-rush of fuel to bypass. In the event of internal pressure reaching 2.4 PSI, the spring will compress and open the safety seat.

General Information

The LG50 has no serviceable parts. See the Parts List below for fitting alternatives:

Part No.	Description	Qty.
RK50021	LG100 Replacement screen, spring, check ball & seals.	1
RK50023	LG100 2-piece Steel Mounting Bracket (not shown)	1
RK50033	Straight Fitting Adapter, 1/2" NPT female (not shown)	1
RK50003	Elbow Fitting, 5/8" hose barb (see view at right)	1

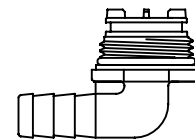

Note: Use only one elbow fitting with each unit as fitting orientation is random. (Two elbow fittings may not point to the directions you wish).

Troubleshooting

INSPECT FUEL SYSTEM COMPONENTS AND THE OVERBOARD VENT OF OBSTRUCTIONS, ANNUALLY.

These units must be installed vertically (or up to 60° from vertical) in the vent line with the arrow pointing UP (towards vent). Do not allow loops or low spots where fuel may pool. Flying insects may build nests in vent ports which may also obstruct the escaping vapors. These situations may be evident by premature tripping of the fuel nozzle automatic shut-off during refueling or constant fuel filling splash-ups.

In the event of severe fuel tank biological contamination, the units may be fouled and require inspection or cleaning. To disassemble, simply unthread the fittings from the housing and clean only in a fresh solvent bath. Coat the seals with motor oil and reassemble the unit in reverse order.

Model Illustrations

WFA12-S5, S30, S60

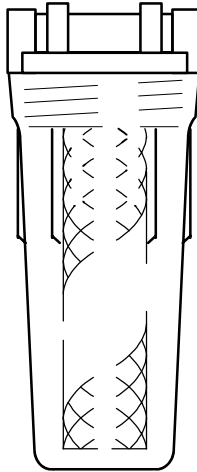

WFA12-T5

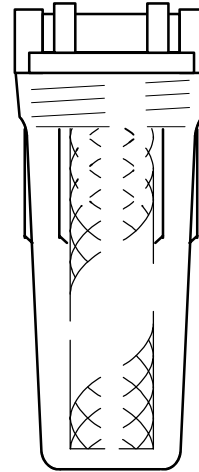

Selection Information

1. The Sediment Removal units can handle up to 6 GPM, 125 PSI and are available in 5, 30 and 60 micron filter ratings. *Five (5) micron elements trap fine particles, sixty (60) micron elements trap larger particles but have a longer life.*
2. The Taste and Odor Removal unit can handle up to 3 GPM, 125 PSI and is rated at 5 microns.

Special Notes

1. Sediment filters (WFA12-S5, S30 & S60) remove rust, sand, algae and other suspended solids.
2. The Taste and Odor filter (WFA12-T5) removes rust, sand, algae, suspended solids and also features an activated carbon core to remove contaminants which cause undesirable taste and odor.
3. Both units above feature the same housing. Only the filter element and unit label are different.
4. These units are for 'cold' drinking water filtration and are not intended to be used with 'hot' water, sea (salt) water, microbiologically unsafe water or water of unknown quality.
5. For additional information and availability, contact customer service at: (800) 344-3286, 6 AM to 5 PM, Pacific Time.

Specifications

BASIC MODELS	WFA12-S5, S30, S60	WFA12-T5
Fluid Filtered Filter Element	Drinking water WFC-S5, S30, S60	Drinking water WFC-T5
Maximum Flow Capacity		
Gallons per minute (GPM)	6	3
Liters per minute (LPM)	23	12
Maximum Pressure	125	125
Port Size, Inlet / Outlet	3/4"-14 NPTF	3/4"-14 NPTF
Height	12.50	12.50
	318	318
Diameter	5.25	5.25
	133.4	133.4
Weight (dry)	3.1	3.1
	1.4	1.4
Operating Temperature (cold water only)	+33° / +100° F / +0.6° / +38° C	

SPECIFICATIONS are found on Drinking Water Filter Series introduction page.

How to Order -The example below illustrates how the part numbers are constructed.

WFA12	-S30
For cold water filtration only. WFA12 is the basic model and includes mounting head, cartridge and transparent sump. Flow Rates: with T5 element: 3 GPM/180GPH, all others: 6 GPM/360 GPH.	<u>Filtration / Removal Type Rating.</u> Specify one: -T5 for 5 Micron / Taste & Odor. -S5 for 5 Micron / Sediment. -S30 for 30 Micron / Sediment. -S60 for 60 Micron / Sediment.

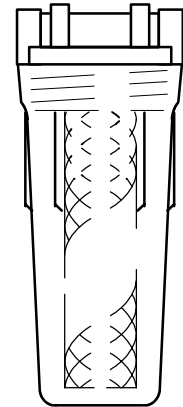

2

Replacement Cartridges -Service cartridges DO NOT include head seal.

WFC-T5	5 Micron, Taste and Odor Removal Cartridge
WFC-S5	5 Micron, Sediment Removal Cartridge
WFC-S30	30 Micron, Sediment Removal Cartridge
WFC-S60	60 Micron, Sediment Removal Cartridge

WFA12-T5
WFA12-S5
WFA12-S30
WFA12-S60

Mounting Hole Pattern -Refer to Drinking Water Filters introduction page for filter dimensions.

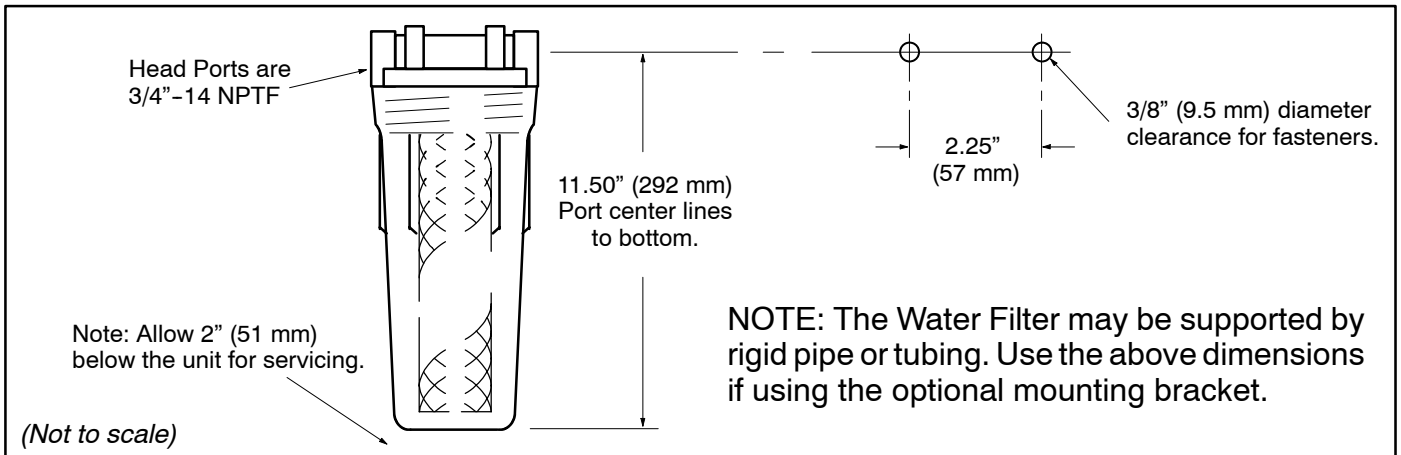

Parts List The circled number corresponds to the item number shown in the parts list below.

Item/Part No.	Description	Case Qty.
1. WFH12	Water Filter Head/Sump (new design)	6
2. WF-037	Head/Sump Seal (new design)	1
3. WFC-T5	5 Micron Taste and Odor Cartridge	20
WFC-S5	5 Micron Sediment Cartridge	20
WFC-S30	30 Micron Sediment Cartridge	20
WFC-S60	60 Micron Sediment Cartridge	20
4. WF-035	Optional Mounting Bracket Kit	1
5. WF-039	Optional Bowl Wrench (new design)	1
6. WF-010	Optional Bowl Wrench (old design)	1
7. WF-009	Head/Sump Seal (old design)	1

For parts not listed, call Racor customer service: 800/344-3286, PT.

Model Illustrations

Marine Air Filters/Silencers

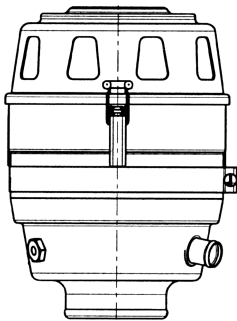

AF M408512

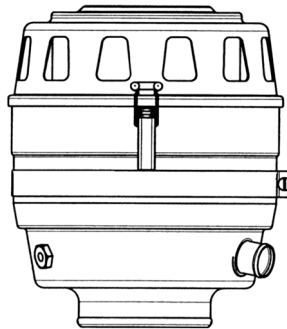

AF M501012

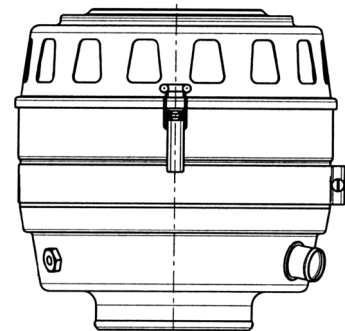

AF M601212

Special Notes

1. For additional information and availability, contact customer service at: (800) 344-3286, 6 AM to 5 PM, Pacific Time.

Specifications

BASIC MODELS		AF M408512	AF M501012	AF M601212
Max. Air Flow*	CFM L/s	800 377.6	1200 566.4	1600 755.2
Outlet Diameter	in. mm	4.00 101.6	5.00 127.0	6.00 152.4
Filter Element		AF M8040	AF M8050	AF M8060
Length	in. mm	12.50 317.5	12.50 317.5	12.50 317.5
Depth	in. mm	9.59 243.5	11.14 282.8	13.51 343.2
Hose Barb size	in. mm	1.00 25.4	1.25 25.4	1.25 31.75
Weight (dry)	Lbs. kgs.	4.16 1.89	5.03 2.28	8.00 3.63
Operating Temperature		-40° / +240° F / -40° / +116° C		
* Values given are cubic feet per minute (CFM) and liters per second (L/s).				

Marine Air Filtration

Marine Air Filters

Specifications are found on the Introduction page.

AF M408512

Replacement Element: AF M8040

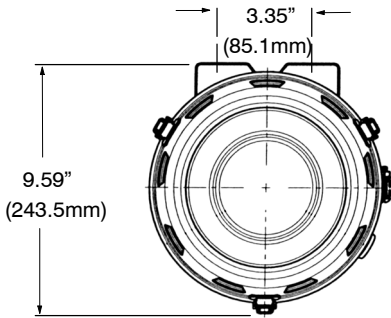

No Scale Top View

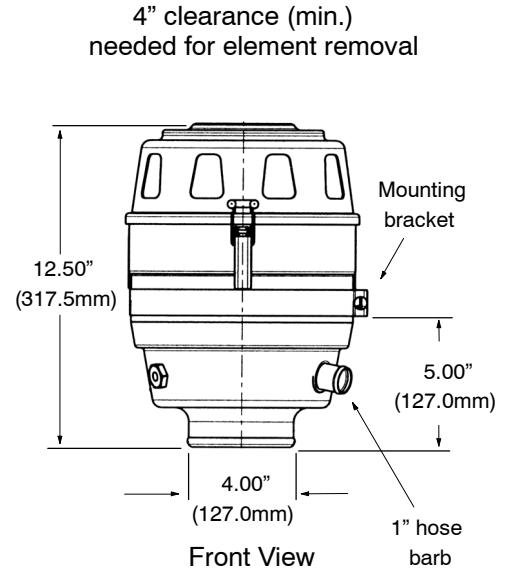
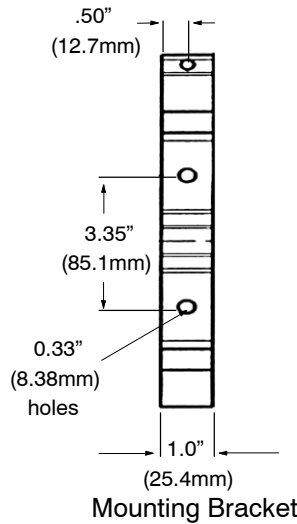

AF M501012

Replacement Element: AF M8050

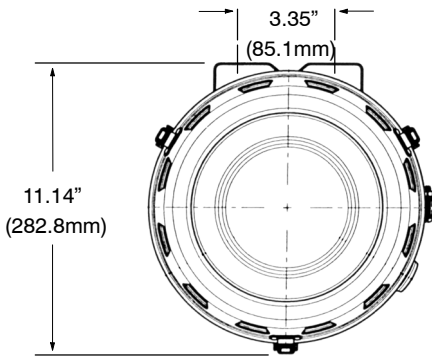

No Scale Top View

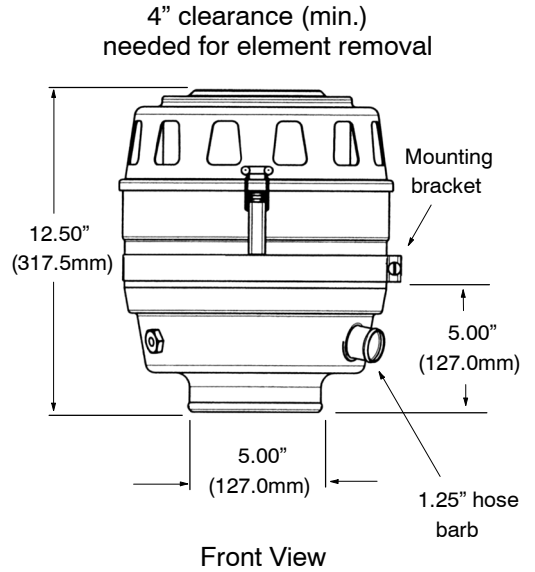
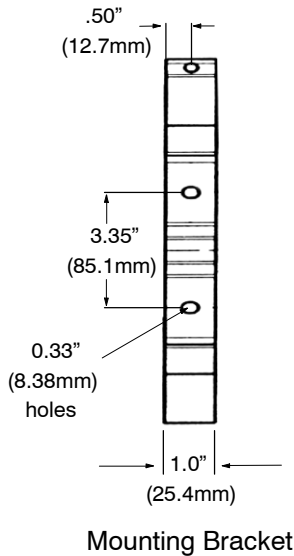

AF M601212

Replacement Element: AF M8060

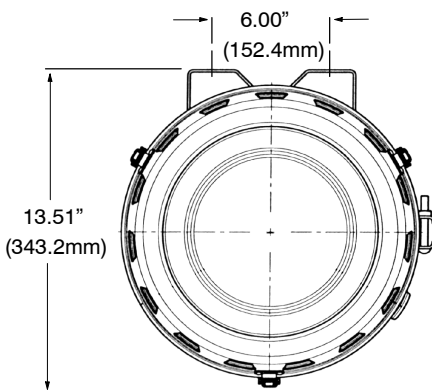

No Scale Top View

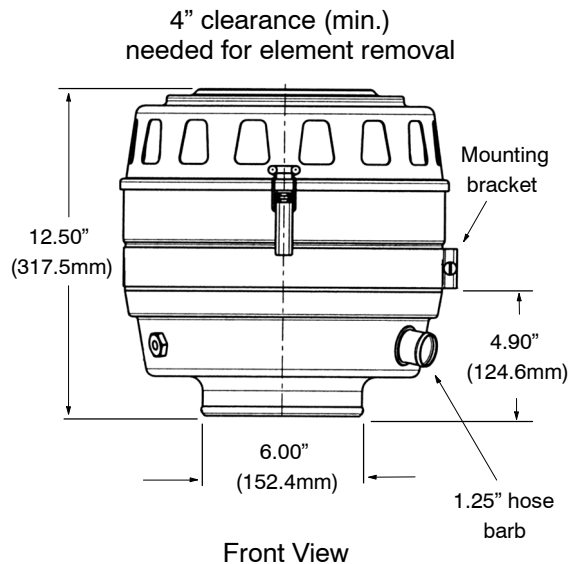
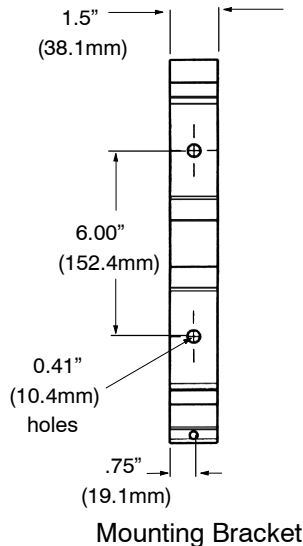

USCG-rated hose for gasoline, diesel, lube oil, and hydraulic systems for commercial and recreational applications.

How to Order:

CGH	- 5	- 50
USCG Accepted Hose	Number -5 -6 -8 -10 -12 -16 Hose I.D. size 1/4" 5/16" 13/16" 1/2" 5/8" 7/8"	Standard length is a 350 foot roll. Specify '-50' for a 50 foot roll.

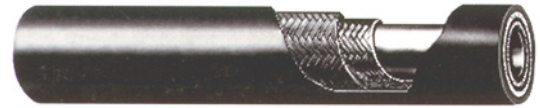

Specifications

Part Number	Hose I.D.		Hose O.D.		Working Pressure		Burst Pressure		Minimum Bend Radius		Weight		InHg	
	inch	mm	inch	mm	psi	MPa	psi	MPa	inch	mm	lbs/ft	kg/m	Inches of Hg	kPa (abs)
CGH-5	1/4	6.3	0.58	15	500	3,5	2000	14,0	1	25	0.19	0,28	20	33
CGH-6	5/16	8	0.68	17	500	3,5	2000	14,0	1 1/4	30	0.23	0,34	20	33
CGH-8	13/16	10	0.77	20	500	3,5	2000	14,0	1 3/4	45	0.28	0,42	20	33
CGH-10	1/2	12.5	0.92	23	500	3,5	2000	14,0	2 1/4	55	0.39	0,58	20	33
CGH-12	5/8	16	1.08	27	500	3,5	2000	14,0	2 3/4	70	0.47	0,70	20	33
CGH-16	7/8	22	1.23	31	500	3,5	2000	14,0	3 1/2	90	0.41	0,61	20	33

Racor marine hose for fuel, oil, and hydraulic fluids is fire resistant and meets SAE J1527 Type A class and SAE J1942 standards. This hose delivers test-proven performance in a wide operating temperature range, constant working pressure in popular sizes, long-lasting reinforced construction, kink and cut resistance, and compatibility with a variety of standard 100R5 fittings.

Construction

Fuel and oil-resistant synthetic rubber tube with one braid of high-tensile steel wire, and a weather and fire resistant synthetic blue rubber cover. The layline is embossed for permanent identification.

No Skive

1. Assembly of No-Skive hose and fittings does not require removal of outer cover of hose. This eliminates premature hose failure caused by skiving too long or short and protects vulnerable wire wrap during fitting assembly.
2. Cushion grip increases hose life - supporting cushion of compressed rubber between gripping threads on fitting reduces wire movement, minimizing stress.
3. Corrosion protection - steel wire braid of No-Skive hose is never exposed because outer rubber cover is not removed before assembling fitting.
4. No-Skive fittings are designed to allow socket threads to penetrate outer cover of hose and grip the wire braid of the hose.
5. Simple two step assembly - attached socket to hose, thread nipple to socket.

Application and Temperature Range



Low pressure service hose for use with gasoline, ethanol blends, diesel fuels, petroleum-base hydraulic fluids and lubricating oils within a temperature range of -4°F to 212°F (-20°C to 100°C). Water, water/glycol and water/oil emulsion hydraulic fluids up to 185°F (85°C). Meets Class 1 permeation requirements with gasoline and gasoline/ethanol blends, and passed a 2 1/2 minute fire test. USCG accepted for commercial and recreational vessel applications.

Hose Fittings

Part Number	Hose Size	Part Number	Hose Size
20820-5-5	SAE-5	20820-8-8	SAE-8
20820-6-6	SAE-6	20820-10-10	SAE-10

Plated Steel Fuel Port Fittings are now available - see the following page.

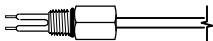
Water Probe & Detection Kits -Not for use with gasoline applications.

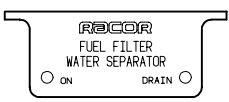
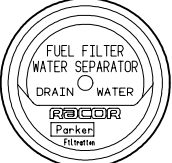
Kit Part No.	Description / Notes	Use with:	Qty.	
RK21069	Water Probe Kit, 1 each.	For all models with Heat shield or metal bowl	1	 RK21069
RK30880	Water Probe with Built-in 12 or 24vdc Detection Electronics and Connector Kit Includes underdash warning light kit. UL. Approved for use with diesel only.	For all models except 500MA & 500MAP	1	 RK30880
RK20725	Underdash mount Water Detection Module. 12 vdc, light only. Probe not included	For all models	1	 RK20725
RK20726	2" Gauge Water Detection Module. 12 or 24 vdc, light and audio. Probe not included.	For all models	1	 RK20726
RK30056	2" Gauge Water Detection Module (RK20726) and Water Probe (RK21069)	For all models with water sensor port in bowl	1	
RK30743	2" Gauge Water Detection Module (RK20726) and Water Probe (RK21069) and Metal Bowl.	For Engine Spin-on Series	1	

Vacuum / Compound Gauge Kits

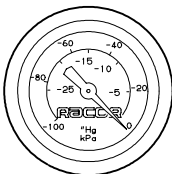
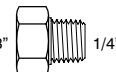
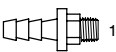
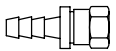
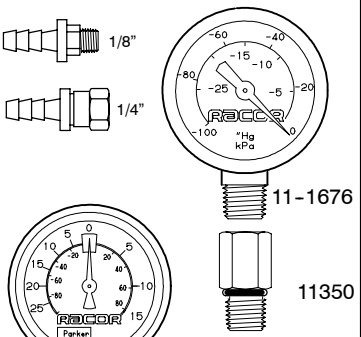
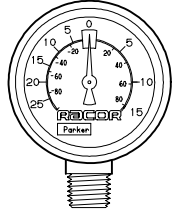
Kit Part No.	Description / Notes	Use with:	Qty.	
1606B	Vacuum 0-30 Hg. 2" dial Silicone dampened with 1/4"NPT back mount. For instrument panel installation. #4 hose not included. ¹	For vacuum applications	1	 1606B
0102-4-2	Adapter fitting, straight 1/4"NPTM X 1/8"NPTF	7232-4/7234-4	1	
7232-4	Adapter fitting, 1/8"NPTM X #4 hose ¹	0102-4-2	1	
7234-4	Adapter fitting, 1/4"swivel X #4 hose ¹	For all gauges	1	
RK11-1669	'T-Handle' Replacement Vacuum Gauge Kit. Includes Silicone dampened gauge (11-1676) 0-30 inHg., lid fitting (11-1668) and O-ring (11350). Replaces original 'T'-Handle.	For vacuum applications	1	 11-1676 11350 11-1668
RK19476	Compound Vacuum 0-25/ Pressure 0-15. 2" dial. 1/4"NPT bottom mount. UL Approved replacement.	MAX / all applications	1	 RK19476

¹ Rubber hose is suitable for 15 feet or less, otherwise rigid plastic tubing is recommended to obtain accurate readings.

Diesel Shut-off Drain Valve Kit -Underwriters Laboratories Marine Listed / USCG Accepted.

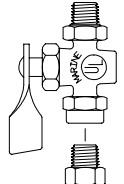
Kit Part No.	Description / Notes	Use with:	Qty.	
RK19492	Diesel Marine Shut-off Valve Kit. All brass construction. Features 1/4"NPTM to bowl or adapter with a 1/4"NPTF bottom port for use with provided 1/4"NPTM plug. (Plug must be in valve unless servicing).	For all diesel applications	1	 RK19492

Racor Products

Section 3 Recycling & High Flow

- Selection
- Introduction
- 800D-5REC
- 8250D
- 812
- 75812
- 79812
- 850
- 800D-OF3



Help & General
Information

SELECTION - SECTION 3

DIESEL FUEL FILTERING / RECYCLING / BLENDING:

1. Find the location: Portable or Stationary Mount Models.

2. Find the installation. Will the unit be installed on the suction (vacuum) or pressure side of a fuel pump? Racor units are most efficient when installed on the suction side of a fuel pump. The Recycling systems are intended for suction installations however the Model 850 may be used for pressure installations up to 150 PSI.

3. What other conditions apply?

Water contamination is a problem. An in-unit water sensing detector should be added to inform the operator of a rapid build-up of water and necessary servicing. These are available for most units. Some models have automatic water draining features. Use with Diesel applications, only.

Is the unit intended to service a fleet of vehicles? The portable 800D-5REC is recommended for fleet use.

With the above information, review the models suggested that best fit your installation. Most of the Model Groups have addition information to help in identifying the exact model for your needs.

Call your Racor distributor or Racor Customer Service if you need additional assistance at (209) 521-7860 or (800) 344-3286, 6:00 AM to 5:00 PM, Pacific Time.

FUEL FILTERING / OIL BLENDING SYSTEMS:

1. Go directly to the Fuel Filtering / Blending units for specific selection information.

HYDRAULIC FILTERING SYSTEMS:

1. Go directly to the Hydraulic Filtering System Section for specific selection information.

Selection Information

DIESEL FUELS ONLY

General

The filter/recycler units in this section remove water and solid contamination from diesel fuel ensuring clean contaminant free fuel for a variety of applications.

The 800D-OF3 and 810D-OF3 filter/blender units in this section not only remove water and solid contamination from diesel fuel but also provide fleet operators with a steady supply of FREE diesel fuel by blending waste engine lube oil at a 20:1 ratio (5%) with the diesel fuel. Every gallon of waste engine lube oil now becomes a gallon of no-cost diesel fuel and at the same time solves a major environmental problem - the disposal of the waste oil. *These models blend oil-to-fuel automatically.*

1. SUCTION OR PRESSURE SIDE INSTALLATION?

Below ground reservoirs

Do not exceed 10 feet of lift or 10-12 inHg. of inlet piping restriction. Use the following formula to calculate restriction in inHg. (inches of mercury).

LIFT FEET X .78 = RESTRICTION IN inHg.

Above ground reservoirs

Up to 5 psi of head pressure is acceptable for the 800D-20.

Up to 10 psi of head pressure is acceptable for the 800D-12

For head pressures greater than 10 psi, but not more than 150 psi, the model 850 should be specified. Use the following formula to calculate head pressure.

HEAD FEET X .38 = HEAD PRESSURE IN PSI.

2. DETERMINE THE FUEL FLOW RATE REQUIRED (If applicable).

Selection should be made by considering the primary use for the unit.

For fuel dispensing pumps up to 4 gallons per minute, the 8250D may be 'hard piped' into the delivery system. For higher dispenser rates, other units may be selected.

Recycling/filtering the fuel in storage tanks cleans the fuel while removing particulates and sediment accumulations. The fuel may be recycled numerous times, depending on the severity of contamination. Filter/recycling clock times can be reduced by selecting a larger capacity unit.

Severely contaminated tanks may require more than one 'cycle' to clean them properly. For example, the 812 filters up to 720 gallons per hour or 12 gallons per minute. It would take about 8 1/2 minutes to filter 100 gallons. To cycle the tank 3 times would take about 26 minutes.

3. STATIONARY MOUNT OR PORTABLE?

Stationary units may be secured to a service area and are intended for permanent hook-up to the fuel source. The portable 800D-5REC may be taken wherever filter/recycling is needed.

Using this information, select a unit from the following page index which exceeds the maximum fuel flow demand and fits within installation size limitations (if any).

Go directly to the 800D-OF3 / 810D-OF3 page for information on the Fuel/Oil Blender.

Model Illustrations

Not to scale

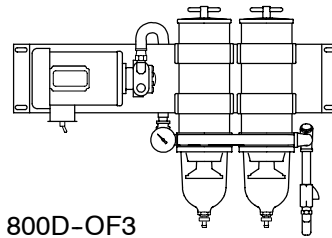

800D-OF3

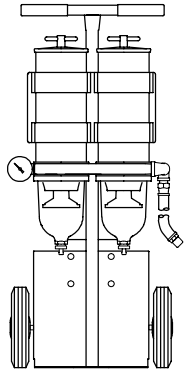

800D-5REC

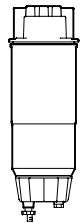

8250D

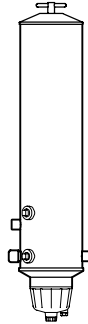

812

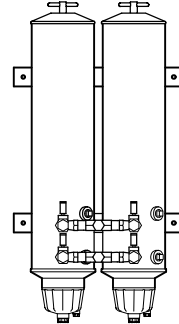

75812

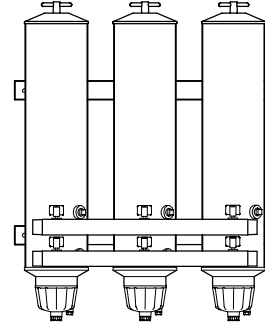

79812

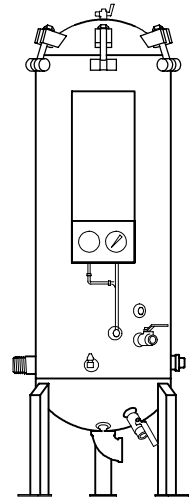

850

3

Special Notes

1. See individual product information sheet for motor specifications, options and information.
2. For additional information and availability, contact customer service at: (800) 344-3286, 6 AM to 5 PM, Pacific Time.

Specifications

BASIC MODELS	800D-5REC	8250D	812	75812	79812	850	800D-OF3 810D-OF3
Function or Application	Filter/ Recycler	Dispenser/ Filter	Filter/ Recycler	Filter/ Recycler	Filter/ Recycler	Filter/ Recycler	Blender/ Recycler
Maximum Flow Rate	GPH / LPH 180 / 681	250 / 946	720 / 2725	1440 / 5450	2160 / 8175	3000/11355	180 / 681
Maximum Working Pressure	PSI/kPa N/A	15 / 103	30 / 207	30 / 207	30 / 207	150 / 1034	N/A
Service Filter Element Number required / unit	2020TM-OR 2	S3207 1	8021 / 8022 1 each	8021 / 8022 2 each	8021 / 8022 3 each	See 850 detail page	2020TM-OR 2
Port Sizes	1/2" NPT	1 1/4" NPT	1" NPT	1" NPT	1 1/4" NPT	1 1/2" NPT	1/2" NPT
Height	in / mm 46 / 1168	16 / 411	34 / 855	34 / 855	34 / 855	51 / 1295	46 / 1168
Width	in / mm 20 / 508	5.3 / 135	8.9 / 226	18 / 476	30 / 762	20 / 508	20 / 508
Depth	in / mm 24 / 610	5.3 / 135	9 / 229	16 / 394	16 / 394	21 / 533	24 / 610
Weight (dry)	Lbs./ kgs. 82 / 37	3.1 / 1.4	22 / 10	77 / 35	160 / 73	230 / 104	57 / 26
Clean Pressure Drop	PSI / kPa 1.5 / 10.2	1.0 / 6.9	3.2 / 22	6.0 / 41.4	5.2 / 35.9	3.0 / 20.1	1.2 / 8.5
Bowl / Sump Water Capacity	610 ml	82 ml	3.7 L	7.4 L	11.1 L	24 L	610 ml
Operating Temperature	-10° to + 180°F / -23° to + 82°C						

Recycler / Filtration Systems

Model 800D-5REC

SPECIFICATIONS are found on introduction page.

How to Order

800D-5REC

- Portable Recirculating or Fuel Transfer unit.
- 180 GPH maximum flow rate.
- Power requirements: 120 Volts AC / 60 Hertz.
- Hoses are 5/8" I.D., 15 feet long.
- Vacuum/pressure gauge for monitoring element condition.
- Uses two (2) 2020TM filter elements.

Replacement Service Element

SERVICE ELEMENT INCLUDES LID SEAL.

2020TM-OR 10 Micron (Blue end caps)
The 800D-5REC uses two (2) elements

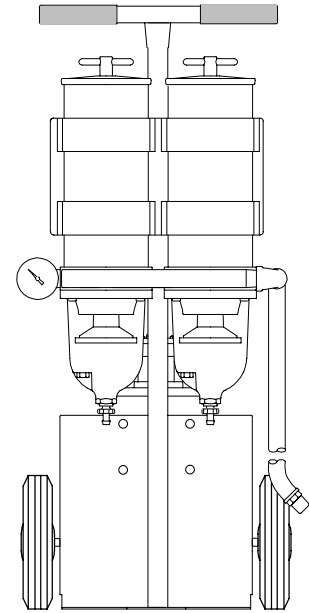

800D-5REC

Parts List

Item/Part No.	Description	Qty.
1 1000FG10	FF/WS *	2
2 RK18-1104	Compound gauge	1
3 RK 11892	Double manifold	2
4 RK18-1291	Mixer valve assembly	1
5 RK 11643	Motor / pump coupling	1
6 RK 18043	110/220 60 Hz motor 3 gpm pump	1
7244	Installation Instructions	

* See Section One - Turbine Series for parts.

Performance Graphs -Results are from controlled laboratory tests. Field results may vary by application.

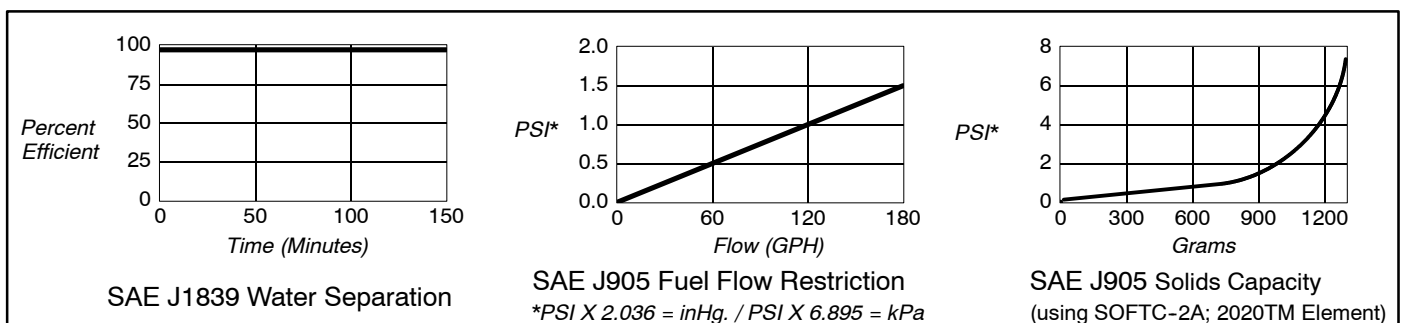

SPECIFICATIONS are found on the introduction page.

How to Order

8250D	Features
Basic Model 250 GPH. Call factory for available micron ratings and options not listed.	The 8250D is standard with 1 1/4" - 11 1/2 NPT (SAEJ476) ports, a 10 micron element and a see-thru bowl. The in-line head is designed for applications that do not require a mounting bracket.

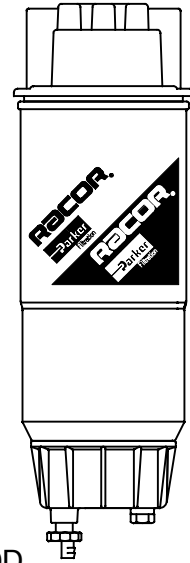

8250D

3

Replacement Service Element -6/Case. Service Element Includes Top and Bowl Seals.

S3207	10 Micron -For primary / secondary filtration
--------------	---

Parts List - The circled number corresponds to the item number shown in the parts list below.

Head top view.
Fuel ports are:
1 1/4" NPT (SAEJ476)

Item/Part No.	Description	Qty.
1	RK30368 8250 Head, 1-1/4" NPT Ports	1
2	RK30817 Port Plug, 1/4"NPT	10
3	S3207 10 micron Replacement Element	6
4	RK30965 Bowl / Element Gasket	10
5	RK30063 See-thru Bowl/Drain/Plug Assy.	1
6	RK30900 Bowl Assy. & 12 vdc Heater	1
7	RK20126 Plastic Water Sensor Plug, SAE	1
	RK21069 Water Probe	1
	30476 Drain Valve Knob	10
	22099 Drain Valve Seal	10
	31580 Installation Instructions, 8250D	

Performance Graphs -These results are from controlled laboratory tests. Field results may vary.

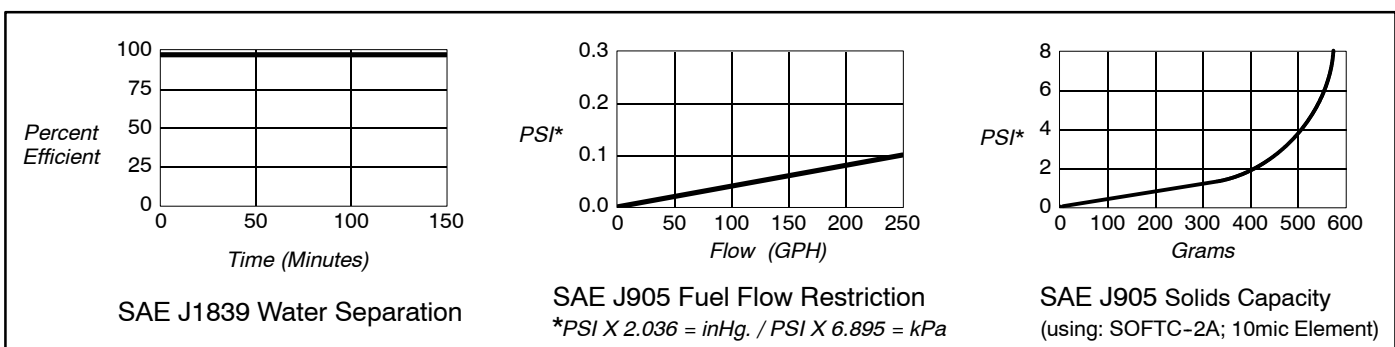

SPECIFICATIONS are found on System introduction page.

812	Features
<p><u>Basic Model</u> 720 GPH / 2725 LPH Stationary Fuel Filter / Water Separator that uses two standard Racor replacement elements. Installation is on the suction side of the pump for maximum efficiency and filter life.</p>	<ul style="list-style-type: none"> - Inlet/outlet ports: 1" - 11 1/2 NPTF - Rugged steel housing with two mounting brackets, with protective epoxy coating. - Removeable steel lid with T-handle for easy element access and fuel priming. - See-thru collection bowl allows quick visual inspection.

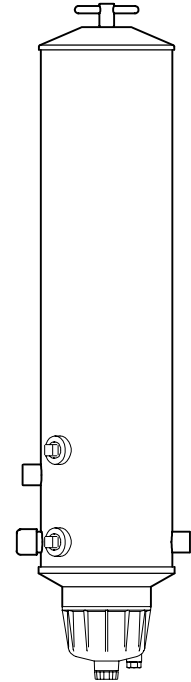

Replacement Service Elements -Order one (1) kit per unit.
SERVICE ELEMENT KIT INCLUDES LID SEAL.

RK22610 Element Kit. Includes (1) 40 Micron Filter (upper position) and (1) Coalescing Filter (lower position)

Parts List

Overhead clearance required for element removal: 12" / 305mm.

TOP VIEW

INLET 1" NPTF MALE

OUTLET 1" NPTF MALE

(Not to scale)

Item/Part No.	Description	Qty.
1 RK22682	T-Handle/Lid Assembly	1
2 RK22609	Lid Gasket	1
3 RK22610	Element Kit. (1)8021, (1)8022 and Includes Lid Gasket	1
4 RK11036	Bowl O-Ring	1
5 RK16017-01	Bowl Assembly	1
6 RK30058	Drain Valve Assembly	1
RK21069*	Water Probe (Option)	1
RK30880	Electronic Water Probe (Option)	1
22586	812 Installation Instructions	

**Must be used with a Water Detection Module.*

For parts not shown, call Racor customer service: (800) 344-3286, 6 AM to 5 PM, Pacific Time.

Performance Graphs -Results are from controlled laboratory tests. Field results may vary by application.

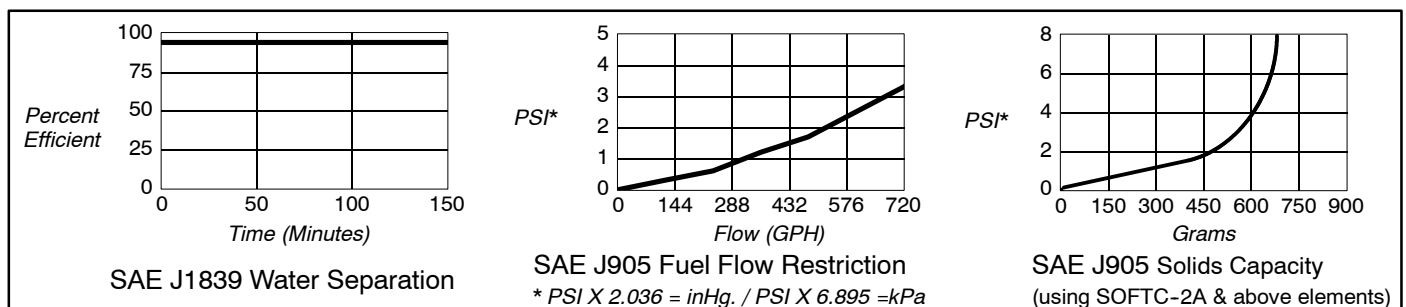

SPECIFICATIONS are found on System introduction page.

75812	Features
<p>Basic Model: 1440 GPH / 5450 LPH Duplex, stationary fuel filter / water separator. Includes isolator ball valves for servicing while engine is running.</p>	<ul style="list-style-type: none"> - Inlet/outlet ports: 1" - 11 1/2 NPTF - Rugged steel housing with two mounting brackets, with protective epoxy coating. - Removeable steel lid with T-handle for easy element access and fuel priming. - See-thru collection bowl allows quick visual inspection.

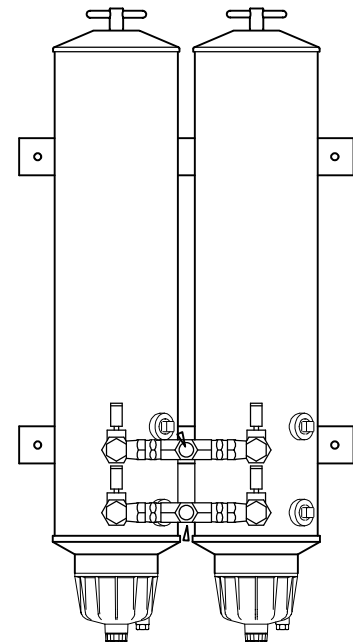

Replacement Service Elements -Order two (2) kits per unit.
 SERVICE ELEMENT KIT INCLUDES LID SEAL.

RK22610 Element Kit. Includes (1) 40 Micron Filter (upper position) and (1) Coalescing Filter (lower position)

Mounting Bolt Pattern -See Model 812 for available parts.

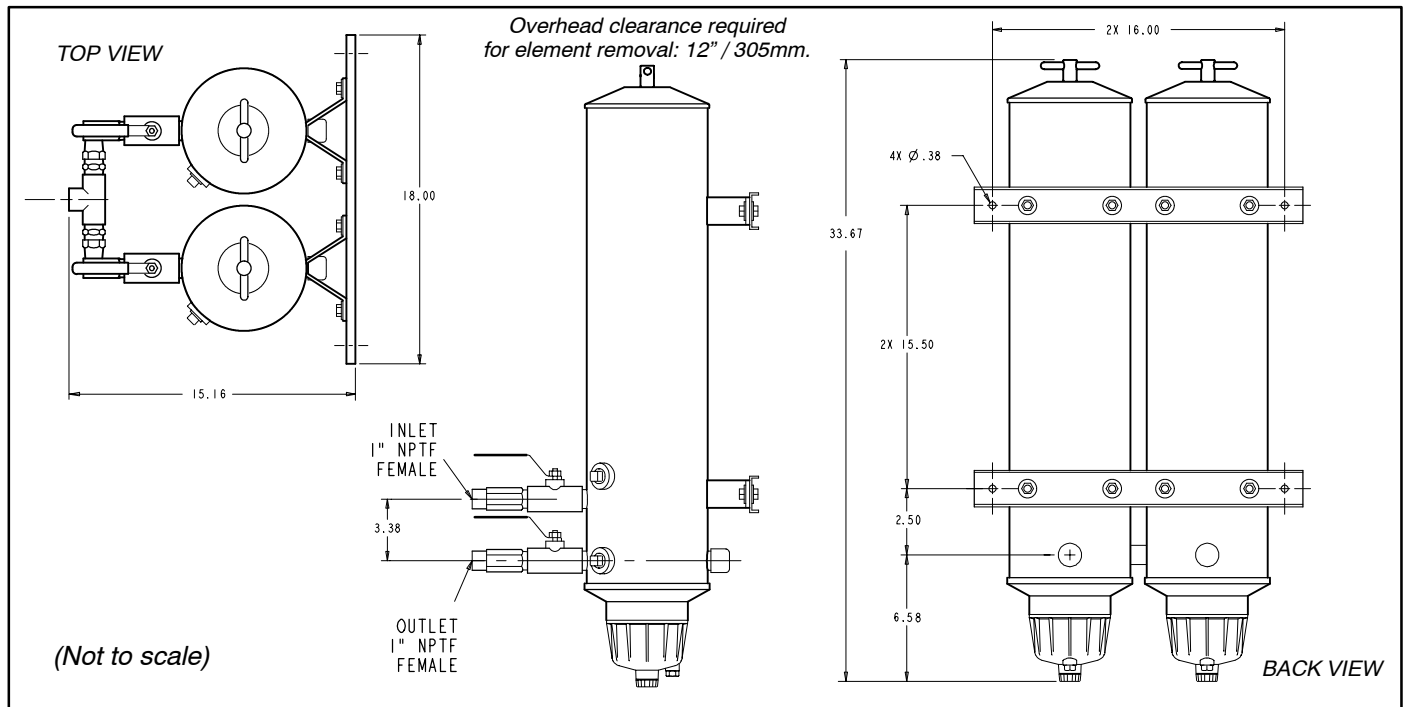

Performance Graphs -Results are from controlled laboratory tests. Field results may vary by application.

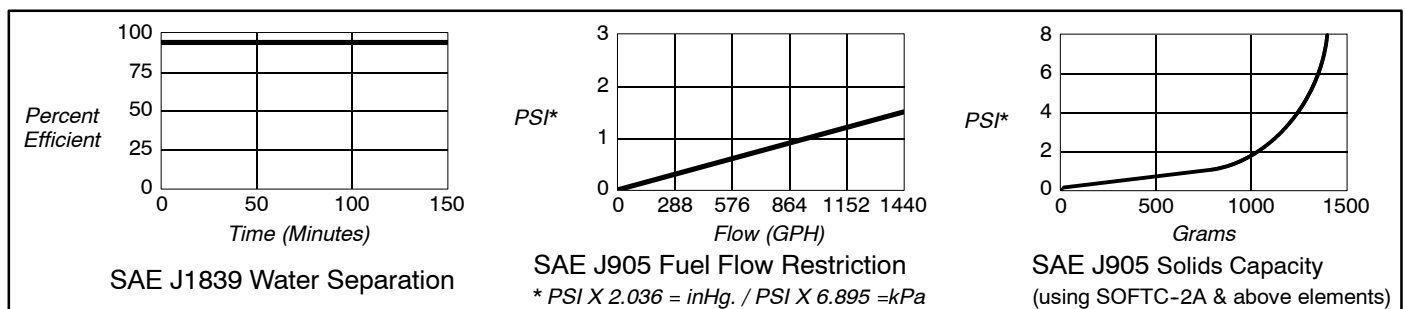

SPECIFICATIONS are found on System introduction page.

79812	Features
<p>Basic Model: 2160 GPH / 8175 LPH Triplex, stationary fuel filter / water separator. Includes isolator ball valves for servicing while engine is running.</p>	<ul style="list-style-type: none"> - Inlet/outlet ports: 1 1/4" - 11 1/2 NPTF - Rugged steel housing with two mounting brackets, with protective epoxy coating. - Removeable steel lid with T-handle for easy element access and fuel priming. - See-thru collection bowl allows quick visual inspection.

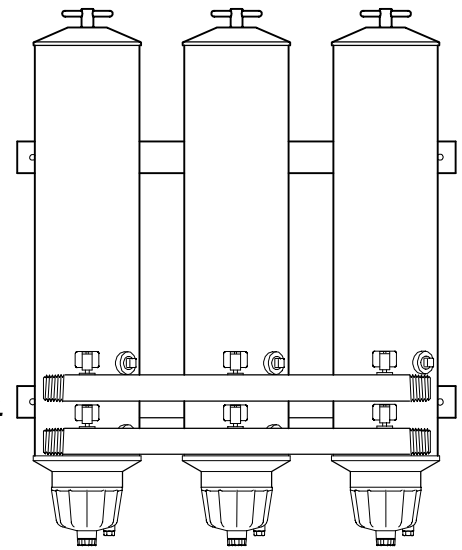

Replacement Service Elements -Order three (3) kits per unit.
SERVICE ELEMENT KIT INCLUDES LID SEAL.

RK22610 Element Kit. Includes (1) 40 Micron Filter (upper position) and (1) Coalescing Filter (lower position)

Mounting Bolt Pattern -See Model 812 for available parts.

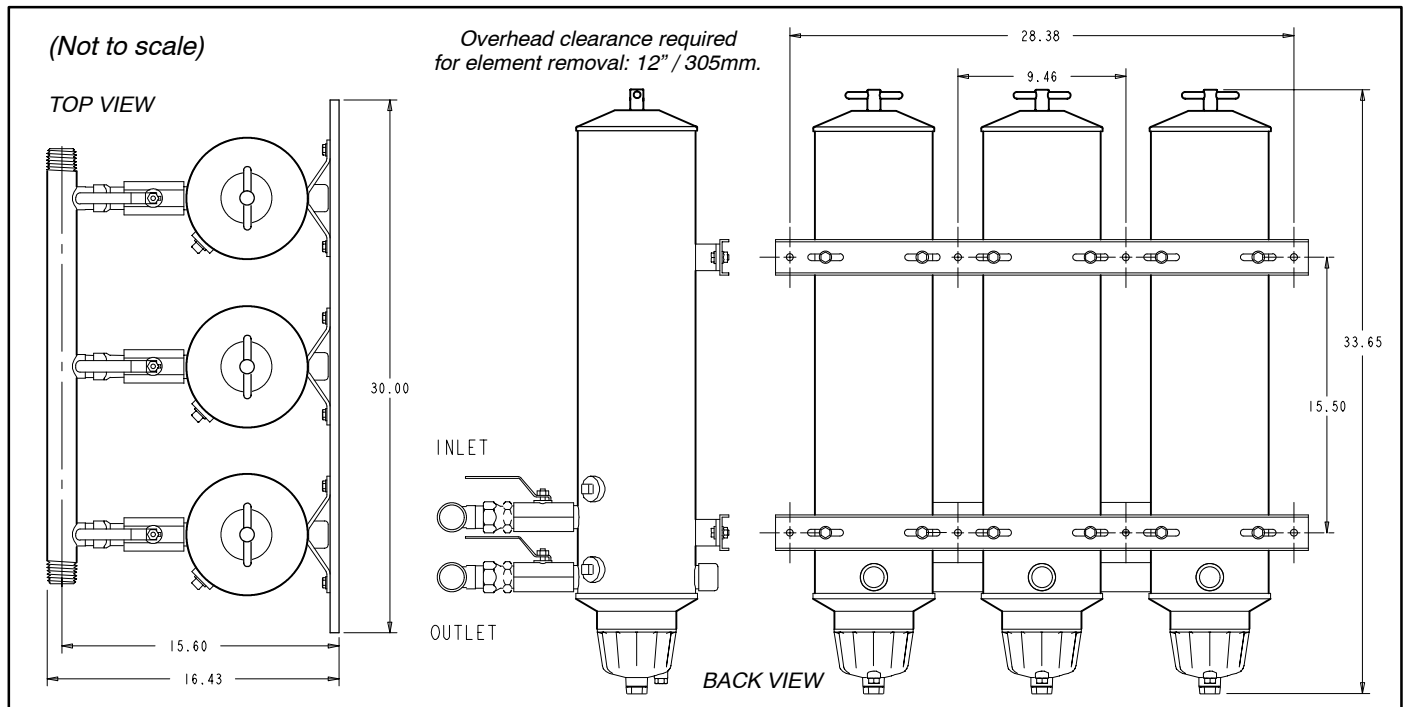

Performance Graphs -Results are from controlled laboratory tests. Field results may vary by application.

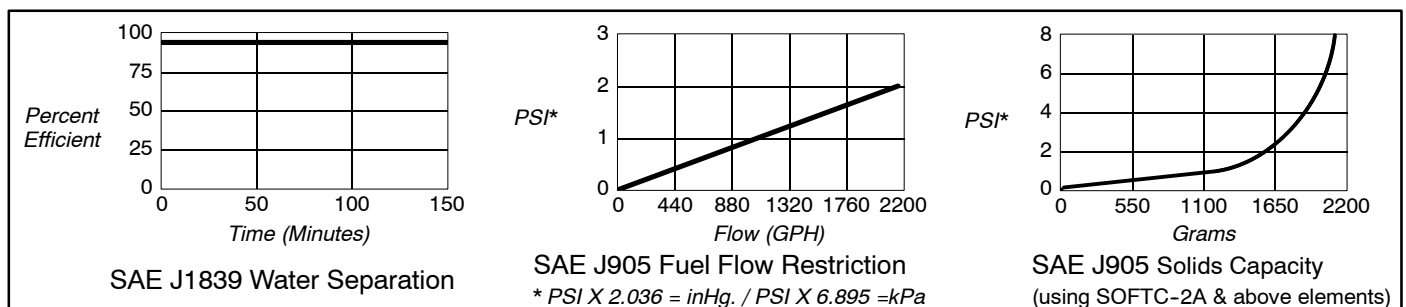

SPECIFICATIONS are found on System introduction page.

How to Order -The example below illustrates how the part numbers are constructed.

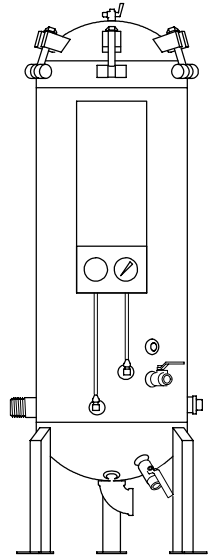

3

850	WS
<u>Basic Model</u>	<u>Options</u>
3000 GPH	'MD' Basic model with manual drains
Constructed to A S M E guidelines.	'WS' Manual Drain and Water Probe
Water sight ports and two manual drain valves are standard.	'H' Manual Drain and 1000 watt Heater
	'WSH' Manual Drain, Water Probe and Heater
	'SG' Manual Drain and Switch/gauge
	'SGWS' Manual Drain, Water Probe and Switch/gauge
	'SGWSH' Manual Drain, Water Probe, Heater and Switch/gauge
	'AD' 110 VAC Automatic Drain, Water Probe and Switch/gauge

Replacement Service Elements -Service elements **DO NOT** include the tank O-ring. See parts list.

The 850 typically uses 7 '8021' 40 micron filtration elements (upper) and 7 '8022' coalescing elements (lower).

RK8023S/CM Includes (7) 8021 40 micron elements and (7) 8022 Coalescing elements.

RK18-1669 Includes (14) 8021 40 micron elements.

RK18-1683 Includes (7) 8022 Coalescing elements and (7) dual-stage 10/40 micron elements.

Mounting Hole Pattern / Parts List

23" (584 mm) overhead clearance required for element removal.

Top View
(Not to scale)
Bolt Pattern

17.13" (435 mm) 5/8" fastener bolt circle. Three spaced 120° apart.

Inlet: 1 1/2"NPT

Outlet: 1 1/2"NPT

Item/Part No.	Description	Qty.
1 RK18-1441	O-Ring, 14" diameter	1
2 18-1369	Pressure Relief Valve	1
3 RK20726	Water Detector Gauge	1
4 RK18-1422	Pressure Gauge	1
5 RK18-1371	Sight Plug	1
6 RK18-1454	Water Probe	1
18-1392	Installation Instructions	

For parts not listed, call Racor customer service:
(800) 344-3286, 6 AM to 5 PM, Pacific Time.

Performance Graphs -Results are from controlled laboratory tests. Field results may vary by application.

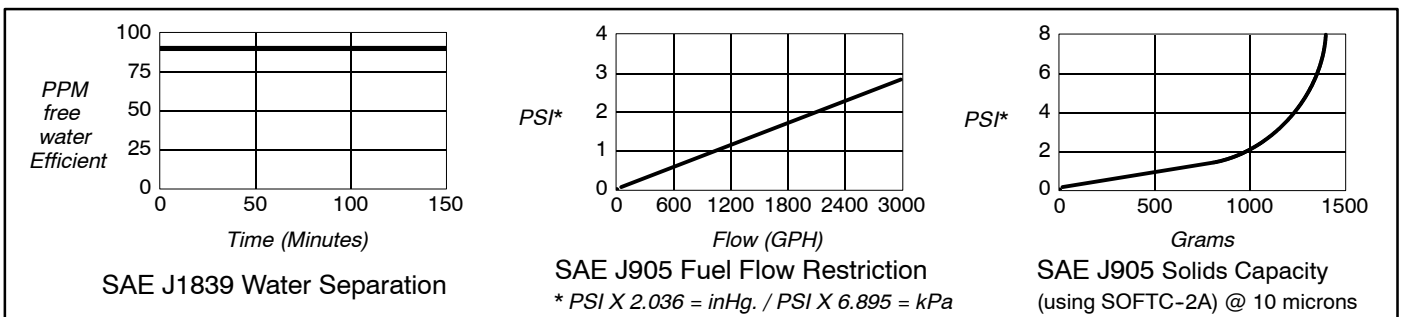

Blender / Filtration Systems

Model 800D-OF3

SPECIFICATIONS are found on Introduction page.

How to Order -The example below illustrates how the part numbers are constructed.

800D-OF3	D
Recycler/Blenders: 180 GPH	Motor Voltage: Specify one.
800D-OF3: VAC Model.	'A' 12 VDC
Specify one voltage from D to G.	'B' 24 VDC
810D-OF3: VDC Model.	'D' 100 VAC / 60 Hz
Specify one voltage: A or B.	'E' 110 VAC / 50 Hz
	'F' 220 VAC / 60 Hz
	'G' 220 VAC / 50 Hz

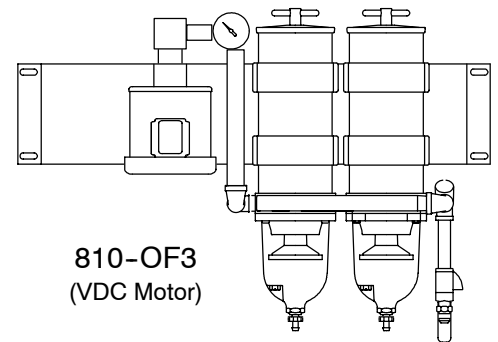
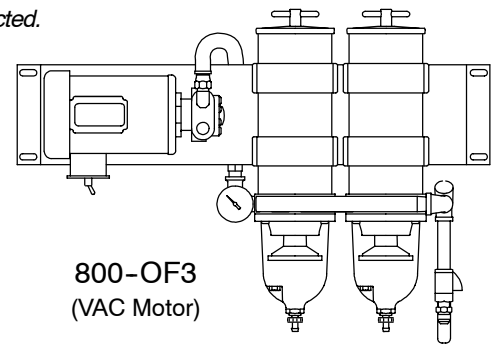

Replacement Service Elements

SERVICE ELEMENTS INCLUDE LID SEALS.

2020TM-OR 10 Micron (Blue end caps)
These models use two (2) elements

Mounting Hole Pattern / Parts List

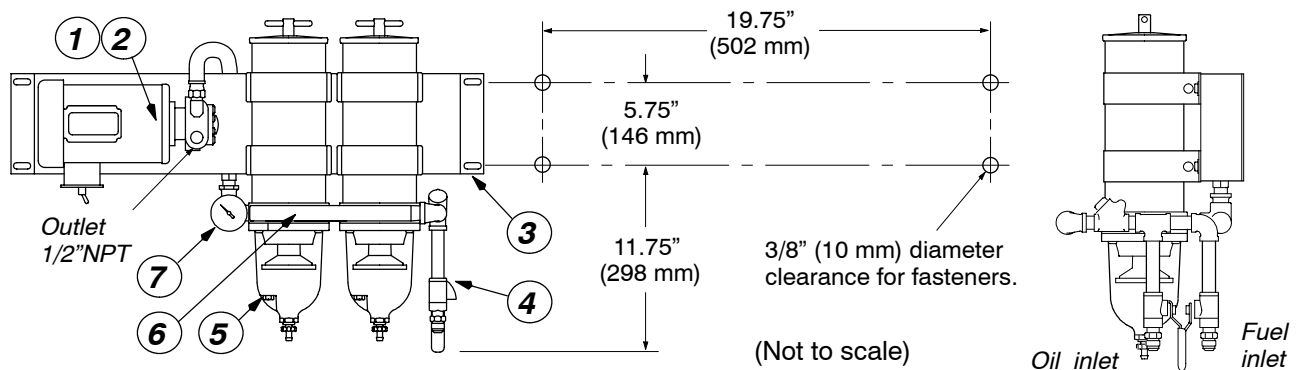

Item/Part No.	Description	Qty.	Item/Part No.	Description	Qty.
1 RK11643	Motor / pump coupling	1	4 RK18-1291	Mixer valve assembly	1
2 RK18043	110/220 60 Hz motor/3 gpm pump	1	5 1000FG10	FF/WS *	2
RK18544	110/220 50 Hz motor/3 gpm pump	1	6 RK11892	Double manifold	2
RK18-1144	12 VDC motor/3 gpm pump	1	7 RK18-1104	Compound gauge	1
RK18-1145	24 VDC motor/3 gpm pump	1	7245	Installation Instructions	
3 RK18999	Main mounting bracket	1	* See Section One - Turbine Series for parts listing.		

Performance Graphs -Results are from controlled laboratory tests. Field results may vary by application.

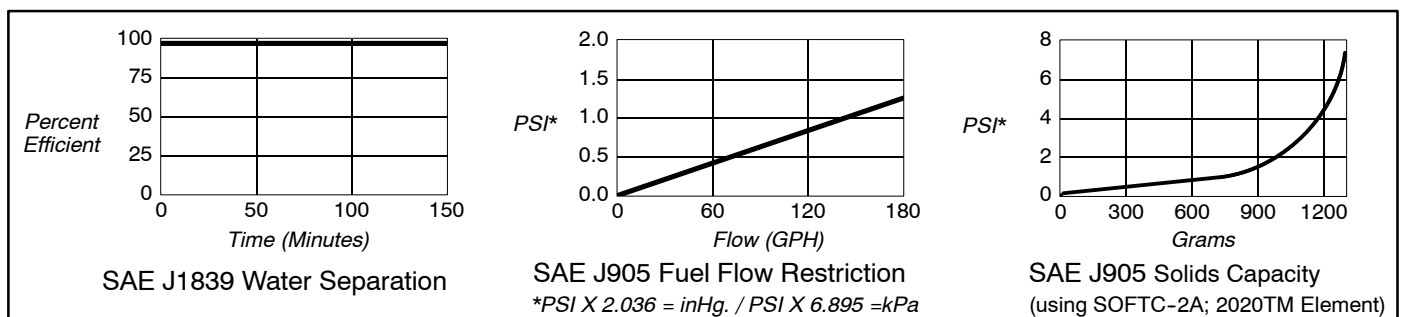

Racor Products

Section 4 Interceptor Products

- Interceptor Filter Products
- OEM Replacement Filters
- Fuel Dispensing Filters And Heads
- Alpha-numerical Parts List



Help & General
Information

Navistar 6.9l Replacement Fuel Filters

The Interceptor Direct Replacement Fuel Filter for the Navistar 6.9L diesel engine upgrades the standard fuel filter to a spin-on fuel filter and water separator with a metal bowl. At filter change time, only the spin-on can is replaced: the bowl spins off and is reusable. Interceptor Filter Products meet OEM specifications.

Part Number	Description	Qty./ Case
IN BF811	Replaces standard fuel filter on 6.9L diesel in Ford E & F Series vehicles	12
IN F811	Replacement Fuel Filter for above.	12
IN RK30785	Water Sensor Kit for IN BF811 applications. Replaces the OEM water sensor.	1

Navistar 6.9l Complete Replacement Assemblies

The Interceptor 6.9L Diesel Replacement Kits for Ford E & F Series vehicles are designed to upgrade the fuel filter system quickly and easily. The kit includes a fuel filter/water separator with an in-filter fuel heater and a water sensor probe that fits existing circuitry. A more reliable, higher quality, exact fit replacement is guaranteed!

Part Number	Description	Qty./ Case
IN RK30787	Navistar 6.9L Replacement Kit for Ford F Series trucks (uses IN F829B filter).	1
IN RK30801	Navistar 6.9L Replacement Kit for Ford E Series vans (uses IN F829B filter).	1
IN RK20567	Replacement Metal Bowl Kit for IN F811, IN F829B, IN F830 and IN F831	1
IN RK21057	Replacement Clear Bowl Kit for IN F811, IN F829B, IN F830 and IN F831	1

Replacement Filters For OEM Applications

Interceptor Filter Products offers patented replacement filter elements for specific OEM applications and engines.

Part Number	Description	Qty./ Case
IN F829B	Navistar 7.3L diesel in Ford E & F Series vehicles, 2 micron.	12
IN F830	Navistar 7.3L medium-duty trucks and buses, 40 micron.	12
IN F831	Navistar 6400 Series fuel heater/filter/water separators, 40 micron.	6
IN F4595	Navistar T444E (7.3L) Powerstroke (model years 1994 to 1999)	12
IN F4596	Navistar T444E (7.3L) Powerstroke (model year 1999 to current)	12
IN F4597	Ford 550 and 650 with Cat engines and cold weather element	12
IN F264	Bosch, Iveco, Deutz, MAN & Volvo fuel filter replacement (center thread: 16M).	12
IN F19528	Dodge trucks with Cummins engine, replacement element (model yrs. 1998 & 1999)	12
IN F296	CAV: Replaces CAV7111/296.	24
IN F796	CAV: Replaces CAV7111/796.	24
IN F3368	Ford 6.6L/7.8L engines, 1991 - 1992.	12
IN FR26P	Ford 6.6L/7.8L engines, 1985 - 1990.	12
IN F18786	Replaces Stanadyne Fuel Filter No.18667 (square, box-type)	12
IN F19797	Replaces Stanadyne Fuel/Water Separator No.19856 (square, box-type)	12
IN F52525	Replaces Webb #52525 / DDC Applications	12

Replacement Filters for Dahl

Part Number	Model / Micron	Qty./	Part Number	Model / Micron	Qty./
IN 101-2	100, 2 micron	18	IN 201-10	200, 10 micron	18
IN 101-10	100, 10 micron	18	IN 201-30	200, 30 micron	18
IN 101-30	100, 30 micron	18	IN 301-10	300, 10 micron	18
IN 201-2	200, 2 micron	18	IN 301-30	300, 30 micron	18

Fuel Dispensing Filters And Filter Heads

Interceptor fuel dispensing filters start protecting engines at the source, removing virtually 100% of contaminants from diesel or gasoline, including water, dirt, dust, rust and biological microorganisms. By trapping this contamination, precision fuel system components are protected from abrasion and wear. These units are essential for stationary pumps, overhead tanks, marinas and mobile service vehicles.

Interceptor fuel dispensing filters offer protection down to 10 microns. Flow rates range from 15 to 100 GPM. Filter servicing is clean and easy with just a spin.

Interceptor filters feature a super-absorbant, chemically-treated media with two unique features:

1. The filter media absorbs 25 times its weight in water and locks it in. It is an effective barrier against free and emulsified water.
2. As the media swells with water removed from the fuel, it gradually reduces the flow rate, signaling the need to replace the filter. The absence of a bypass valve insures that fuel system will be completely protected.

Interceptor filters are engineered and manufactured under the most up-to-date quality control processes to meet or exceed original equipment specifications.

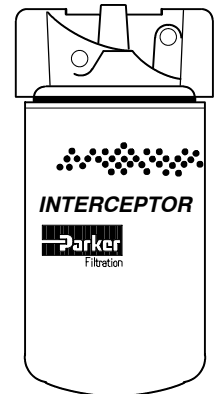

Water Absorbing Filters

Maximum operating pressure: 100 PSI / 689.6 kPa

¹IN FDC filters have a cellulose media and do NOT absorb water. ²Filters with the 'A' media hold more dirt and water than standard water absorbing media. More frequent element changes may be necessary.

Part Number	Micron Rating	Center Thread	Filter Diameter	Filter Length	Media Area (Sq in. /Sq cm)	Solids Capacity (g)	Water Capacity (ml)	Typical Beta Rating (uM)	Case Qty.
IN FDC3510G ¹	10	1 1/2"-16	3.75 in.	5.0 in.	480 / 3096	9.04	N/A	10/18	12
IN FDC3530G ¹	30	1 1/2"-16	3.75 in.	5.0 in.	480 / 3096	9.04	N/A	10/18	12
IN FDW3510	10	1"-12	3.75 in.	5.0 in.	190 / 1226	13.68	247	10/18	12
IN FDW3510A ²	10	1"-12	3.75 in.	5.0 in.	335 / 2161	13.68	175	10/18	12
IN FDW3525	25	1"-12	3.75 in.	5.0 in.	190 / 1226	15.58	247	14/23	12
IN FDW3810A ²	10	1"-12	3.75 in.	5.0 in.	608 / 3923	39.48	315	10/18	12
IN FDW3825	25	1"-12	3.75 in.	8.0 in.	350 / 2258	28.71	455	14/23	12
IN FDW3830	30	1"-12	3.75 in.	8.0 in.	350 / 2258	28.71	455	14/23	12
IN FDW51125	25	1 1/2"-16	5.0 in.	11.0 in.	689 / 4444	56.50	896	14/23	6

Filter Heads

Maximum operating pressure: 100 PSI / 689.6 kPa

¹ Head/element seal available: IN GCSG100, packaged 5/kit. ² Dual filter unit. Order two filters when using this model.

Part Number	Center Thread	Port Sizes	Fuel Flow Rate (GPM)	Filter Application	Bypass Setting	Restriction Gauge	Gauge Port	Case Qty.
IN HH07500	1"-12	3/4" NPT	15	FDW3525/FDW3825	No Bypass	Optional	1/8" NPT	1
IN FDH12500 ¹	1 1/2"-16	1 1/4" NPT	50	FDW51125	No Bypass	Optional	1/8" NPT	1
IN FDH125DD ^{1,2}	1 1/2"-16	1 1/2" NPT	100	FDW51125 (2)	No Bypass	Optional	1/8" NPT	1

CAV Filter Adapter Kit

Filter Adapter Kit IN CAV turns old C.A.V. Filter Head, cannister and glass bowl units into a spin-on filter. Fits Ford, Perkins, Massey Ferguson, Saab, Volvo-Penta and more! This kit allows the use of Interceptor Spin-On Filters that feature the patented see-thru, spin-on contaminant collection bowl: IN B32008 or IN B32016. For engines up to 70 HP.

C.A.V. Filter Head

IN CAV Adapter

Interceptor IN B32008 or IN B32016 Filter Assembly

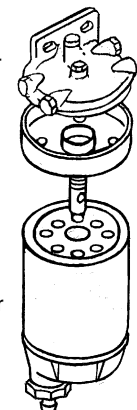

Part Number	Description	Applications	Qty./Case
IN CAV	Adapter Kit	Ford, Perkins, Massey, Saab, Volvo-Penta, Ford Lehman	1

Interceptor Filter Products

Alpha-numerical Parts List

Part No. Description

IN AF2030	Air Filter
IN AU10050	Filter Element / Finite
IN AU15060	Finite Au15-060X4
IN AU25235	Finite Element
IN BF811	IHC/Navistar 6.9L (w/ bowl)
IN BF829	IHC/Navistar 7.3L (w/ bowl)
IN CAV	CAV Adapter Kit
IN CF601030	3 mic. Dbl Length Liquid Bag
IN FC60039	40 SA Element Filter Cart
IN FC60040	03C Element Filter Cart
IN FC60041	10C Element Filter Cart
IN FC60042	20C Element Filter Cart
IN FC60043	03B Element Filter Cart
IN FC60044	10B Element Filter Cart
IN FC60045	40W Element Filter Cart
IN FC60046	74W Element Filter Cart
IN FC60047	Buna Hose Assy. Filter Cart
IN FC60048	Motor, 3/4 HP, Filter Cart
IN FC60049	Motor, 1/2 HP, Filter Cart
IN FC60050	Pump, 10 GPM, 5 GPM Filter Cart
IN FC60051	Cord, Reel Assy. Filter Cart
IN FC60052	4 Band Indicator, Filter Cart
IN FC60053	Magnet, Inlet Assy. Filter Cart
IN FC60065	Water Removing Element, Filter Cart
IN FC60097	N72350 Buna-N O-ring
IN FDH125DD	Head, Fuel Dispenser, Dual 125DD
IN FDH12500	Head, Fuel Dispenser, No By-pass
IN FDH200DD	Head, Fuel Dispenser, Dual 2" NPT
IN FDWEHS10	Fuel Dispensing, 10 mic, H ₂ O removing
IN FDWEHS30	Fuel Dispensing, 30 mic, H ₂ O removing
IN FDW3525	Fuel Dispenser. Filter/Water Removing.
IN FDW3805	Fuel Dispenser. Filter/Water Removing.
IN FDW3825	Fuel Filter, Dispenser, Screened
IN FDW3830	Fuel Filter, Dispenser, Screened
IN FDW51125	Fuel Filter, Dispenser, Screened
IN FFH10197	Finn Filter
IN FF60155	Filter Assembly
IN FF60156	Replacement Element
IN FF60157	Finn Element
IN FF60158	Finn Element
IN FF60159	Finn Element
IN FF60160	Finn Element
IN FF60161	Funnel
IN FF60163	Finn Element

Part No. Description

IN FR26P	Fuel Filter/Water Sep., Ford 6.6/7.8L
IN FWS3201	Fuel Filter/Water Sep.
IN FWS3206	IN B32006 w/ Head and Bracket
IN FWS3211	IN B32011 w/ Head and Bracket
IN FWS3222	Bracket, Head & Element, 90 GPM
IN F18786	Stanadyne Fuel Filter, Square Box
IN F19528	Cummins Replacement Element
IN F19797	Stanadyne Fuel/Water Sep., Sq Box
IN F264	Filter, Bosch, Iveco, Deutz, Mann, Volvo
IN F296	Filter, CAV 7111 / 296
IN F3368	Fuel Filter/Water Sep., Ford 6.6/7.8L
IN F4595	Navistar 7.3L Replacement Element
IN F4596	Navistar 7.3L Replacement Element
IN F4597	550 and 650 Cat. Engine Element
IN F796	Filter, CAV 711 / 796
IN F811	IHC/Navistar 6.9L (no bowl)
IN F829B	IHC/Navistar 7.3L (short)
IN F830	IHC/Navistar 7.3L (long)
IN F831	IHC/Navistar 6400 Series
IN GCSG100	Gasket 5 Pack, Buna-N, Hyd 90D
IN G60000	LTS Wire Element, 74
IN G60001	LTS Wire Element, 25
IN G60002	LTS Wire Element, 40
IN G60003	LTS Brass Fitting
IN G60004	LTS Inlet Hose
IN G60005	LTS Outlet Hose
IN G60006	LTS Element, 10C
IN G60007	LTS Element, 10B
IN G60008	LTS Microglass Element, 03B
IN G60009	LTS Element, WR
IN G60010	LTS Element, 20C
IN G60011	LTS Roll Pin, 1/8" x 5/8" IN G60012
IN G60012	LTS Roll Pin, 1/8" x 3/4"
IN G60013	LTS Gerotor Set
IN G60014	LTS End Cap
IN G60015	LTS Shadow Plate
IN G60016	LTS Outlet Plate
IN G60017	LTS Gerotor Ring
IN G60018	LTS Polypak Seal
IN G60019	LTS Viton Hose Gasket
IN G60020	LTS Wand Crevice Assy.
IN G60021	LTS Wand Adapter
IN G60022	LTS 5" Filter Extension Tube
IN G60023	LTS Quick Disconnect

Interceptor Filter Products

Alpha-numerical Parts List

Part No. Description

IN G60024	LTS Housing O-ring
IN G60025	LTS Gerotor O-ring
IN G60026	LTS Cap O-ring
IN G60027	Double Length Element, 40W
IN G60028	Double Length Element, 40SA
IN G60029	Double Length Element, 25W
IN G60030	Double Length Element, 20C
IN G60031	Double Length Element, 10B
IN G60033	Double Length Element, 03B
IN G60034	Double Length Element, 03C
IN G60035	Motor, 115 VAC
IN G60036	Inlet Screen
IN G60125	Guardian Brush Kit
IN G60126	Guardian Brush Cap
IN G60170	O'ring, Viton
IN HA495	WIR 34310 HGST E116LS
IN HC3510	Spin-on Element, 3" X 5", 10 mic.
IN HC3525	Spin-on Element, 3" X 5", 25 mic.
IN HC51110	Spin-on Element, 5" X 11", 10 mic.
IN HC51125	Spin-on Element, 5" X 11", 25 mic.
IN HC5710	Spin-on Element, 5" X 7", 10 mic.
IN HC5725	Spin-on Element, 5" X 7", 25 mic.
IN HF60054	Element, 9600 UP/UN4H
IN HF60055	Element, 9600 UP/UNBH
IN HF60056	Element, 9600 UP/UN13H
IN HF60057	Element, 9600 UP/UN16H
IN HF60058	Element, 9600 UP/UN132
IN HF60059	Element, 9600 US/UT4H
IN HF60060	Element, 9600 US/UT8H
IN HF60061	Element, 9600 US/UT13H
IN HF60062	Element, 9600 US/UT16H
IN HF60063	Element, 9650 US/UN8H
IN HF60064	Element, 9601 FUP8H
IN HF60066	Element, 8300 UP/UN8H
IN HF60067	Element, 8300 US/UT 39H
IN HF60068	Element, 9021 FUT8Z
IN HF60069	Element, 9021 FUT4Z
IN HF60070	Element, 9400 DPDN13H
IN HF60071	Element, 9400 DPDN20H
IN HF60072	Element, 8800 FDN16H
IN HF60073	Element, 8800 FDT16H
IN HF60074	DDA X-Mission 23040988
IN HF60098	Dbl Length Element, Schroeder KK3
IN HF60099	Dbl Length Element, Schroeder KKS7

Part No. Description

IN HF60100	Dbl Length Element, Schroeder KKS3
IN HF60101	Dbl Length Element, Schroeder KK10
IN HF60102	Pall, 9600, FWT4H
IN HF60103	High Collapse, Schroeder KSX3
IN HF60104	High Collapse, Schroeder KSX7
IN HF60105	Dbl High, Schroeder KKSX7
IN HF60106	Dbl High, Schroeder KKSX3
IN HF60116	Element, 10C, Euro 34P
IN HF60128	Hydraulic Element, 9650, Single
IN HF60129	Hydraulic Element, 20C-15P
IN HF60131	Hydraulic Element, 03BX
IN HF60132	Hydraulic Element
IN HF60133	Head, 15P Housing
IN HF60135	Dbl Length Element, 10B
IN HF60136	Element, 10C, Single
IN HF60137	Element, 10B, w/ Viton Gasket
IN HF60138	Element, 10C
IN HF60141	Double Length Element, 10C
IN HF60142	Element, 10C, 31P
IN HF60143	Double Element, 10C
IN HF60144	Element, 25W, 61P
IN HF60148	Element, 25 Micron
IN HF60150	Hydraulic Element, 5Q
IN HF60151	Element, 25W, 907232
IN HF60152	Element, 10C
IN HF60153	Hydraulic Element
IN HF60154	Hydraulic Element
IN HF60162	Filter Housing w/ Bowl
IN HF60164	Element, 10B
IN HF60165	Element, 10B
IN HF60166	Element, 02HC
IN HF60167	Element, 10B
IN HF60168	Element, 03C
IN HF60169	Restriction Indicator
IN HF60171	Element, 10C
IN HF60174	Gasket for IN HF60080
IN HF60175	Bowl O'ring for IN HF60080
IN HF60176	Hydraulic Element
IN HF60177	Hydraulic Element, 2 Micron
IN HF60179	Element, 03C
IN HG15LF	Gauge, Liquid Filled 1.5" D. Dial
IN HH07500	Head, Fuel Dspnsg, 3/4"NPT, 1"-12UNF
IN HH07503	Head, Hydraulic ,3/4"NPT, 1"-12UNF
IN HH07515	Head, Hydraulic ,3/4"NPT, 1"-12UNF

Interceptor Filter Products

Alpha-numerical Parts List

Part No. Description

IN HH07515MP	Head, Multi-port, 3/4"NPT, 1"-12UNF
IN HH07525	Head, Hyd., 3/4"NPT, 25 PSI By-pass
IN HH07525MP	Head, Multi-port, 3/4"NPT, 1"-12UNF
IN HH12515L	Head, 1 1/4"NPT, 1 1/2"-16UN/L
IN HH12515MP	Head, Multi-port, 1 1/4"NPT, 1 1/2"-16UN
IN HH12515R	Head, 1 1/4"NPT, 1 1/2"-16UN-R
IN HH12525L	Head, 1 1/4"LEFT, 25 PSI
IN HH12525MP	Head, Multi-port, 1 1/4"NPT, 1 1/2"-16UN
IN HH12525R	Head, 1 1/4"NPT, 1 1/2"-16UN/L
IN HMG3606	Microglass element, 3" x 6" x 1 1/2"-16
IN HM3504A	Hydraulic Spin-on, 3 x 5 x 1, 1/2"-16
IN HM5710	Hydraulic Element, 5 x 7, Micro Glass
IN HN4L10CN	Filter Assembly
IN HN92151	O'ring
IN HP60077	Filter, Hydraulic Pressure, 20GPM
IN HP60078	Element, 10C, 60077 Housing
IN HP60079	Element, 10B, 60077 Housing
IN HP60080	Filter, Hydraulic DBL, 20 GPM
IN HP60081	Element, 10C, 60080 Housing
IN HP60082	Double Element, 10B, 60080 Housing
IN HP60083	Filter, Hydraulic Pressure, 50GPM
IN HP60084	Element, 10C, 60083 Housing
IN HP60085	Element, 10B, 60083 Housing
IN HP60086	Filter, Hydraulic Pressure, DBL.50 GPM
IN HP60087	Element, DBL. 10C, 60086 Housing
IN HP60088	Double Element, 10B, 60086 Housing
IN HP60089	Rotary Indicator
IN HP60090	Element, DBL. 03C, 60080 Housing
IN HP60092	Element, 74W, S Series
IN HP60093	Element, 20C, 2"
IN HP60094	Element, 10Micron, K Series
IN HP60095	Element, SNGL.03C, 60077 Housing
IN HP60096	Element, 9600 FDT8H
IN HP60107	High Collapse Element, 10BX
IN HP60108	Element, 20C, 60083 Housing
IN HP60109	High Collapse, 10B, 60086 Housing
IN HP60115	Side Mount Rotary Dial
IN HP60119	High Collapse, 03B, 60083 Housing
IN HP60121	Element, 40CN-2, 10C Viton
IN HP60122	Element, 40CN-2, 10B Viton
IN HP60123	Element, 50S, 10C
IN HP60124	Element, 50P-1, 10B
IN HP60139	Double Element, 10B, 2"
IN HP60140	Buna Element, 10C

Part No. Description

IN HP60145	Element, 03B
IN HP60146	Filter Head
IN HP60147	Housing w/ High Collapse Element
IN HRBA11216	Breather Adapter, 1"-12, 1 1/2"-16
IN HRBA3416	Breather Adapter, 3/4"-16, 1"-12
IN HSSM511	Element, Stainless Steel Mesh, 5" x 11"
IN HSSM57	Element, Stainless Steel Mesh, 5" x 7"
IN HW33RB	Reservoir Breather, 3"x3", 10 micron, water absorbing.
IN HW35RB	Reservoir Breather, 3"x5", 10 micron, water absorbing.
IN HW3510	Spin-on Hydraulic element, 3" X 5", 10 micron, water absorbing, 1"-12 thread.
IN HW3510A	Same as above but w/ 1 1/8"-16 thrds.
IN HW3525	Spin-on Hydraulic element, 3" X 5", 25 micron, water absorbing.
IN HW3810	Spin-on Hydraulic element, 3" X 8", 10 micron, water absorbing.
IN HW3825	Spin-on Hydraulic element, 3" X 8", 25 micron, water absorbing.
IN HW51110	Spin-on Hydraulic element, 5" X 11", 10 micron, water absorbing.
IN HW51125	Spin-on Hydraulic element, 5" X 11", 25 micron, water absorbing.
IN HW57RB	Reservoir Breather, 5"x7", 10 micron, water absorbing.
IN HW5710	Spin-on Hydraulic element, 5" X 7", 10 micron, water absorbing.
IN HW5725	Spin-on Hydraulic element, 5" X 7", 25 micron, water absorbing.
IN KX1	Adapter, Hankison to Finite
IN KX22	Kit, Hankison to Finite
IN KX23	Kit, Hankison to Finite
IN KX24	Kit, Hankison to Finite
IN KY1	Adapter, Wilkerson
IN N72240	Bowl O'ring, 40CN Buna
IN PF60178	Filter Housing
IN RBA60075	Breather Adapter, Reservoir
IN RBA60076	Breather Adapter, Reservoir
IN RBTB050	Breather Adapter, 1/2" NPT, 5 x 7
IN RB926875B	Pipe Nipple, 125 11216 THDB
IN RB926876B	Pipe Nipple, 075 112THD
IN RK20567	Kit, Metal Bowl / Drain, BF811
IN RK21044	Kit, Deep Clear Bowl

Interceptor Filter Products

Alpha-numerical Parts List

Part No. Description

IN RK21057	Kit, Clear Bowl / Drain, BF811
IN RK30287	Head, 320, 1"-14 adapter
IN RK30475	Kit, 320 Bowl w/o Sensor Port
IN RK30480	Kit, 325 Bowl w/o Sensor Port
IN RK30785	Kit, Water Detector, 6.9L/BF811
IN RK30787	Kit, Retrofit, FF/WS & WIF, 6.9L
IN RK30801	Kit, Retrofit, FF/WS 'E', 6.9L
IN SK-12	Repair Kit, John Deere
IN SK-16	Repair Kit, John Deere
IN S3222	Element, Thermoking
IN TA2062	Filter, Allison Transmission, 6 micron
IN TA60075Q	Filter, Allison Transmission, 6 micron
IN TA60076Q	Filter, Allison Transmission, 6 micron
IN TA6898	Filter, Allison Transmission, 6 micron
IN TA6899	Filter, Allison Transmission, 6 micron
IN 10CM1002	Filter
IN 10CM10025	Filter, Air, 10CM10-025X8
IN 10CM15060	Filter, Air, 10CM15-060X4
IN 10CU25260	Filter, Air, 10CU25-260X1
IN 10C15060	Filter, Air, 10C15-060X4
IN 10DP19098	Filter, Air, 10DP19-098
IN 10DP30295	Filter, Air, 10DP30-295X1
IN 10DS25280	High Temp After Filter, Grade 10
IN 10DS85250	Filter, Air
IN 10H04013	Filter, Air, 10H04-03X10
IN 10H10025	Filter, Air, 10H10025X8
IN 10H10070	Filter, Air, 10H10-70X4
IN 10H15060	Filter, Air, 10H15-060X4
IN 10H20187	Filter, Air, 10H20-187X1
IN 10QU10025	H Housing, Replacement Element
IN 10QU51280	Element Assembly
IN 10QU85360	Element Assembly, 8.5 x 36, H Series
IN 10S04023	Element, Replacement, Balston
IN 101-10	Filter, Diesel, Dahl 101, 10 micron
IN 101-2	Filter, Diesel, Dahl 101, 2 micron
IN 101-30	Filter, Diesel, Dahl 101, 30 micron
IN 14JU10020	Filter, Air, 14JU10-020X10
IN 14JU15043	Filter, Air, 14JU15-043X10
IN 14JU26075	Filter, Wilk, FRP95273
IN 14JU26120	Filter, Air, 14JU26-120
IN 201-10	Filter, Diesel, Dahl 201, 10 micron
IN 201-2	Filter, Diesel, Dahl 201, 2 micron
IN 201-30	Filter, Diesel, Dahl 201, 30 micron
IN 3PP14051	Element Assembly, 3PP14-051

Part No. Description

IN 3PP15098	Element Assembly, 3PP15-098
IN 3PP15198	Element Assembly, 3PP15-198 (20")
IN 3PP19098	Element, Air, 3PP19-098
IN 3PP26132	Element Assembly, 3PP26-132x2
IN 3PP30143	Element Assembly, 3PP30-143x1
IN 3PP30295	Element Assembly, 3PP30-295x1
IN 3PU15060	Element Assembly, 3PU15-0600R
IN 3PU15095	Element, 1 1/2 x 9 1/2
IN 3PU20130	Element Assembly, 3PU20-130X2
IN 3PU20187	Element Assembly, 3PU20-187X1
IN 3PU25187	Element Assembly, 3PU25-187X1
IN 3PU35280	Element Assembly, 3PU35-280X1
IN 3PU51280	Element Assembly, 3PU51-280X1
IN 3PWC08033	Element, Assembly, J Series
IN 3PWC23130	Element, Assembly, J Series
IN 3P70250	Finite Air Filter
IN 30060	Spin-on Unit Service Guide
IN 301-10	Filter, Diesel, Dahl 301, 10 micron
IN 301-30	Filter, Diesel, Dahl 301, 30 micron
IN 3222	Spin-on Filter
IN 4C10050	Element, H Series, 4C10050X4
IN 4C15060	Element, H Series, 4C15060X4
IN 6CJ25240	Element Assembly, 6CJ25-240X1
IN 6CL25063	Element, 6CL25063X2
IN 6CM10050	Element, 6CM10-050X4
IN 6CM15095	Element, 6CM15-095X2
IN 6CU10021	Element, 6CU10-021X8
IN 6CU15060	Element, 6CU15-060X4
IN 6CU15095	Element, 6CU15-095OR
IN 6CU20130	Element, H Series, 2X13
IN 6CU20187	Element, 6CU20-187X1
IN 6CU25130	Element Assembly
IN 6CU25187	Element, Hankinson 0713-12
IN 6CU25260	Finite Filter
IN 6CU25280	Element Assembly
IN 6CU35280	Coalescing Element, 3 Micron
IN 6CZ20086	Coalescing Element, 3 Micron
IN 6C04023	Element Assembly
IN 6C10025	Element, PIN/Q
IN 6C10050	Element Assembly, 6C10-050X4
IN 6C15060	Element, H Series, 6C15-060x4
IN 6C15095	Element Assembly, 6C15095 x 2
IN 6C70250	Finite Air Filter
IN 6G10025	Particulate Element

Interceptor Filter Products

Alpha-numerical Parts List

Part No. Description

IN 6G20090 Element, Balston 20035-371H
IN 6H10050 Element Assembly, 6H10-050X4
IN 6H20187 Element, 6H20187
IN 6ICC25240 Element, 6ICC25-240X1
IN 6QP14051 Element Assembly, 6QP14-051X4
IN 6QP19098 Element, Air, 6QP19-098
IN 6QP30143 Element, Air Filter
IN 6QP30295 Element Air, 6QP30-295
IN 6QU10025 Element
IN 6QU13042 Element Assembly, 6QU13-042
IN 6QU51280 Element Assembly
IN 6QU85250 Element Assembly, 6QU85-250x1IN
IN 6QU85360 Element Assembly, 6QU-85-360X1
IN 66025K000 Accumulator

Part No. Description

IN 700530 Coalescing Element
IN 718-20 Element Assembly, 7 X 18, 20 mic.
IN 718-30 Element Assembly, 7 X 18, 30 mic.
IN 718-5 Element Assembly, 7 X 18, 5 mic.
IN 74P10021 Element Assembly
IN 7439 Interceptor Parts Book
IN 76114V Gasket
IN 76143 Gasket
IN 8DC25240 Element Assembly, 8DC25-240X1
IN 8DU78165 Element Assembly, 8DU78-165X1
IN 8G10025 Element, Grade 8, Particulate
IN 8H20187 Element, Air Filter
IN 8QU51280 Element, Air Filter

Racor Products

Section 5 Lubrication Filtration Systems

- Selection
- Full-Flow Cleanable
- LFS 35
- LFS 62/64
- LFS 92
- By-Pass Models
- Spin-on Series
- By-Pass Series
- Accessories
- Fittings
- Troubleshooting



Help & General
Information

Selection Information

General

Racor Lubrication Filtration Systems are permanent, full flow units which contain a reusable, stainless steel wire cloth filter which is designed to effectively trap damaging solids.

An added value of the wire cloth filter is its effectiveness as a visual diagnostic tool to monitor potential engine wear. Cleanup of the wire cloth filter is easy. The filter can be soft brushed in solvent or cleaned in a parts washer, then re-inserted between the permanent housings. Racor Lubrication Filtration Systems (LFS) are available in two unique design configurations: A conventional 'sandwich' type and the new 'spin-on' type.

The standard LFS 'sandwich' type units utilize a flat disc shaped wire cloth filter that fits between die-cast aluminum housings. This cleanable filter design is available in a choice of micron ratings. The standard oil filter is replaced by an adapter which spins onto the filter header. Adapters are available to fit virtually any engine.

The new Spin-on 700 Series feature a cylindrical shaped wire cloth filter that fits inside an aluminum housing. This model directly replaces the standard oil filter right on the engine or may also be located in a convenient remote location.

Most Racor LFS systems come standard with a warning light feature. When the wire cloth filter reaches its restriction capacity, the system goes into a by-pass mode and the light signals the operator there is a need for service. Frequency of filter cleansing is determined by the contamination levels present in the fluid. The cleaning interval may be more frequent when first installed. The units are rated by the flow rate of the fluid.

The draining, crushing, accounting and related liabilities associated with used spin-on type filter disposal are eliminated with these permanent filter designs.

1. DETERMINE THE TYPE OF LFS UNIT FOR YOUR APPLICATION:

- A. REMOTE MOUNT LFS
- B. SPIN-ON 700 SERIES, ENGINE MOUNT
- C. BY-PASS FILTRATION, REMOTE MOUNT

2. DETERMINE THE FLOW RATE OF THE FLUID TO BE FILTERED.

You may also match a unit by the engine size as follows:

LFS35: 6 GPM. Automatic transmissions, small engines, small motorcycles and AC power generators.

LFS62 or 64: 20 GPM. Medium / heavy-duty applications, on and off-road and marine equipment.

LFS92: 45 GPM. Large diesel engine oil, transmission and low pressure hydraulic return lines.

LFS 700 Series. Large diesel engine oil: Caterpillar, Cummins, Detroit Diesel, Mack and Navistar.

62 or 64BP: By-pass filtration, up to 20 GPM and 92BP: By-pass filtration up to 45 GPM.

LFS 800 Series: By-pass filtration recommended for use with the LFS 700 Series filters.

3. DETERMINE THE DESIRED CLEANLINESS FOR THE SYSTEM:

5 Micron: (.0002") and

10 Micron: (.0004") are Recommended for by-pass oil filtration and hydraulic fluid.

Above filters not for use with full flow lubrication oil supply.

28 Micron: (.0011") Fine filtration recommended for engine oil and transmission filtration.

40 Micron: (.0016") Recommended for primary engine oil and transmission filtration.

60 Micron: (.0024") Recommended for coolant systems and hydraulic return lines.

115 Micron: (.0045") Porous filter, recommended for coolant systems.

Using this information, select a unit from the following page index. Also, refer to the specific liquid filtration unit information pages which follow.

Model Illustrations

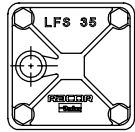

LFS 35

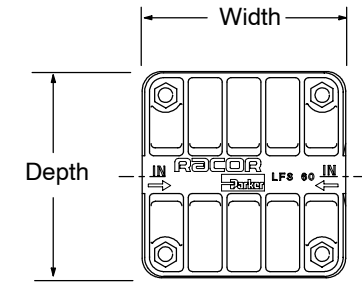

LFS 62 / 64
and 62/64BP

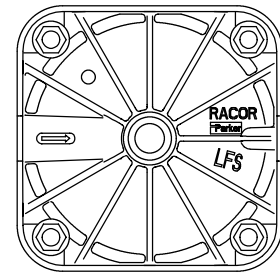

LFS 92 and 92BP

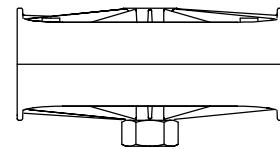
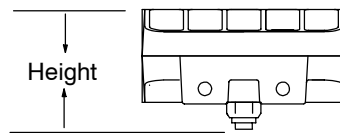
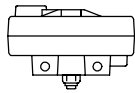

Special Notes

1. For additional information and availability, contact customer service at: (800) 344-3286, 6 AM to 5 PM, Pacific Time.

Specifications

BASIC MODELS		LFS 35	LFS 62 / 64 62 / 64BP	LFS 92 92BP
Fluid Flow Rate (Maximum)	GPM	6	20	45
	LPM	22.7	75.7	170.3
Hose Size (min).	I.D.	3/8" (#6)	5/8" (#10)	1" (#16)
PSI, Maximum	PSI	150	150	150
	kPa	1034	1034	1034
Screen Size	Micron	28, 40	5, 10, 28, 40, 60, 115	5, 10, 28, 40, 60, 115
Port Size		3/8" NPT	1 1/16"-12 SAE	1 5/16"-12 SAE
Height	in.	2.45	3.50	4.75
	mm	62.3	83.9	120.7
Width	in.	3.63	6.00	9.62
	mm	92.1	152.0	244.4
Depth	in.	3.63	6.00	9.50
	mm	92.1	152.0	241.3
Weight (dry)	Lbs.	1.21	4.3	10.6
	kgs.	.55	1.95	4.81

- Notes: 1. For accurate engine flow rates, consult your engine or equipment manual, manufacturer's agent or a Racor distributor.
 2. Oil change frequencies are not affected and should be performed according to the manufacturer's recommendations.
 3. The only accredited way to extend your oil change interval is through a formal lube analysis program.

SPECIFICATIONS are found on the Lubrication Filtration Systems introduction page.

How to Order - The example below illustrates how the part numbers are constructed.

LFS 35	28	TT
<u>Basic Unit</u> 6 GPM Lubrication Filtration System with 3.5" diameter filter.	<u>Filter Micron Rating.</u> Specify: '28' for 28 micron or '40' for 40 micron	<u>Light Switch</u> Note: Do not use with gasoline or other volatile fluids. (Omit if not desired).

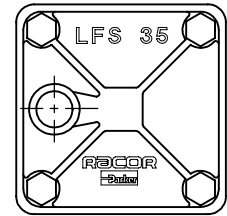

LFS 35

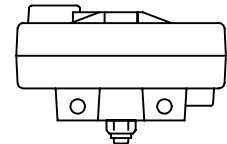

Illustrated Parts List

Item	Part No.	Description	Qty.
1	46003	Gasket, Plug/Switch	1
2	46005	Spring, 6" series	1
3	LFS RK35BB	Check Ball, 1/2" diameter	1
4	46004	Plug, 6" series	1
5	LFS RK356LS ¹	By-pass Sensor	1
6	46037	Housing, Outlet	1
7	LFS 3528WCF	28 Micron Stainless Steel Filter	1
	LFS 3540WCF	40 Micron Stainless Steel Filter	1
8	46036	Housing, Inlet	1
9	46039	Washer	4
10	46147	Universal Stud, 5/16" x 1 1/2"	4
	12048	Hex Nut	4
	46079	Installation Instructions	
	46090	Instruction Addendum	

¹ Do not use sensor when filtering gasoline/volatile fluids.
For visual indicator kits, fittings, hose information and adapters, see the Accessories Section.

Mounting Hole Pattern / Performance Graph

(Not to scale)

Inlet
-Outlet is on bottom half.
Port sizes are:
3/8" NPT

1.50" (38 mm)
1.75" (44 mm)

Clearance for 1/4" (6.35 mm) fasteners.

-Refer to Lubrication Filtration Systems introduction page for more information.

These results are from controlled laboratory tests using MIL-H-5606 hydraulic fluid & 28 micron filter. Field results may vary by application.

Differential Pressure, PSI*

Flow Rate (GPM)

Flow Rate vs Restriction

*PSI X 2.036 = inHg. / PSI X 6.895 = kPa

Flow Rate (GPM)	Differential Pressure (PSI*)
0	0
1	1.0
2	2.0
3	3.0
4	4.0
5	5.0
6	6.0

SPECIFICATIONS are found on the Lubrication Filtration Systems introduction page.

How to Order -The example below illustrates how the part numbers are constructed.

LFS 62	28	TT
<u>Standard Unit</u> 20 GPM, Six inch (6") diameter filter. Features one inlet and outlet port. Specify the LFS 64 for two inlet/outlet ports.	<u>Filter Micron Rating.</u> Specify the micron rating by number: 28, 40, 60 or 115	<u>Light Switch</u> Note: Do not use with gasoline or other volatile fluids. (Omit if not desired).

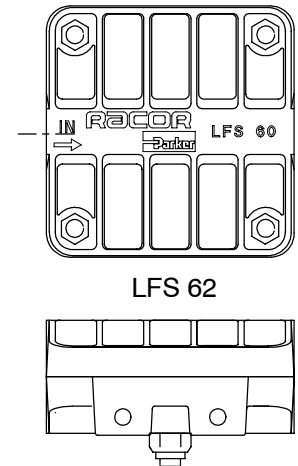

Illustrated Parts List

Item	Part No.	Description	Qty.
1	46003	Gasket, Plug/Switch	1
2	46005	Spring, 6" series	1
3	LFS RK60BB	Check Ball, 5/8" diameter	1
4	46004	Plug, 6" series	1
5	LFS RK356LS ¹	By-pass Sensor	1
6	46010	Housing, Outlet, LFS 62	1
	46131	Housing, Outlet, LFS 64	1
7	46181	Port Plug, #12	2
8	LFS 6028WCF	28 Micron Stainless Steel Filter	1
	LFS 6040WCF	40 Micron Stainless Steel Filter	1
	LFS 6060WCF	60 Micron Stainless Steel Filter	1
	LFS 60115WCF	115 Micron Stainless Steel Filter	1
9	LFS RK60SK	Stud, 3/8" X 1 1/2"	4
10	46009	Housing, Inlet, LFS 62	1
	46132	Housing, Inlet, LFS 64	1
11	46002	Washer	4
12	46001	Nut, 3/8"-16 X 9/16"	4
13	LFS RK60MFK	6"Optional Multi-filter Kit	1
	46182	Installation Instructions	
	46090	Instruction Addendum	

¹ Do not use sensor when filtering gasoline or volatile fluids. For visual indicator kits, fittings, hose information and adapters, see the Accessories Section.

5

Mounting Hole Pattern / Performance Graph

-Refer to Lubrication Filtration Systems introduction page for more information.

(Not to scale)

Inlet
-Outlet is on bottom half.
Port sizes are: 1 1/16"-12 (SAEJ1926)

Clearance for 1/4" (6.35 mm) fasteners.

2.30" (58 mm)

2.32" (59 mm)

These results are from controlled laboratory tests using MIL-H-5606 hydraulic fluid & 40 micron filter. Field results may vary by application.

Differential Pressure, PSI*

Flow Rate (GPM)

Flow Rate vs Restriction

*PSI X 2.036 = inHg. / PSI X 6.895 = kPa

SPECIFICATIONS are found on the Lubrication Filtration Systems introduction page.

How to Order -The example below illustrates how the part numbers are constructed.

LFS 92	28	TT
Standard Unit 45 GPM, Nine inch (9") diameter filter. Features one inlet and outlet port and two 1/4"NPT service ports.	Filter Micron Rating. Specify the micron rating by number: 28, 40, 60 or 115	By-pass Sensor Switch Visual indicator not included. See Accessories. Note: Not for use with gasoline/ volatile fluids. (Omit if not desired).

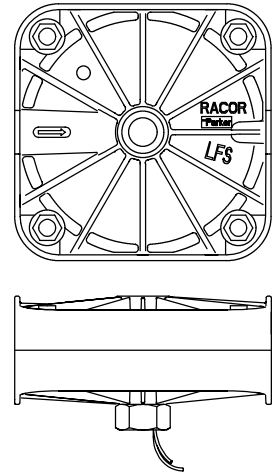

Illustrated Parts List -Refer to the Accessories Section for items not listed.

Item	Part No.	Description	Qty.
1	46029	Nut, 5/8"-18	4
	46028	Washer	4
2	46202	Housing, Inlet	1
3	LFS9028WCF	28 Micron Stainless Steel Filter	1
	LFS9040WCF	40 Micron Stainless Steel Filter	1
	LFS9060WCF	60 Micron Stainless Steel Filter	1
	LFS90115WCF	115 Micron Stainless Steel Filter	1
4	LFS RK90SK	Stud, 5/8"-18 X 2 1/8"	4
5	46203	Housing, Outlet	1
6	46204	Mounting Bracket	1
7	LFS RK46138 ¹	By-pass Sensor Switch,	
8	46165	By-pass Plug	1
9	46138	By-pass Relief Valve	1
10	46139	Spring, LFS90	1
11	46152	O-ring, Size #920	1
	46180	Installation Instructions	
	46090	Instruction Addendum	

¹ Do not use sensor when filtering gasoline or volatile fluids. For visual indicator kits, fittings, hose information and adapters, see the Accessories Section.

Mounting Hole Pattern / Performance Graph

Refer to Lubrication Filtration Systems introduction page for more information.

1/4"NPT Service ports are on each Housing, opposite the inlet or outlet ports.

Inlet is on top half, Outlet is on bottom half. Port sizes are 1 5/16"-12 (SAEJ1926)

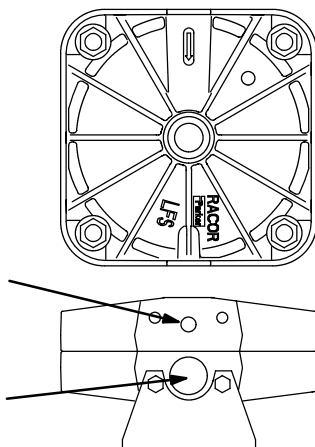

These results are from controlled laboratory tests using MIL-H-5606 hydraulic fluid & 40 micron filter. Field results may vary by application.

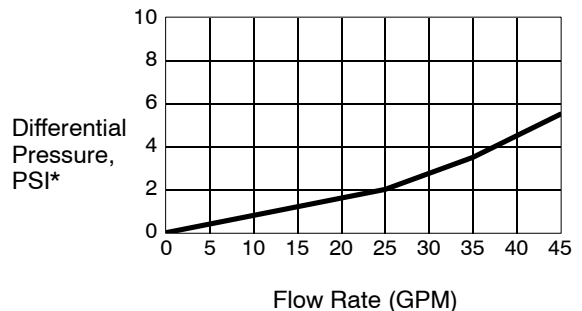

Flow Rate vs Restriction

*PSI X 2.036 = inHg. / PSI X 6.895 = kPa

Lubrication Filtration Systems

By-Pass Models

SPECIFICATIONS -See introduction page.

How to Order -See example below.

LFS 62	05BP
Specify: 62 or 64 for 20 GPM, 6" diameter filter, or 92 for 45 GPM, 9" diameter filter. One inlet and one outlet, standard on either size.	By-pass filtration. Specify: 05BP for 5 micron filter or 10BP for 10 micron filter.

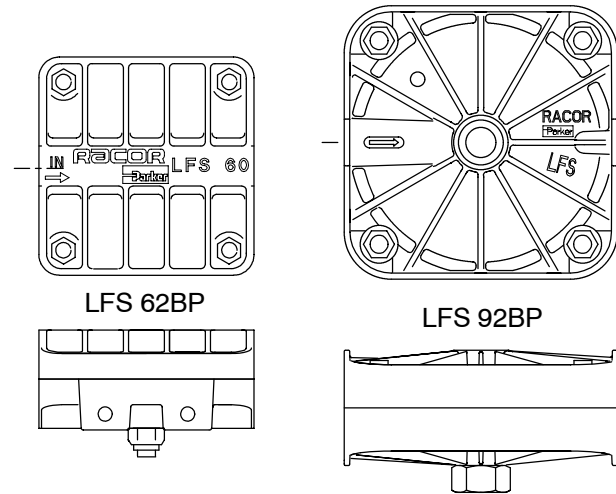

Illustrated Parts List

LFS 64BP shown

Item	Part No.	Description	Qty.
1	46004	Plug, 62 / 64	1
2	46003	Gasket, Plug 62 / 64	1
3	46005	Spring, 62 / 64	1
4	46006	By-pass ball, 5/8" dia.	1
5	46156	Housing, Outlet, 62	1
	46010	Housing, Outlet, 64	1
	46154	Housing, Outlet, 92	1
6	LFS6005WCF	LFS62: 5 Micron Stainless Steel Filter	1
	LFS6010WCF	LFS62: 10 Micron Stainless Steel Filter	1
	LFS9005WCF	LFS92: 5 Micron Stainless Steel Filter	1
	LFS9010WCF	LFS92: 10 Micron Stainless Steel Filter	1
7	46157	Housing, Inlet, 62	1
	46009	Housing, Inlet, 64	1
	46155	Housing, Inlet, 92	1
8	46165	By-pass Plug, 92	1
9	46152	O-ring, Size #920	1
10	46139	Spring, 92	1
11	46166	By-pass relief valve	1
12	LFS RK60SK	Stud, 3/8"-24 X 2"	4
	LFS RK90SK	Stud, 5/8"-18 X 2 1/8"	4
13	46002	Washer, 3/8"	4
	46028	Washer	4
14	46001	Nut, 3/8"-24	4
	46029	Nut, 5/8"-18	4
15	46204	Mounting Bracket 92 (not shown)	1
	46168	Installation Instructions	

5

Mounting Hole Pattern - Not to Scale

LFS 62 / 64BP

Inlet is on top half, Outlet is on bottom half.
Port sizes are: 1 1/16"-12 (SAEJ1926)

Clearance for 1/4" (6.35 mm) fasteners.

LFS 92BP

1/4"NPT Service ports are on each Housing, opposite the inlet or outlet ports.

Inlet is on top half, Outlet is on bottom half. Port sizes are 1 5/16"-12 (SAEJ1926)

Model Illustration

No Scale

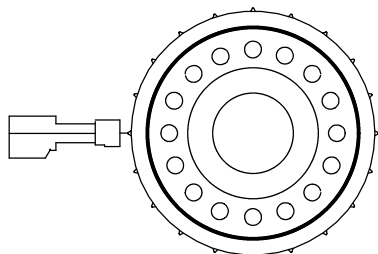

Engine Side (Seal Side) View

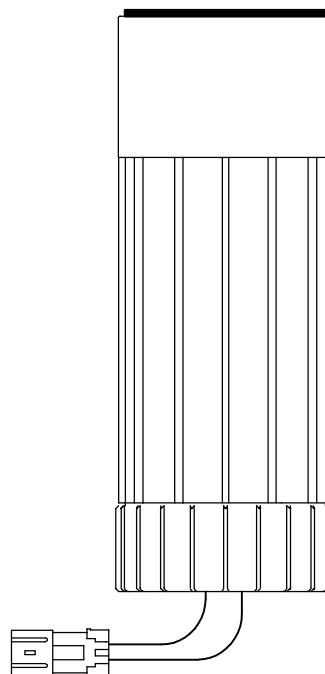

LFS 700LS Series

Special Notes

1. For additional information and availability, contact customer service at: (800) 344-3286, 6 AM to 5 PM, Pacific Time.

Specifications

BASIC MODELS		LFS 700LS	LFS 703LS	LFS 705LS	LFS 707LS	LFS 710LS	LFS 712LS	LFS 714LS	LFS 718LS
Flow Rate (Maximum)	GPM	45	45	45	45	45	45	45	
	LPM	170	170	170	170	170	170	170	
PSI, (max.)	PSI	150	150	150	150	150	150	150	150
	kPa	1034	1034	1034	1034	1034	1034	1034	1034
Diff. Pressure	PSI	7.5	7.5	7.5	7.5	7.5	7.5	7.5	
	kg/cm ²	.52	.52	.52	.52	.52	.52	.52	
Outer Element	(mic)	25	25	25	25	25	25	25	25
Inner Element	(mic)	10	N/A	N/A	N/A	N/A	N/A	N/A	N/A
Clearance for element removal	in.	21	21	21	21	21	21	21	12
	cm	53.3	53.3	53.3	53.3	53.3	53.3	53.3	30.5
Height	in.	12.25	12.25	12.25	12.25	12.25	12.25	12.25	7.5
	cm	31	31	31	31	31	31	31	19.1
Diameter	in.	4.5	4.5	4.5	4.5	4.5	4.5	4.5	4.5
	cm	11.4	11.4	11.4	11.4	11.4	11.4	11.4	11.4
Weight (dry)	Lbs.	6.8	6.2	6.2	6.2	6.2	6.2	6.2	4.1
	kgs.	3.1	2.8	2.8	2.8	2.8	2.8	2.8	1.9

- Notes: 1. For accurate engine flow rates, consult your engine or equipment manual, manufacturer's agent or a Racor distributor.
 2. Oil change frequencies are not affected and should be performed according to manufacturer's recommendations.
 3. The only accredited way to extend your oil change interval is through a formal lube analysis program.

Lubrication Filtration Systems

LFS 700LS Series

SPECIFICATIONS are found on the Lubrication Filtration Systems introduction page.

How to Order -The example below illustrates how the part numbers are constructed.

LFS	700LS
Lubrication Filtration Systems. Spin-on oil filter with cleanable and reusable stainless steel cartridge for diesel engines. Includes internal by-pass (opens at 24 PSID) with differential pressure sensor switch and panel mount indicator.	Model: Center Mounting Thread. Specify one: 700LS: 2 1/4"-12 710LS: 1 3/8"-16 703LS: 1 1/2"-12 712LS: 1 1/2"-16 705LS: 1 5/8"-12 714LS: 36M X 1.5 707LS: 1 1/8"-16 718LS: 1 1/2"-16

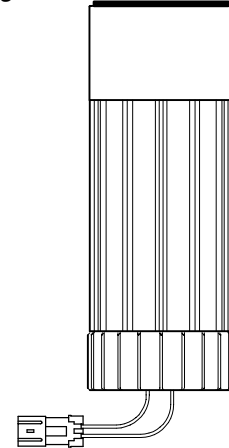

Illustrated Parts List -Refer to the Accessories Section for items not listed.

Item	Part No.	Description	Qty.
1	LFSRK755	Seal Kit (700-714LS)	1
	LFSRK758	Seal Kit (718LS)	1
2	46502-01	Housing, LFS 710LS	1
	46502-02	Housing, LFS 703LS	1
	46502-03	Housing, LFS 707LS	1
	46502-04	Housing, LFS 712LS	1
	46502-05	Housing, LFS 705LS	1
	46502-06	Housing, LFS 700LS	1
	46502-07	Housing, LFS 714LS	1
	46502-08	Housing, LFS 718LS	1
3	LFSRK750	Element, Outer (Dual element only)	1
4	LFSRK751	Element, Inner (Dual element only)	1
	LFSRK759	Element, (703-714LS Series)	1
	LFSRK757	Element, (718LS only)	1
5	46574	Element Retainer, Outer	1
6	46521	Spring, Main Compression	1
7	LFSRK753	End Cap, LFS 700LS Series	1
	46539	700 Series Installation Instructions	
8	46013	Light and Panel Kit, 12V	1
9	46065	Light Only	1

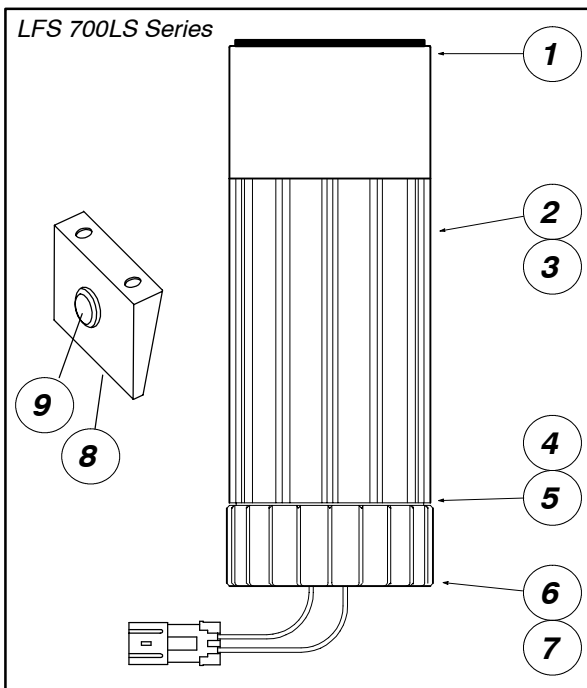

5

Applications List -Contact Racor Customer Service for applications not listed.

Engine Make	Engine Model	LFS Model
CATERPILLAR	3116, 3208T, 3304, 3306	LFS 707LS
	3176, 3406, 3408, 3412, C10, C12	LFS 712LS
CUMMINS	All engines using LF-3000 combination full flow by-pass filter	LFS 700LS
	C Series, L10, N-14, Big Cam IV	
	230, 240, NTC-250, 290, 300	
	350, 355, 370, 400, All KT	LFS 703LS
DETROIT	*Series 50 & 60, 1993 MY and on	LFS 705LSK
	All 53, 71, 92, 149 Series & Pre '93 Series 60	LFS 703LS
MACK TRUCK	EM-6, EN, ENDT,*EM-7	LFS707LSK
NAVISTAR	6.9, 7.3, 7.3 Power Stroke	LFS 718LS
	DT-466, 1994 and on	LFS 714LS

*Some engines use 2 filters. The KT kit provides 2 filter Assemblies.

These results are from controlled laboratory tests using Turmco15 fluid & 25 micron filter. Field results may vary by application.

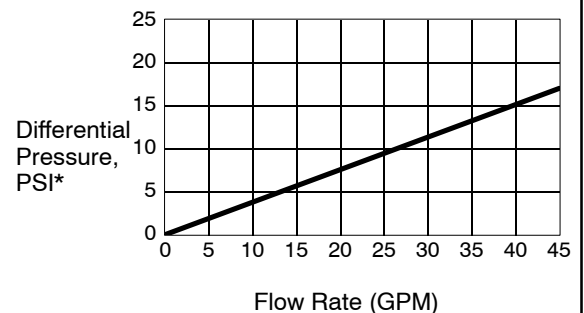

Flow Rate vs Restriction

*PSI X 2.036 = inHg. / PSI X 6.895 = kPa

Model Illustrations

No Scale

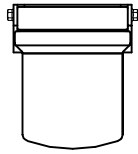

LFS 800

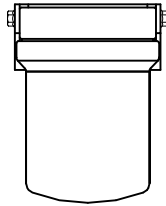

LFS 801

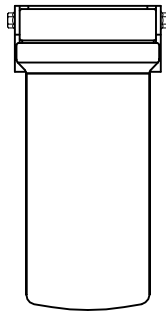

LFS 802

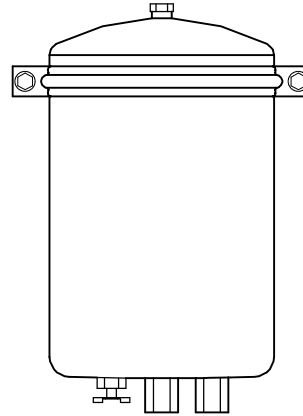

LFS 820

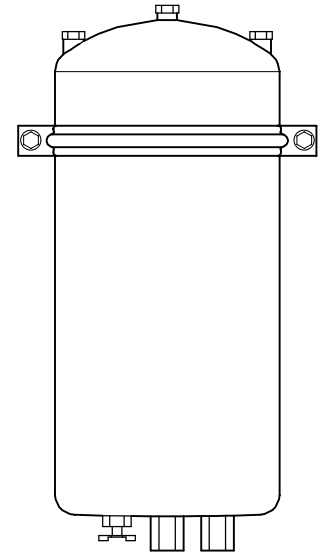

LFS 825

LFS 800 SERIES BY-PASS OIL FILTRATION SYSTEMS

Special Notes

1. Racor LFS 800 Series By-pass Oil Filtration Systems may be used with all LFS Oil Filtration Systems in this section.
2. For additional information and availability, contact customer service at: (800) 344-3286, 6 AM to 5 PM, Pacific Time.

Specifications

BASIC MODELS		LFS 800	LFS 801	LFS 802	LFS 820	LFS 825
Engine Horsepower (max.)/ Sump Cap.	Gal./LTR	150 2.5/9.5	250 5/18.9	400 15/57	500 30/114	800 45/170
Oil Flow Rate Port Size	GPM/LPM NPT	.3/.9 1/8"	.4/1.4 1/4"	.5/1.9 1/4"	1/3.8 1/2"	1.5/5.7 1/2"
Replacement Element		LFS 800BPE	LFS 801BPE	LFS 802BPE	LFS 820BPE	LFS 825BPE
Cannister Cap. Orifice Size	Gal./LTR in/mm	13/5 .040/1	.3/.9 .040/1	.5/1.9 .404/1	2.5/9.5 .093/2.4	3.5/13.3 .101/2.6
PSI, Maximum	PSI kPa	150 1034	150 1034	150 1034	150 1034	150 1034
Height	in mm	5.5 140	7.5 191	11 279	14.5 368	20 508
Width	in mm	4 102	5.25 133	5.25 133	9 229	9 229
Depth	in mm	4.5 114	5.7 145	5.7 145	9.15 233	9.15 233
Weight (dry)	Lbs kgs	3.2 1.45	5.3 2.40	8.0 3.63	13.7 6.21	18.9 8.57

Notes: 1. For accurate engine flow rates, consult your engine or equipment manual, manufacturer's agent or a Racor distributor.
 2. Oil change frequencies are not affected and should be performed according to manufacturer's recommendations.
 3. The only accredited way to extend your oil change interval is through a formal lube analysis program.

SPECIFICATIONS - See introduction page.

How to Order - See example below.

LFS	801
<u>Lubrication Filtration Systems.</u> By-pass oil filters for gas and diesel engines.	<u>Specify one by engine horsepower.</u> 800: 150 Horsepower 801: 250 Horsepower 802: 400 Horsepower 820: 500+ Horsepower 825: 800+ Horsepower

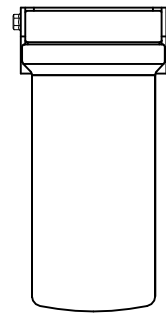

LFS 802

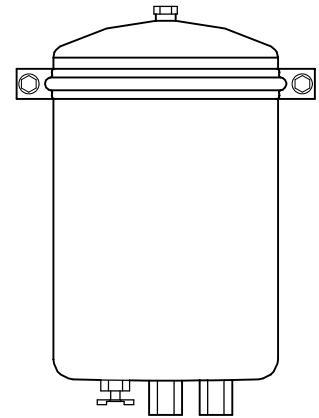

Outlet ↑ Inlet ↑
LFS 820/825

Replacement Filter Elements / Seals

Model	Part Number	Qty./case	Seal Kit No.
LFS 800	LFS 800BPE	1	LFS RK46581
LFS 801	LFS 801BPE	1	LFS RK46582
LFS 802	LFS 802BPE	1	LFS RK46582
LFS 820	LFS 820BPE	1	LFS RK46583
LFS 825	LFS 825BPE	1	LFS RK46583

General Information

Racor By-pass Oil Filtration Systems are unique in their configuration. They feature a spin-on steel canister mounted to an aluminum head. The cartridge spin-on element is made of a computer wound, cotton woven media. The engineered design of the filter element provides more efficient filtration for a significantly longer period of time than pleated cellulose, stacked discs, and other cartridge filters

When a Racor By-pass Oil Filter is installed with a Racor Full Flow Lubrication Filtration System (LFS), the cost of lube oil, replacement filter, related disposal and maintenance are drastically reduced.

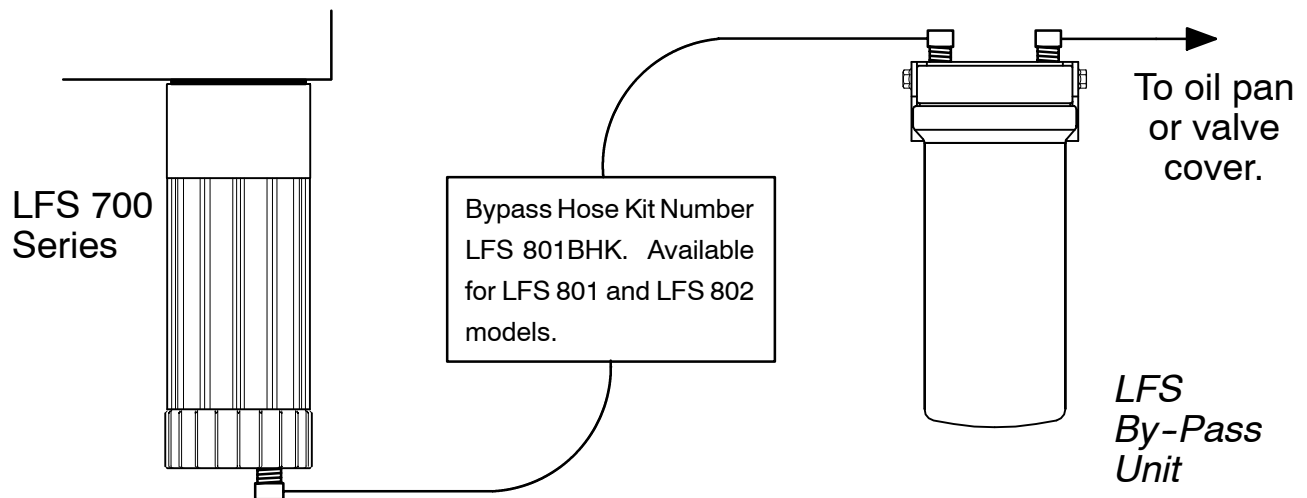

Fluid By-pass Sensor Switch Kits

Kit Part No.	Description / Notes	Use with:	Qty.
LFS RK356LS	Standard By-pass Sensor Switch <i>Do not use above kits when filtering gasoline or other volatile fluids.</i>	LFS35, 55 & 60	1
LFS RK46138	By-pass Sensor Switch <i>Do not use above kits when filtering gasoline or other volatile fluids.</i>	LFS92	1
LFS RK760	Oil Analysis Kit <i>Use this kit to determine extended oil change intervals while using our By-Pass filtration units.</i>	All Models	1

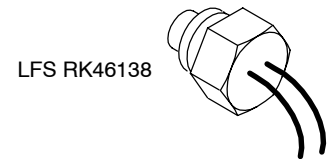

Light Display Kits

Kit Part No.	Description / Notes	Use with:	Qty.
LFS RK356LSK	Complete By-pass Light Display Kit Includes By-pass Sensor also. 12 vdc.	LFS35, 55, 62 & 64	1
46032	By-pass Light Display only. 12 vdc.	LFS 92, 700 Series	1
46536	Connector Assembly with Relay (not shown)	LFS 700 Series	1
LFS RK46134	In-dash Light Display, 12 / 24 vdc. Informs the operator when filter servicing is required. Features a 10 min. timed delay to eliminate false readings. Light stays on until filter is serviced. Panel press-to-test buttons. Fits 2" diameter openings. Includes bracket for underdash mounting also. Order By-pass Sensor Switch separately (see above).	LFS35, 62, 64, & 92	1

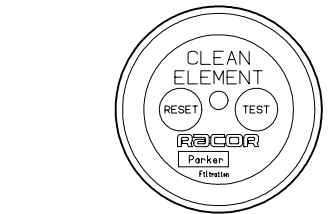
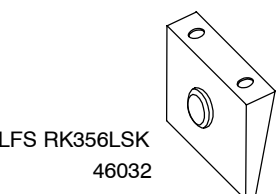

Do not use above kits when filtering gasoline or other volatile fluids.

Spin-on Oil Filter Adapter & Replacement O-ring Kits

Complete Kit Part No.	*Replacement Seal kit Part No.	Adapter to engine threads	Adapter in/out port threads	(O'berg No.)
LFS CHV-A	N/A	1/4"-20 (2)5/16"-18(2)	1/2"-14 NPTF	233
LFS 112-36A	RK 46169	1"-12	1/2"-14 NPTF	214
LFS 11212-48A	RK 46045	1 1/2"-12	1 5/16"-12 SAE	212
LFS 11216-41A	RK 46170	1 1/2"-16	1/2"-14 NPTF	269
LFS 11216-48A	RK 46045	1 1/2"-16	1 5/16"-12 SAE	219
LFS 11216-50A	N/A	1 1/2"-16	1 5/16"-12 SAE	247
LFS 116-36A	RK 46169	1"-16	1/2"-14 NPTF	252
LFS 11816-36A	RK 46169	1 1/8"-16	1/2"-14 NPTF	225
LFS 11816-48A	RK 46045	1 1/8"-16	1 5/16"-12 SAE	218
LFS 1316-36A	RK 46169	13/16"-16	1/2"-14 NPTF	222
LFS 13816-48A	RK 46045	1 3/8"-16	1 5/16"-12 SAE	210
LFS 15812-48A	RK 46045	1 5/8"-12	1 5/16"-12 SAE	N/A
LFS 1815-31A	RK 46169	18 mm X 1.5	1/2"-14 NPTF	250
LFS 2015-31A**	RK 46169	20 mm X 1.5	1/2"-14 NPTF	232
LFS 2015-36A	RK 46169	20 mm X 1.5	1/2"-14 NPTF	231
LFS 2215-31A	RK 46169	22 mm X 1.5	1/2"-14 NPTF	223
LFS 3416-31A	RK 46169	3/4"-16	1/2"-14 NPTF	213
LFS 5818-31A	RK 46169	5/8"-18	1/2"-14 NPTF	251

TYPICAL ADAPTER
Kits include seal.

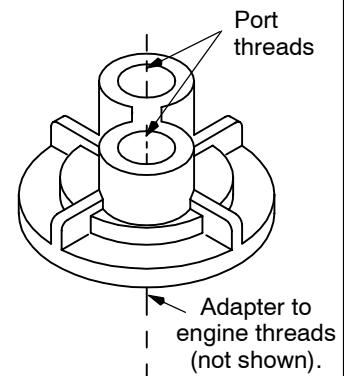

*O-ring or gasket also available as a replacement.

*O-ring or gasket should be replaced if adapter is removed from engine, after being in service.
 RK 46169: Gasket, 2.48" I.D. RK 46045: O-ring, 3.73" I.D. RK 46170: Gasket, 3.10" I.D.
 **Includes a spacer plate.

Heavy Duty Hose and Fittings Kits

LFS 35 AND 55: KIT No. LFS 35HK

Includes

Medium pressure hose, SAE100R5 (Parker #201-6) (May be cut to desired length)	Qty. 8 feet
Straight fitting adapter, 3/8" NPT to #6 JIC (Parker #6-6FTX)	2
Straight fitting adapter, 1/2" NPT to #6 JIC (Parker #6-8FTX)	2
Swivel fitting, Hose to #6 JIC (Parker #20620-6-6)	4

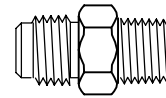

Straight Fitting Adapter
NPT x JIC

LFS 62 / 64: KIT No. LFS 60HK

Medium pressure hose, SAE100R5 (Parker #201-12) (May be cut to desired length)	8 feet
Straight fitting adapter, 1 1/16" SAE to #12 JIC (Parker #12F50X)	2
Straight fitting adapter, 1/2" NPT to #12 JIC (Parker #12-8FTX)	2
Swivel fitting, Hose to #12 JIC (Parker #20620-12-12)	4

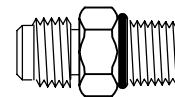

Straight Fitting Adapter
SAE x JIC

LFS 92: KIT No. LFS 90HK

Medium pressure hose, SAE100R5 (Parker #201-16) (May be cut to desired length)	8 feet
Straight fitting adapter, 1 5/16" SAE to #16 JIC (Parker #16F50X)	4
Swivel fitting, Hose to #16 JIC (Parker #20620-16-16)	4

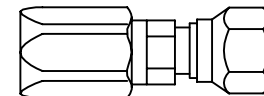

Swivel Hose Fitting
Hose to JIC

ACCESSORIES FOR LFS 62 & 92 BY-PASS UNITS:

LFS RK46153-01

Tee fitting for LFS 92BP. Qty. 1

LFS RK46153-02

Tee fitting for LFS 62BP. Qty. 1

LFS RK46159

Hose kit for LFS 62BP and LFS 92BP. Qty. 1

46117

Fitting for LFS 62/64BP models. Reduces port to 3/8" NPT. Qty. 1

ACCESSORIES FOR LFS 700 SERIES:

LFS RK46588, Quick Fill Coupling, male 9/16-18 SAE thread. Qty. 1

LFS RK46589, Adapter Coupling, female 1/4-18 NPT thread. Qty. 1

LFS RK46590, Test Port Coupling, male 1/8-27 NPT thread. Qty. 1

Multi-Filter Kits

LFS 62 / 64:

KIT No. LFS RK60MFK

Includes:

Multi-filter adapter plate	Qty. 1
Extended Length Studs	4
LFS 6060WCF Filter Screen	1

LFS 92:

KIT No. LFS RK90MFK

Includes:

Multi-filter adapter plate	Qty. 1
Extended Length Studs	4
LFS 9060WCF Filter Screen	1

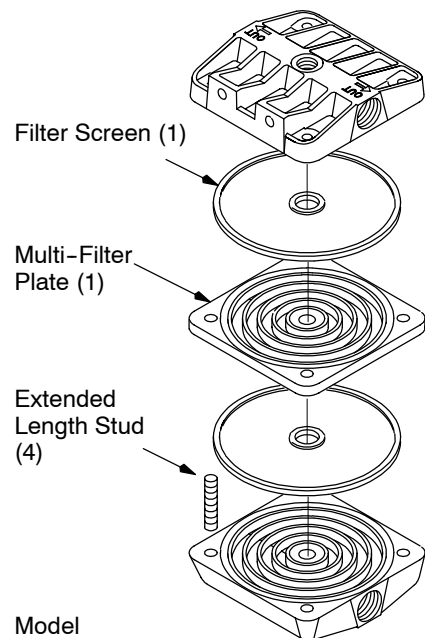

Model
LFS 64 shown

Quick Help Guide: All Models

ALL RACOR LFS MODELS ARE 100% TESTED TO ENSURE A LEAK-PROOF, QUALITY PRODUCT.

In the event difficulties are experienced with your unit review the following most common questions asked about the LFS units:

WARNING LAMP REMAINS ILLUMINATED:

Q. What causes the warning lamp on the LFS 35, 55, 62, 64, 92, 94, and 700LS Series to stay on and not go off?

A. This lamp indicates that the filter screen is dirty. On initial installations, the screen may appear to clog in a rather short time. This is normal for the first few 'clean-up' cycles. Thereafter, the frequency should stabilize and occur less often. If the lamp stays on after a cleaning, investigate the following:

LFS 35, 55, 62, 64, 92, and 94: With the filter halves separated and power supplied to the light switch, depress and release the by-pass mechanism. The light should be on when the by-pass is pushed down and go out when released. If the light switch does not function as indicated above, it will have to be replaced.

Note: It is important that the clear plastic insulator gasket between the switch and filter body be used and not distorted due to over tightening of the switch. If this gasket is missing, the warning lamp will stay on.

LFS 700LS Series: The LFS 700 Series light switch is normally closed when the light is off. If the lamp is illuminated, there are several possible reasons: the filter is dirty, there is an open circuit in the endcap, there is an open circuit in the connector plug, the connector plug is disconnected, there is an open circuit between the endcap and the relay, or there is a bad relay.

WARNING LAMP FLICKERS ON/OFF WHEN ENGINE IS FIRST STARTED:

Q. What causes the lamp to flicker on and off when I first start the engine?

A. This will sometimes happen on a cold morning due to the thicker viscosity of the oil. Pushing cold oil through the element can build up enough pressure against the by-pass to cause the light to try to come on. The original equipment oil filter that you replaced when installing the LFS creates nearly twice the back pressure and generally goes into complete by-pass under these conditions. Only Racor's LFS is sensitive enough to indicate this insignificant amount of by-pass. The lamp must remain fully illuminated before a serious by-pass occurs.

FILTER CONTAMINATION:

Q. When I open the filter it appears clean but the bottom side of it is full of particulates and debris.

A. This filter is plumbed backwards so the contaminants are on the 'wrong' side. If this happens, the unit will continue to filter until plugged and then it will hold the by-pass valve closed, and will not allow the light to come on. This will stop oil flow to the engine unless there is a built-in, by-pass relief valve in the engine. The Racor engine spin-on filter adapter replacements are marked IN and OUT or have arrows indicating flow direction. The LFS oil filter housings are also clearly marked IN and OUT or have arrows indicating flow direction.

*NOTE: Do not match IN to IN or OUT to OUT! Remember the oil flows **out** from the engine and **in** to the filter. Then, it flows **out** of the filter and back **into** the engine.*

Q. How do I determine which filter to use for a given application?

A. Refer to the LFS application guide for remote mount units, the adapter part number and recommended filter size will be listed. If you have a non listed or specialized application, size the filter by flow rate capacity and the adapter by comparing the OEM specification for thread and gasket dimensions. The flow rate specs for each filter are listed the the 7460 brochure and in this parts book.

The application guide for the cleanable Spin-on 700LS Series is on page 221.

For additional assistance, call your Racor Dealer or Racor Customer Service at (209) 521-7860 or (800) 344-3286, 6 AM to 5 PM, Pacific Time, or e-mail us from our website, www.parker.com/racor.

Racor Products

Section 6 Alternative Fuels

- Selection
- Introduction
- FFC-110/110L
- FFC-112/112SAE
- FFC-113
- FFC-114
- FFC-115
- FFC-116
- FFC-119



Help & General
Information

General

Racor Alternative Fuel Filtration products are designed to protect critical engine components in compressed natural gas (CNG), liquid natural gas (LNG) and liquid propane gas (LPG) powered vehicles. Contaminants can be introduced into the vehicle's fuel tank when being fueled. Contaminants may come from CNG compressors and storage facilities. These units are specifically designed to remove oil, water and solid contamination from compressed natural gas. The special coalescing filters remove over 95% of all aerosols in the 0.3 to 0.6 micron range.

1. DETERMINE THE ALTERNATE FUEL TO BE FILTERED: CNG, LNG OR LPG.
2. DETERMINE THE SYSTEM PRESSURE FOR THE MOUNTING LOCATION.
The pressure may be found by contacting the vehicle or engine manufacturer.
To convert kilopascals (kPa) to PSI, divide kPa by 6.8947.
3. DETERMINE THE SYSTEM FLOW RATE IN SCFM*.
The flow rate may be found by contacting the vehicle or engine manufacturer.
**(Standard Cubic Feet per Minute or SCFM, calculated at 100 PSIG).
To convert liters per minute (LPM) to SCFM, multiply LPM by .0353).
To convert pounds per hour (PPH) to SCFM, divide PPH by 60 and then divide by .0447.*

Using this information, select a unit for service from this page that suits your application and fits within installation size limitations (if any).

Alternative Fuel Filtration Systems

Model Illustrations

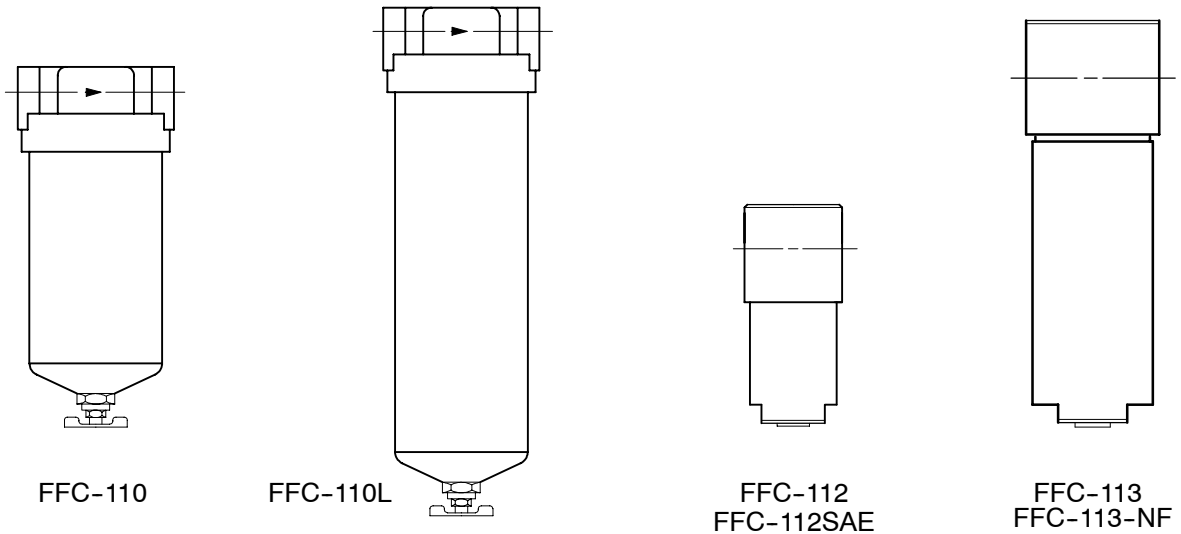

Special Notes

1. TO SELECT THE RIGHT FILTER FOR YOUR APPLICATION, SEE THE PREVIOUS PAGE.
2. The Model FFC-112 is Listed in accordance with AGA1-85 by the American Gas Association Laboratories.
3. For additional information, contact customer service at: (800) 344-3286, 6 AM to 5 PM, Pacific Time.

Specifications

Model FFC-112 is
American Gas Association
Laboratories Listed

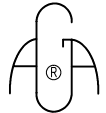

BASIC MODELS		FFC-110	FFC-110L	FFC-112	FFC-112-SAE	FFC-113
Fuels		CNG, LPG	CNG, LNG, LPG	CNG	CNG	CNG, LNG
Filter Type		Coalescer	Coalescer	Coalescer	Coalescer	Coalescer
Operating Pressure, Max.	PSI kPa	500 3,447	500 3,447	3,600 24,800	3,600 24,800	3,600 24,800
Maximum Flow Rate	SCFM lpm	25 708	50 1,416	15 425	15 425	50 1,416
Port Size, NPT (SAEJ476)		1/4" NPT	1/2" NPT	1/4" NPT	9/16"-18 SAE	1/2" NPT
Filter Element		CLS110-10	CLS110-10L	CLS112-10	CLS112-10	CLS113-6
Length	in. mm	7.16 182	10.40 264	4.75 121	4.75 121	8.03 204
Diameter	in. mm	3.13 80	3.13 80	2.25 57	2.25 57	2.97 75
Weight (dry)	Lbs. kgs.	1.5 0.68	1.8 0.82	1.5 0.68	1.5 0.68	5.5 2.49
Clean Pressure Drop	PSID kPa	1.00 6.9	1.00 6.9	3.0 20.7	3.0 20.7	1.7 11.7
Sump Capacity	ounces cc's	5.0 148	7.0 207	0.5 15	0.5 15	5.0 148
Operating Temperature		-40° / +225° F / -40° / +107° C				

1. For accurate flow rates and pressures consult your engine manual, engine manufacturer's agent or the vehicle manufacturer.

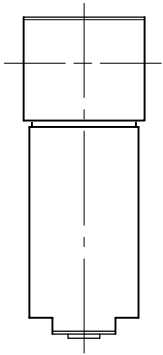

FFC-114
FFC-114-NF

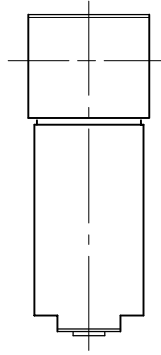

FFC-115

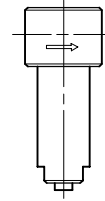

FFC-116

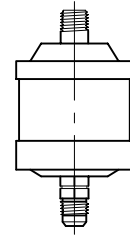

FFC-119

Specifications - continued

BASIC MODELS		FFC-113-NF	FFC-114	FFC-114-NF	FFC-115	FFC-116	FFC-119
Fuels		CNG, LNG	CNG, LPG	CNG, LPG	LNG	CNG	LPG
Filter Type		Coalescer	Coalescer	Coalescer	Coalescer	Coalescer	Prefilter/strainer
Operating Pressure, Max.	PSI kPa	3,600 24,800	3,600 24,800	3,600 24,800	3,600 24,800	5,000 34,480	500 3,447
Maximum Flow Rate	SCFM lpm	50 1,416	50 1,416	50 1,416	60 1,700	8.4 238	N/A
Port Size, NPT (SAEJ476)		3/4" SAE	1/2" NPT	3/4" SAE	1" NPT	1/4" NPT	1/4" NPT 5/8" outlet
Filter Element		CLS113-6	CLS113-6	CLS113-6	CLS113-6	CLS116-10	N/A
Length	in. mm	8.03 204	6.98 177	6.98 177	6.98 177	3.85 97	4.87 124
Diameter	in. mm	2.97 75	2.97 75	2.97 75	3.15 80	1.75 44	2.63 67
Weight (dry)	Lbs. kgs.	5.5 2.49	5.25 2.3	5.25 2.3	6.0 2.7	1.75 0.79	0.5 0.23
Clean Pressure Drop	PSID kPa	1.7 11.7	1.7 11.7	1.7 11.7	1.7 11.7	1.25 8.6	N/A
Sump Capacity	ounces cc's	5.0 148	3.0 88	3.0 88	3.0 88	0.25 7.4	N/A
Operating Temperature		-40° / +225° F / -40° / +107° C					

1. For accurate flow rates and pressures consult your engine manual, engine manufacturer's agent or the vehicle manufacturer.
2. Some specifications are the result of tests conducted at the optimum flow rate.

SPECIFICATIONS are found on Alternative Fuel Filtration introduction page.

FFC-110	FEATURES
<p>FFC-110: 25 SCFM/500 PSI Coalescer. Black powder coating on 380 aluminum head and 6061 cannister with standard 1/4" NPTF ports and standard Grade 10 element.</p> <p>FFC-110L: 50 SCFM/500 PSI</p>	<ul style="list-style-type: none"> - For use with CNG, LPG (FCC-110L: also LNG). - Durable construction and simple servicing. - Small size allows for installation versatility. - Patented filter removes over 95% of all aerosols in the 0.3 to 0.6 micron range. - FFC-110 sump capacity = 5 oz. (148 cc) FFC-110L sump capacity = 7.0 oz. (207 cc) of fluid contaminants. - Assemblies are powder painted for long term corrosion protection.

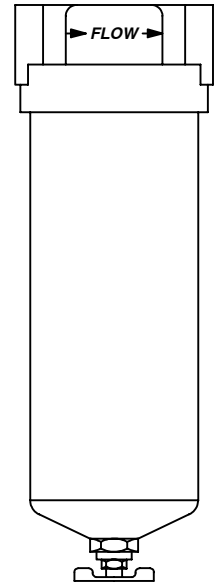

FFC-110L

Replacement Coalescing Service Elements

FFC-110		FFC-110L	
CLS110-04	Grade 4, element	CLS110L-04	Grade 4, element
CLS110-3M	3 micron element	CLS110L-3M	3 micron element
CLS110-06	Grade 6, element	CLS110L-06	Grade 6, element
CLS110-10	Grade 10, element	CLS110L-10	Grade 10, element

Installation Diagram / Dimensional Layout

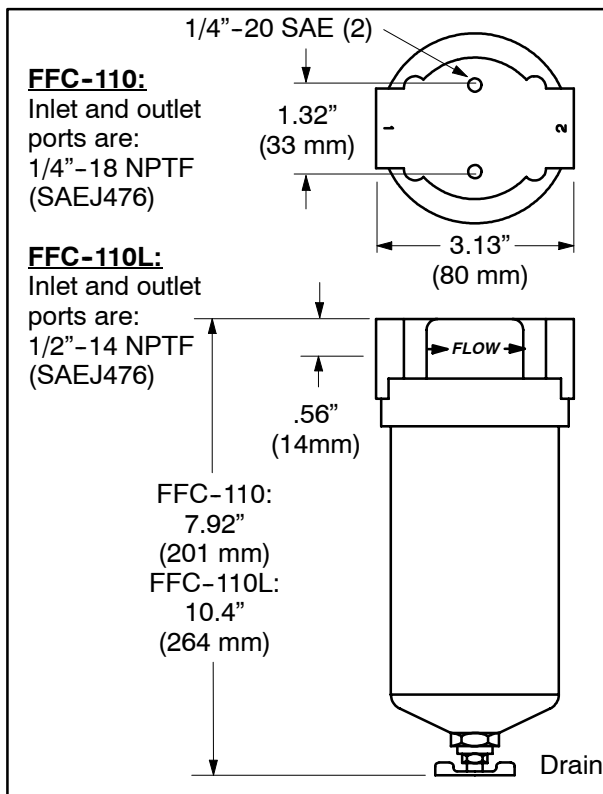
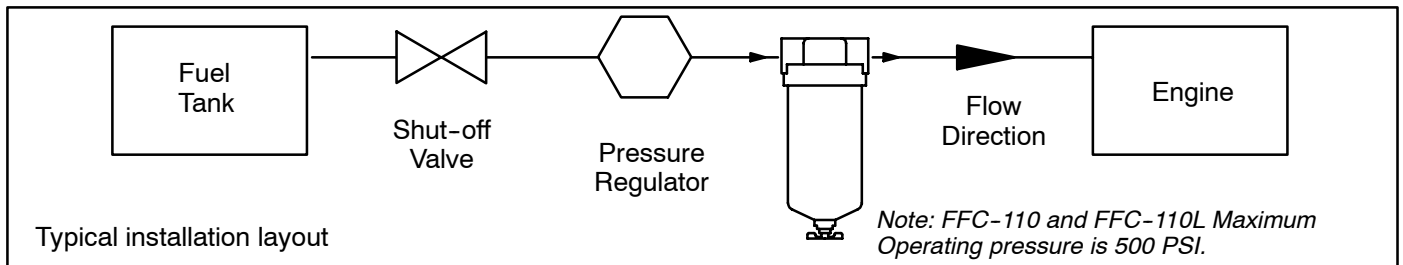

Installation Note

The unit should be located in an accessible and protected location for easy servicing. Use connectors approved by the American Gas Association and the Department of Transportation. Test the installation for leaks using an approved leak detection fluid.

Service Note Caution:

The unit must not be under pressure during servicing. Injury to personnel may result. Close the shut-off valve shown in the illustration above and slowly relieve line pressure before attempting service.

Replacing the Element

Change the element at the same time as engine oil filter changes or at least every 3,000 miles.

Draining the Housing

Drain the housing every 1,500 miles or as necessary. With line pressure relieved, open valve and drain until liquid is removed, then close the valve.

SPECIFICATIONS are found on Alternative Fuel Filtration introduction page.

FFC-112	FEATURES
<p>FFC-112: 15 SCFM/3,600 PSI, Coalescer. Black anodized coating on 6061-T6 aluminum head and cannister with standard 1/4" NPTF ports and Grade 10 element.</p> <p>FFC-112-SAE: 9/16"-18 SAE ports.</p>	<ul style="list-style-type: none"> - For use with CNG systems. - Listed with the American Gas Association. - Durable construction and simple servicing. - Small size allows for installation versatility. - Patented filter removes over 95% of all aerosols in the 0.3 to 0.6 micron range. - Sump capacity up to .5 oz. (15 cc) of contaminants. - Maximum burst pressure of 15,000 PSI.

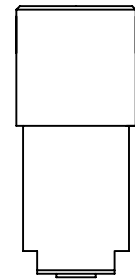

FFC-112
FFC-112-SAE

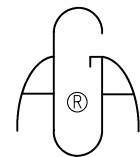

American Gas Association
Laboratories Listed

Replacement Service Element

CLS112-10	Grade 10, coalescing service element
------------------	--------------------------------------

Installation Diagram / Dimensional Layout

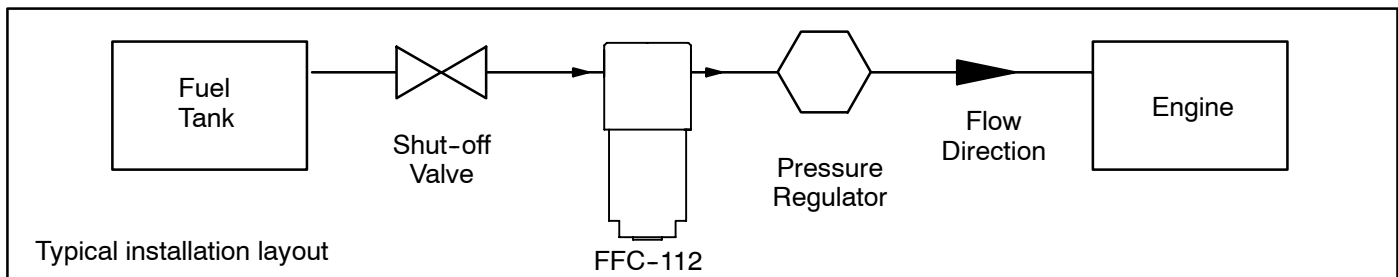

FFC-112:
Head is 2.25" (57 mm) diameter.
Inlet and outlet ports are: 1/4"-18 NPTF (SAEJ476)

FFC-112-SAE:
Inlet and outlet ports are: 9/16"-18 SAE O-ring ports (SAEJ1926)

Maintain at least 3" (76 mm) of clearance below the unit for element access.

Installation Note
The unit should be located in an accessible and protected location for easy servicing. Use connectors approved by the American Gas Association and the Department of Transportation. Maintain at least 3" (76 mm) of clearance below the unit for element access. Test the installation for leaks using an approved leak detection fluid.

Service Note Caution:
The unit must not be under pressure during servicing. Injury to personnel may result. Close the shut-off valve shown in the illustration above and slowly relieve line pressure before attempting service.

Replacing the Element
Change the element at the same time as engine oil filter changes or at least every 3,000 miles.

Draining the Housing
Drain the housing every 1,500 miles or as necessary. With line pressure relieved, remove the drain plug using a 1/4" Allen wrench, then replace the plug.

SPECIFICATIONS are found on Alternative Fuel Filtration introduction page.

FFC-113	FEATURES
<p>Basic Model 50 SCFM/3,600 PSI Coalescer. 303 stainless steel construction with standard 1/2" NPTF ports and Grade 6 element. FFC-113-NF is standard with 3/4" SAE ports.</p>	<ul style="list-style-type: none"> - For use with CNG and medium flow LNG systems. - Durable construction and simple servicing. - Small size allows for installation versatility. - Patented filter removes over 95% of all aerosols in the 0.3 to 0.6 micron range. - Sump capacity up to 5 oz. (148 cc) of fluid contaminants. - By-pass feature allows continuous operation to prevent increased system restriction.

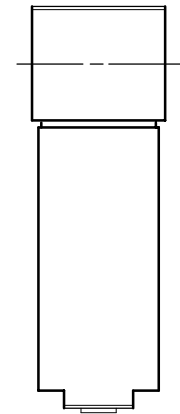

Replacement Service Element

CLS113-6 Grade 6, coalescing service element

FFC-113
FFC-113-NF

Installation Diagram / Dimensional Layout

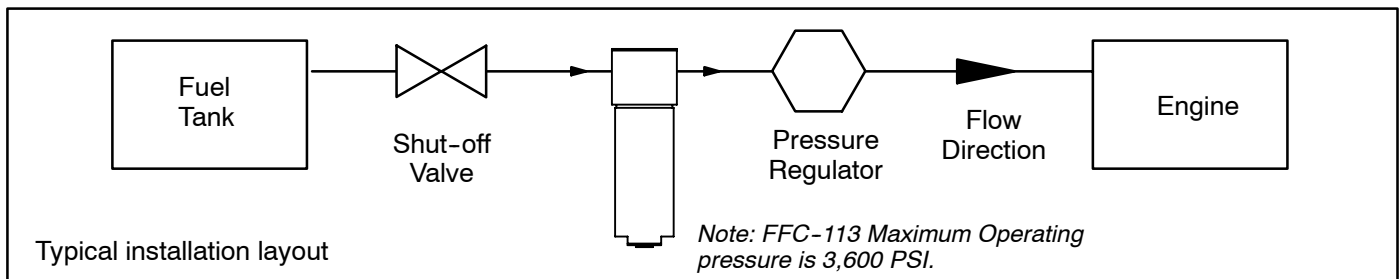

FFC-113
 Head is 2.97" (75 mm) diameter.
 Inlet and Outlet ports are: 1/2"-14 NPTF (SAEJ476)

FFC-113-NF
 Head is 2.97" (75 mm) diameter.
 Inlet and Outlet ports are: 3/4" SAE

Installation Note
 The unit should be located in an accessible and protected location for easy servicing. Use connectors approved by the American Gas Association and the Department of Transportation. Test the installation for leaks using an approved leak detection fluid.

Service Note Caution:
 The unit must not be under pressure during servicing. Injury to personnel may result. Close the shut-off valve shown in the illustration above and slowly relieve line pressure before attempting service.

Replacing the Element
 Change the element at the same time as engine oil filter changes or at least every 3,000 miles.

Draining the Housing
 Drain the housing every 1,500 miles or as necessary. With line pressure relieved, open valve and drain until liquid is removed, then close the valve.

SPECIFICATIONS are found on Alternative Fuel Filtration introduction page.

FFC-114	FEATURES
<p>Basic Model 50 SCFM/3,600 PSI Coalescer. 303 stainless steel construction with standard 1/2" NPTF ports and Grade 6 element. FFC-114-NF is standard with 3/4" SAE ports.</p>	<ul style="list-style-type: none"> - For use with CNG and medium flow LPG systems. - Durable construction and simple servicing. - Small size allows for installation versatility. - Patented filter removes over 95% of all aerosols in the 0.3 to 0.6 micron range. - Sump capacity up to 3 oz. (88 cc) of fluid contaminants. - Stainless steel for superior corrosion resistance. - By-pass feature allows continuous operation to prevent increased system restriction.

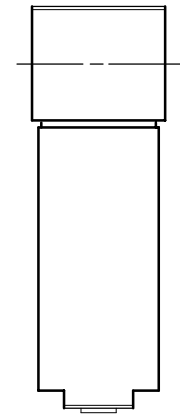

FFC-114
FFC-114-NF

Replacement Service Element

CLS113-6 Grade 6, coalescing service element

Installation Diagram / Dimensional Layout

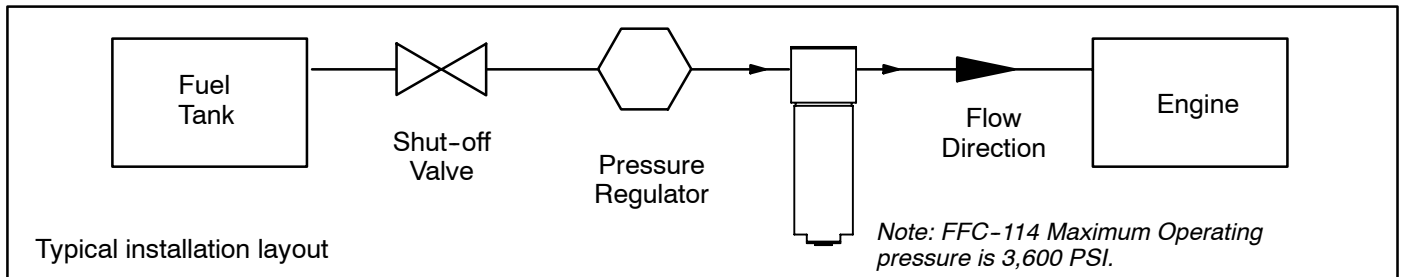

Typical installation layout

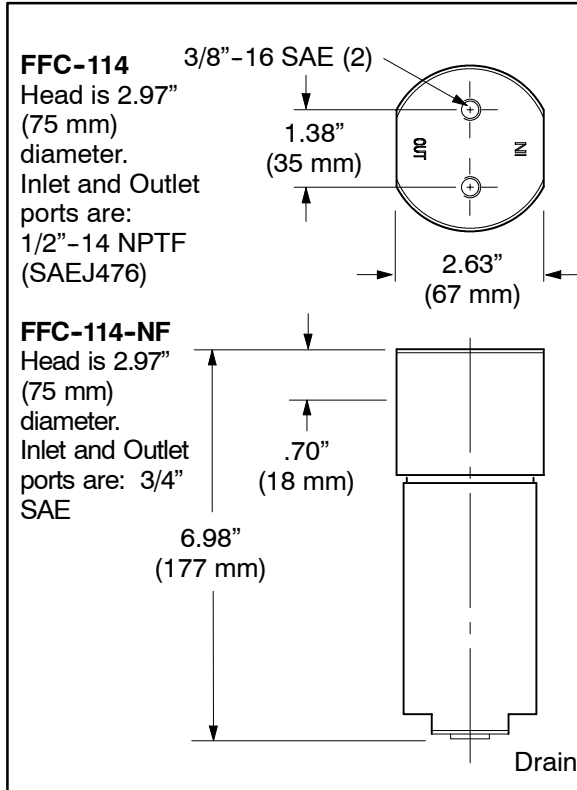

Installation Note

The unit should be located in an accessible and protected location for easy servicing. Use connectors approved by the American Gas Association and the Department of Transportation. Test the installation for leaks using an approved leak detection fluid.

Service Note Caution:

The unit must not be under pressure during servicing. Injury to personnel may result. Close the shut-off valve shown in the illustration above and slowly relieve line pressure before attempting service.

Replacing the Element

Change the element at the same time as engine oil filter changes or at least every 3,000 miles.

Draining the Housing

Drain the housing every 1,500 miles or as necessary. With line pressure relieved, open valve and drain until liquid is removed, then close the valve.

SPECIFICATIONS are found on Alternative Fuel Filtration introduction page.

FFC-115	FEATURES
<p><u>Basic Model</u> 60 SCFM/3,600 PSI Coalescer. 303 stainless steel construction with standard 1" NPTF ports and Grade 6 element.</p>	<ul style="list-style-type: none"> - For use with medium to high flow rate LNG systems. - Durable construction and simple servicing. - Small size allows for installation versatility. - Patented filter removes over 95% of all aerosols in the 0.3 to 0.6 micron range. - Sump capacity up to 3 oz. (88 cc) of fluid contaminants. - Assembly is stainless steel for long term corrosion resistance. - By-pass feature allows continuous operation to prevent increased system restriction.

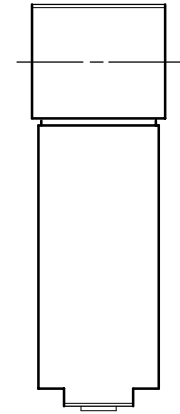

FFC-115

Replacement Service Element

CLS113-6 Grade 6, coalescing service element

Installation Diagram / Dimensional Layout

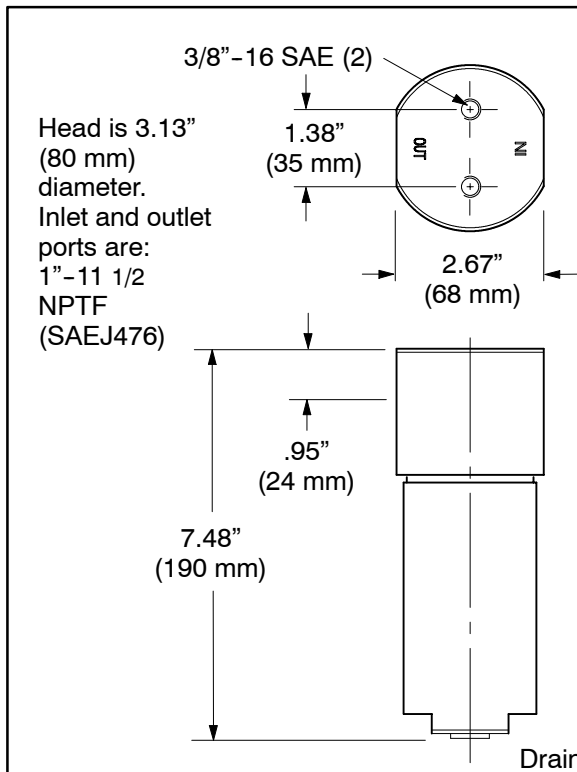
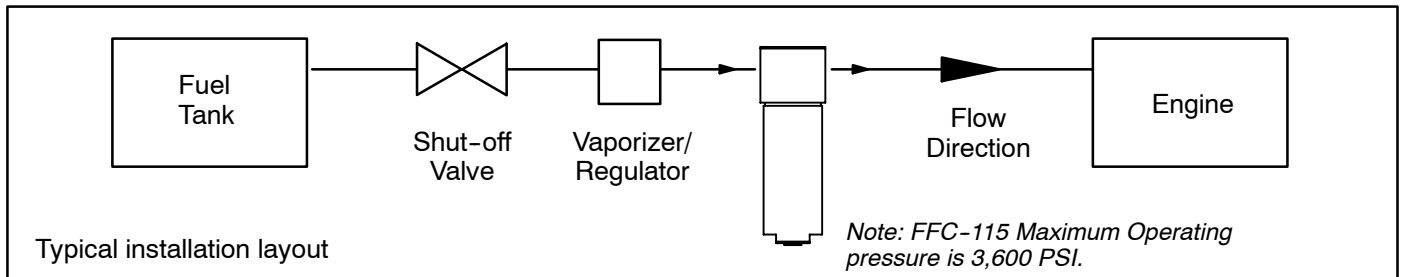

Installation Note

The unit should be located in an accessible and protected location for easy servicing. Use connectors approved by the American Gas Association and the Department of Transportation. Test the installation for leaks using an approved leak detection fluid.

Service Note Caution:

The unit must not be under pressure during servicing. Injury to personnel may result. Close the shut-off valve shown in the illustration above and slowly relieve line pressure before attempting service.

Replacing the Element

Change the element at the same time as engine oil filter changes or at least every 6,000 miles.

Draining the Housing

Drain the housing every 2,000 miles or as necessary. With line pressure relieved, open valve and drain until liquid is removed, then close the valve.

SPECIFICATIONS are found on Alternative Fuel Filtration introduction page.

FFC-116	FEATURES
<p><u>Basic Model</u> 8.4 SCFM/5,000 PSI Coalescer. 316 stainless steel construction with standard 1/4" NPTF ports and Grade 10 element.</p>	<ul style="list-style-type: none"> - For use with low flow CNG systems. - Durable construction and simple servicing. - Small size allows for installation versatility. - Patented filter removes over 95% of all aerosols in the 0.3 to 0.6 micron range. - Sump capacity up to .25 oz. (7.4 cc) of fluid contaminants.

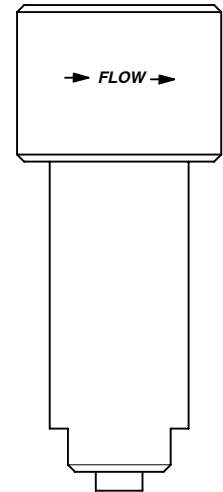

FFC-116

Replacement Service Element

CLS116-10	Grade 10, coalescing service element
------------------	--------------------------------------

Installation Diagram / Dimensional Layout

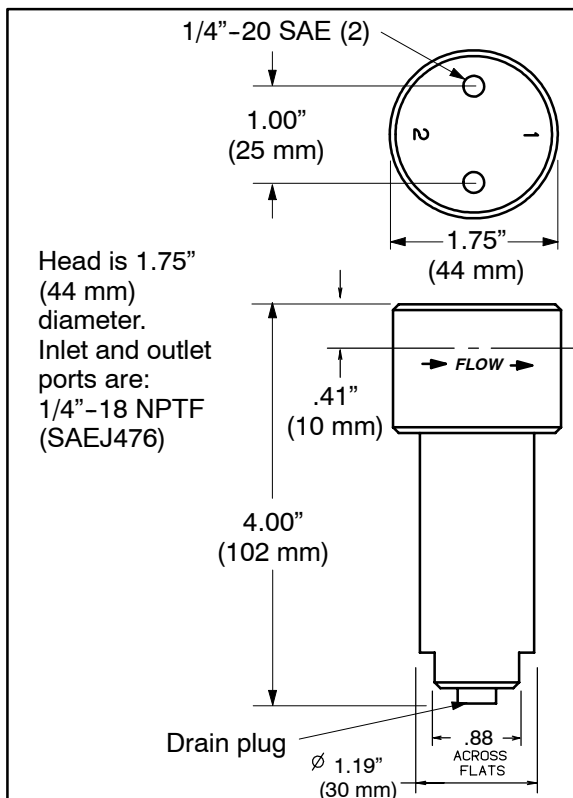
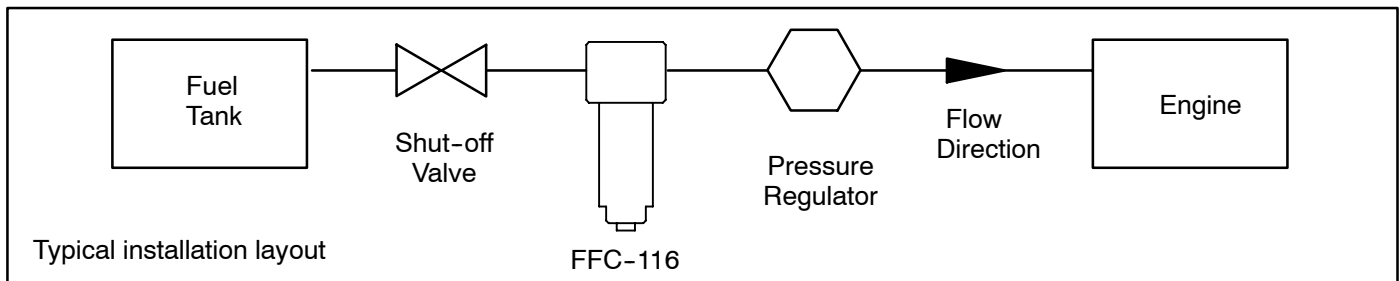

Installation Note

The unit should be located in an accessible and protected location for easy servicing. Use connectors approved by the American Gas Association and the Department of Transportation. Test the installation for leaks using an approved leak detection fluid.

Service Note Caution:

The unit must not be under pressure during servicing. Injury to personnel may result. Close the shut-off valve shown in the illustration above and slowly relieve line pressure before attempting service.

Replacing the Element

Change the element at the same time as engine oil filter changes or at least every 3,000 miles.

Draining the Housing

Drain the housing every 1,500 miles or as necessary. With line pressure relieved, remove the drain plug using a 1/4" Allen wrench, then replace the plug.

SPECIFICATIONS are found on Alternative Fuel Filtration introduction page.

FFC-119	FEATURES
<p><u>Basic Model</u> 500 PSI Prefilter/Strainer. Painted steel construction.</p>	<ul style="list-style-type: none"> - For use with LPG systems. - Durable construction. - Small size allows for installation versatility. - Assembly is painted for long term corrosion resistance.

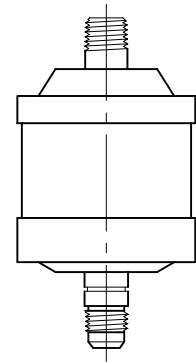

FFC-119

Replacement Service Element

No Service Element Available

Installation Diagram / Dimensional Layout

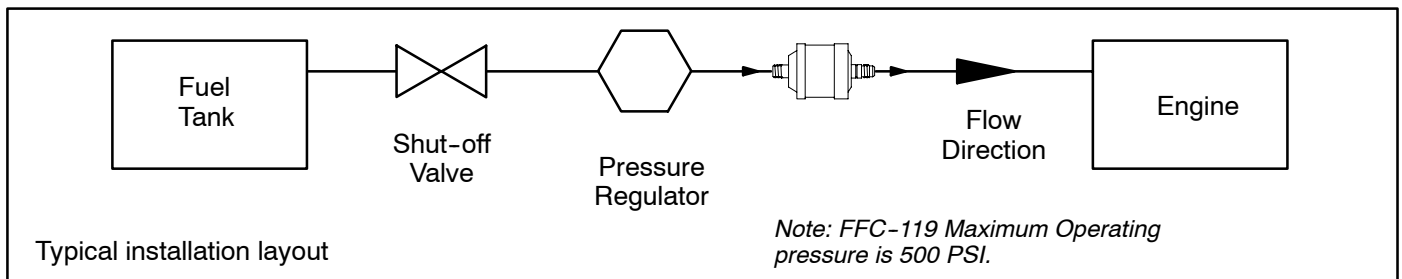

Body is 2.63" (67 mm) diameter.
Inlet port is 1/4"-18 NPTF male (SAEJ476).

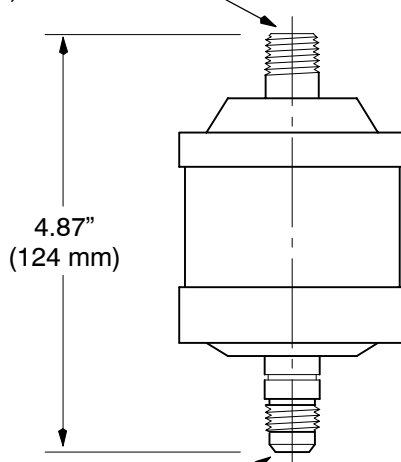

Outlet port is 5/8"-18 UNF-2A SAE 45° Flare (SAEJ512).

Installation Note

The unit should be located in an accessible and protected location for easy servicing. Use connectors approved by the American Gas Association and the Department of Transportation. Test the installation for leaks using an approved leak detection fluid.

Service Note Caution:

The unit must not be under pressure during servicing. Injury to personnel may result. Close the shut-off valve shown in the illustration above and slowly relieve line pressure before attempting service.

Replacing the Element

Change the element at the same time as engine oil filter changes or at least every 3,000 miles.

Racor Products

Section 7 Crankcase Ventilation Systems

- Selection
- CV Products
- CV820
- CV1000
- CCV Products
- CCV4500
- CCV6000
- CCV8000
- Accessories



Crankcase Filtration Systems

Model	Engine Horsepower Range	Unit Capacity in Cubic Feet/Min.	Page
CV 820	0-350	10	247-248
CV 1000	350-600	15	247, 249
CV 1000-2X	600-1200	30	247, 250
CCV4500	0-400	10	251-252
CCV6000	400-800	20	251, 253
CCV8000	800-1600	40	251, 254
Accessories			256-257
Discontinued Models			258

Model Illustrations

CV Style for Open Systems

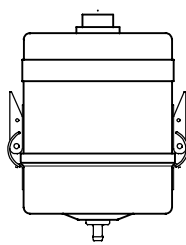

CV820

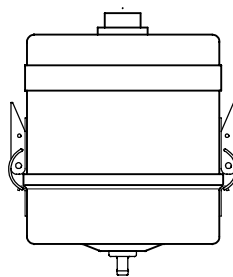

CV1000

Special Notes

1. For additional information and availability, contact customer service at: (800) 344-3286, 6 AM to 5 PM, Pacific Time.
2. CV units are for Open System applications only.

Specifications

BASIC MODELS		CV820	CV1000
Engine Horsepower	HP	0-350	350-600
Rating, Max.	KW	0-260	260-450
Inlet Port Size		1" NPT	1 1/4" NPT
Outlet Port Size		1" NPT	1 1/4" NPT
Max. Air Flow*	CFM	10	15
	L/s	4.72	7.08
Filter Element		CV820SK	CV1000SK
Height	in.	7.55	8.48
	mm	192	215
Diameter (depth)	in.	6.00	8.14
	mm	152	207
Weight (dry)	Lbs.	2.0	3.0
	kgs.	0.9	1.4
Sump Capacity:	fl. oz.	32	58
	ml.	946	1720
Operating Temperature		-40° / +255° F / -40° / +121° C	

* Values given are cubic feet per minute (CFM) and liters per second (L/s).

1. For horsepower rating consult your engine manual, engine manufacturer's agent or a Racor distributor.

SPECIFICATIONS are found on *Emission Control Systems* introduction page.

CV820	FEATURES
<p><u>Basic Model</u> For 0-350 Horsepower rated engines. Unit flow capacity is 10 CFM.</p>	<ul style="list-style-type: none"> - For use with open systems only. - Durable construction. - Compact size allows for installation versatility. - Replaceable filter media. - Removable oil collection sump. Assembly is black anodized for long term corrosion resistance.

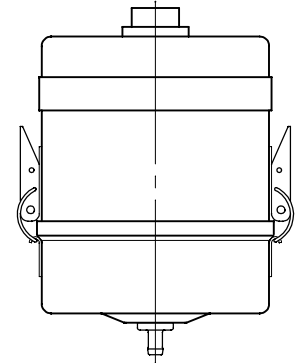

CV820

Replacement Service Element

<p>CV820SK Service element, includes housing gasket</p>
--

Installation Diagram / Dimensional Layout

Top View

Body is 6.00" (152 mm) diameter.
Either port may be Inlet / outlet:
1"-11 1/2 NPT female (SAEJ476).

Typical Open System installation. No scale.

.33" (8 mm) clearance required for fasteners.

3.35" (85 mm)

Quick release clamps retain collection sump.

Drain valve

Service:
On units that do not return the oil to the crankcase, check or drain the sump frequently until a routine service interval is established.

Replacing the Element:
Change the element every 500 hours or every oil change. Follow instructions supplied with the unit.

Replacement Parts List:

Part No.	Description	Qty.
CV820-02	Filter Bottom Assembly	1
CV820-09	Mounting Bracket, Stainless Steel	1

Optional Parts List:

CV7019	90_ Exhaust Elbow (see open system)	1
--------	-------------------------------------	---

For parts not listed, call Racor customer service: (800) 344-3286, 6 AM to 5 PM, Pacific Time.

SPECIFICATIONS are found on *Emission Control Systems* introduction page.

CV1000	FEATURES
<p><u>Basic Model</u> For 350-600 Horsepower rated engines. Unit flow capacity is 15 CFM.</p>	<ul style="list-style-type: none"> - For use with open systems only. - Adjustable body strap bracket. - Durable design and construction. - Replaceable filter media. - Removable oil collection sump. <p>Assembly is black anodized for long term corrosion resistance.</p>

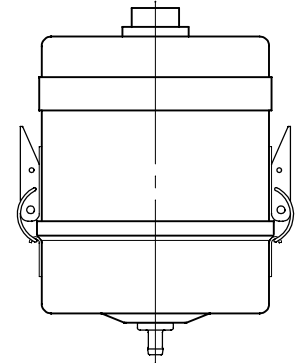

CV1000

Replacement Service Element

CV1000SK Service element. Order housing gasket below.

Installation Diagram / Dimensional Layout

Top View

Body is 8.14" (207 mm) diameter.
Either port may be Inlet / outlet:
1 1/4"-11 1/2 NPT female (SAEJ476).

Typical Open System installation. No scale.

.33" (8 mm) clearance required for fasteners.

3.35" (85 mm)

Quick release clamps retain collection sump.

Drain valve

Service:
On units that do not return the oil to the crankcase, check or drain the sump frequently until a routine service interval is established.

Replacing the Element:
Change the element every 500 hours or every oil change. Follow instructions supplied with the unit.

Replacement Parts List:

Part No.	Description	Qty.
CV1000-02	Filter Bottom Assembly	1
CV1000-04	Housing Gasket	1
CV1000-09	Mounting Bracket, Stainless Steel	1

Optional Parts List:

CV7018	90_ Exhaust Elbow	1
--------	-------------------	---

For parts not listed, call Racor customer service:
(800) 344-3286, 6 AM to 5 PM, Pacific Time.

Model Illustrations

CCV Style for Closed Systems

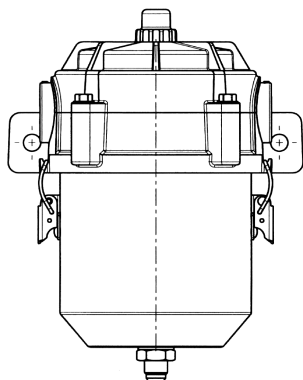

CCV4500

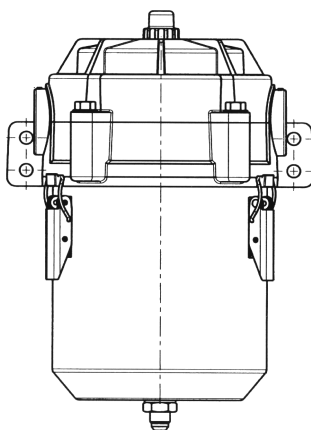

CCV6000

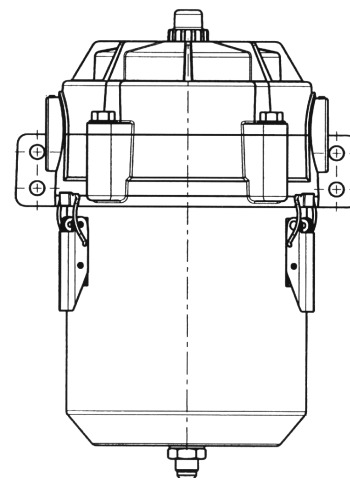

CCV8000

Special Notes

1. For additional information and availability, contact customer service at: (800) 344-3286, 6 AM to 5 PM, Pacific Time.
2. All CCV units are for Closed System applications only.

Specifications

BASIC MODELS		CCV4500	CCV6000	CCV8000
Engine Horsepower Rating, Max.	HP KW	0-400 0-298	400-800 298-597	800-1600 597-1,193
Inlet/Outlet Port Size		1 3/16" -12 SAE	1 5/8" -12 SAE	1 7/8" -12 SAE
Max. Air Flow*	CFM L/s	10 4.72	20 9.44	40 18.88
Filter Element		CCV55248-06 CCV55248-08	CCV55274-06 CCV55274-08	CCV55222-06 CCV55222-08
Height	in. mm	9.25 235.0	12.00 304.8	13.88 352.6
Diameter (depth)	in. mm	5.60 142.2	7.30 185.4	9.30 236.2
Width	in. mm	7.16 181.9	8.59 218.2	10.61 269.5
Weight (dry)	Lbs. kgs.	3.26 1.48	5.01 2.28	8.72 3.96
Operating Temperature		-40° / +240° F / -40° / +116° C		

* Values given are cubic feet per minute (CFM) and liters per second (L/s).
1. For horsepower rating consult your engine manual, engine manufacturer's agent or a Racor distributor.

Specifications are found on the Introduction page.

How to Order - The example below illustrates how the part numbers are constructed.

CCV4500	-08	L
Maximum flow rate is 10 CFM. This unit is for Closed System applications only.	<u>Specify</u> -06 for medium density media -08 for high density media (-08 is standard unless specified)	<u>Specify</u> L for inlet on left side R for inlet on right side

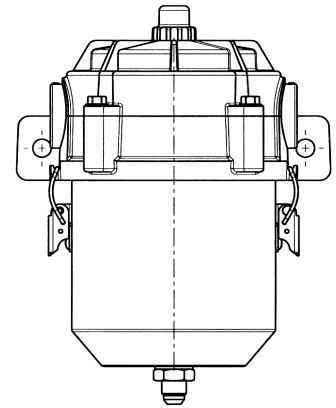

CCV4500

Replacement Service Elements

CCV55248-06	Service element, medium density
CCV55248-08	Service element, high density

Mounting Pattern / Parts List

Service:
The only routine maintenance for the Racor CCV system is replacement of the filter media. Change the element every 750 hours or every oil change. Follow instructions supplied with unit. Some variations in this occur, depending on load profile, engine wear condition, flow and aerosol mass, concentration of crankcase emissions, soot concentration, etc.

Parts List:

Part No.	Description	Qty.
Replacement Parts		
1	CCV55081 Bypass indicator replacement kit	1
2	CCV55246L Head assembly, with left side inlet	1
3	CCV55246R Head assembly, with right side inlet	1
4	CCV55249 Can assembly	1
5	CCV55279 1/4" MNPT drain check valve (shown)	1
	CCV55245 #4 SAE drain check valve	1
	CCV55022 Drain kit	1
6	CCV55248-06 Replacement element, medium density	1
	CCV55248-08 Replacement element, high density	1
Inlet and Outlet Fittings		
	CCV55250 1" OD hose barb to 1 3/16" SAE fitting	1
	CCV55251 3/4" OD hose barb to 1 3/16" SAE fitting	1
	CCV55280 1 1/4" OD hose barb to 1 3/16 SAE fitting	1
Hose and Fitting Kits		
	CCV55024 Hose kit, see CCV accessories page	1
	CCV55025 Hose kit, see CCV accessories page	1
	CCV55037 Hose kit, see CCV accessories page	1
	CCV55038 Hose kit, see CCV accessories page	1
Accessories		
	CCV55012 Remote crankcase pressure indicator	1
	CCV55039 3/4" by 3/4" by 3/4" OD hose barb tee fitting	1
	55021 Installation and Service instructions	1

No Scale

SPECIFICATIONS are found on Introduction page.

How to Order - The example below illustrates how the part numbers are constructed.

CCV6000	-08	L
Maximum flow rate is 20 CFM. This unit is for Closed System applications only.	<u>Specify</u> -06 for medium density media -08 for high density media (-08 is standard unless specified)	<u>Specify</u> L for inlet on left side R for inlet on right side

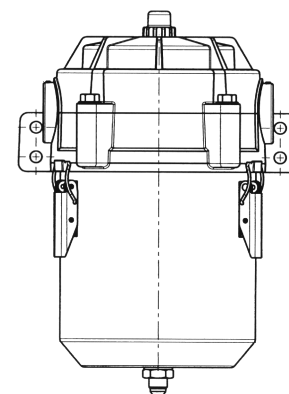

CCV6000

Replacement Service Element

- CCV55274-06** Service element, medium density
- CCV55274-08** Service element, high density

Mounting Pattern / Parts List

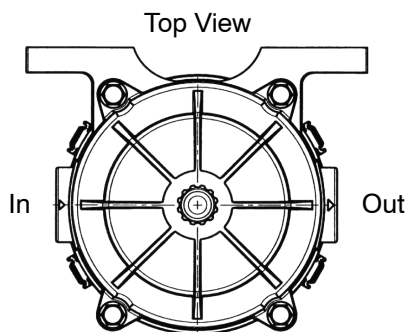

No Scale

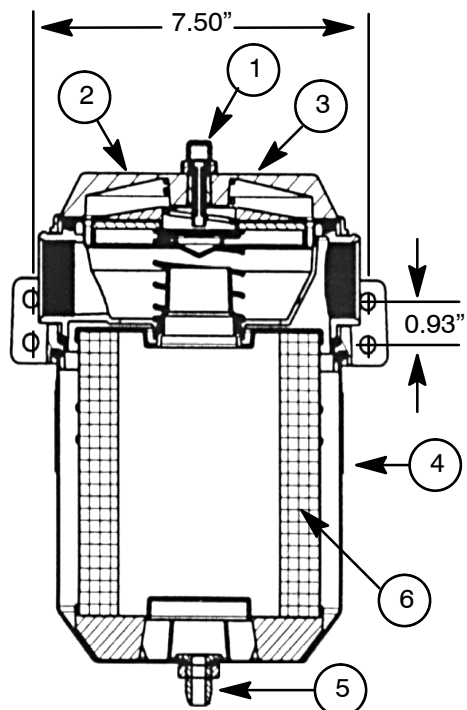

Service:

The only routine maintenance for the Racor CCV system is replacement of the filter media. Change the element every 750 hours or every oil change. Follow instructions supplied with unit. Some variations in this occur, depending on load profile, engine wear condition, flow and aerosol mass, concentration of crankcase emissions, soot concentration, etc.

Parts List:

Part No.	Description	Qty.
Replacement Parts		
1	CCV55081 Bypass indicator replacement kit	1
2	CCV55272L Head assembly, left side inlet	1
3	CCV55272R Head assembly, right side inlet	1
4	CCV55275 Can assembly	1
5	CCV55279 1/4" MNPT drain check valve (shown)	1
	CCV55245 #4 SAE drain check valve	1
	CCV55022 Drain kit	1
6	CCV55274-06 Replacement element, medium density	1
	CCV55274-08 Replacement element, high density	1

Inlet and Outlet Fittings

CCV55267	1 1/2" OD hose barb to 1 5/8" SAE fitting	1
CCV55268	1 1/4" OD hose barb to 1 5/8" SAE fitting	1

Hose and Fitting Kits

CCV55046	Hose kit, see CCV accessories page	1
CCV55047	Hose kit, see CCV accessories page	1
CCV55048	Hose kit, see CCV accessories page	1
CCV55049	Hose kit, see CCV accessories page	1

Accessories

CCV55012	Remote crankcase pressure indicator	1
CCV55040	1 1/4" by 1 1/4" by 1 1/4" OD hose barb tee fitting	1
CCV55020	1 1/2" by 1 1/4" Bushing Reducer	1
55021	Installation and Service instructions	

SPECIFICATIONS are found on Introduction page.

How to Order - The example below illustrates how the part numbers are constructed.

CCV8000	-08	L
Maximum flow rate is 40 CFM. This unit is for Closed System applications only.	<u>Specify</u> -06 for medium density media -08 for high density media (-08 is standard unless specified)	<u>Specify</u> L for inlet on left side R for inlet on right side

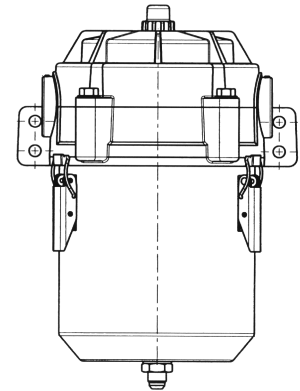

CCV8000

Replacement Service Element

CCV55222-06 Service element, medium density
CCV55222-08 Service element, high density

Mounting Pattern / Parts List

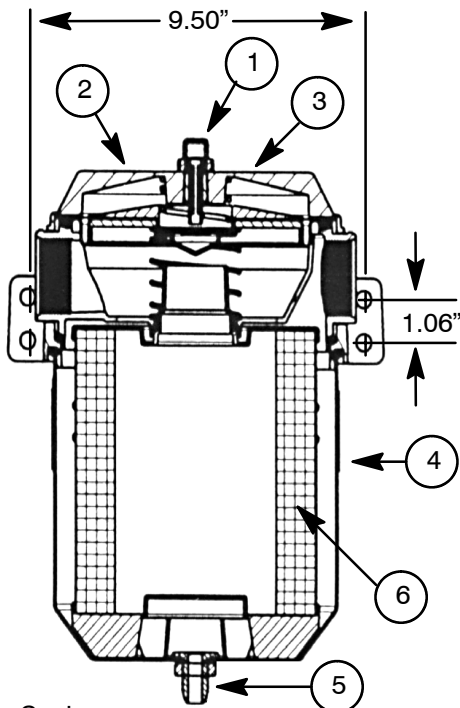
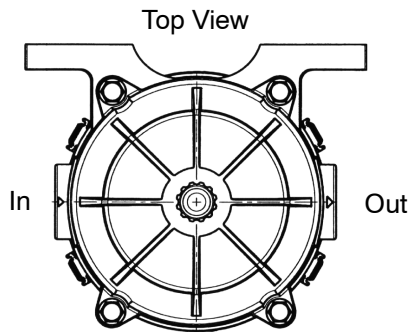

No Scale

Service:

The only routine maintenance for the Racor CCV system is replacement of the filter media. Change the element every 750 hours or every oil change. Follow instructions supplied with unit. Some variations in this occur, depending on load profile, engine wear condition, flow and aerosol mass, concentration of crankcase emissions, soot concentration, etc.

Parts List:

Part No.	Description	Qty.
Replacement Parts		
1	CCV55081 Bypass indicator replacement kit	1
2	CCV55220L Head assembly, left side inlet	1
3	CCV55220R Head assembly, right side inlet	1
4	CCV55223 Can assembly	1
5	CCV55080 3/8" MNPT drain check valve (shown)	1
	CCV55288 #8 SAE drain check valve	1
	CCV55071 Drain kit	1
6	CCV55222-06 Replacement element, medium density	1
	CCV55222-08 Replacement element, high density	1
Inlet and Outlet Fittings		
CCV55218	1 1/2" OD hose barb to 1 7/8" SAE fitting	1
Hose and Fitting Kits		
CCV55067	Hose kit, see CCV accessories page	1
CCV55068	Hose kit, see CCV accessories page	1
CCV55069	Hose kit, see CCV accessories page	1
Accessories		
CCV55012	Remote crankcase pressure indicator	1
CCV55041	1 1/2" by 1 1/2" by 1 1/2" OD hose barb tee fitting	1
CCV55020	1 1/2" by 1 1/4" Bushing Reducer	1
55021	Installation and Service instructions	

Hose Kits

(for models CV820 and CV1000 only)

Part No.	Description
CV1034	5 feet of 3/4" hose, fittings, clamps and ties
CV2034	7 1/2 feet of 3/4" hose, 3/4" Tee fitting, fittings, clamps and ties
CV1100	5 feet of 1" hose, fittings, clamps and ties
CV1114	5 feet of 1 1/4" hose, fittings, clamps and ties
CV2114	7 1/2 feet of 1 1/4" hose, 1 1/4" Tee fitting, fitting, clamps and ties
CV1112	5 feet of 1 1/2" hose, fitting, clamps and ties
CV1200	5 feet of 1 1/2" hose with 2" cuff, fitting, clamps and ties
CV1038	Air Box Drain Hose Kit, 8 feet of 3/8" hose, check valve, fittings, clamps & ties

Open System Exhaust Elbows

Part No.	Description
CV7022	1 1/4" 90 degree elbow for CV400 filter outlet and clamp
CV7019	1 1/2" 90 degree elbow for CV820 filter outlet and clamp
CV7018	2" 90 degree elbow for CV1000 filter outlet and clamp

Closed System Parts

Part No.	Description
CV6022	3/4" barbed fitting assembly for the dirty side of the air filter
CV6024	1" barbed fitting assembly for the dirty side of the air filter
CV6025	1 1/4" barbed fitting assembly for the dirty side of the air filter
CV8021	1" Pressure regulator

Closed System Kits - Dirty Side

Part No.	Description
CV6022CS	CV6022 fitting, 5 feet of 3/4" hose, fittings, clamps and ties
CV6024CS	CV6024 fitting, 5 feet of 1" hose, fittings, clamps and ties
CV6025CS	CV6025 fitting, 5 feet of 1 1/4" hose, fittings, clamps and ties

Closed System Kits - Clean Side

CV8021CS	CV8021 pressure regulator, 5 feet of 1" hose, clamps and ties
----------	---

Hose / Fitting Kits

Part No.	Description
<i>(for model CCV4500)</i>	
CCV55024	(1) 3/4" fitting, (1) 1" fitting, (1) 3/4" ID x 4' hose, (1) 1" ID x 4' hose, (4) clamps, and (4) ties.
CCV55025	(2) 1" fittings, (1) 1" ID x 8' hose, (4) clamps, and (4) ties
CCV55037	(1) 1 1/4" fitting, (1) 1" fitting, (1) 1 1/4" ID x 4' hose, (1) 1" ID x 4' hose, (4) clamps, and (4) ties.
CCV55038	(1) 3/4" fitting, (1) 1" fitting, (1) 3/4" ID x 6' hose, (1) 3/4" Tee fitting, (1) 1" ID x 4' hose, (8) clamps, and (8) ties.
<i>(for model CCV6000)</i>	
CCV55046	(2) 1 1/4" fittings, (1) 1 1/4" ID x 8' hose, (4) clamps, and (4) ties.
CCV55047	(2) 1 1/4" fittings, (1) 1 1/4" Tee fitting, (1) 1 1/4" ID x 10' hose, (8) clamps, and (8) ties.
CCV55048	(2) 1 1/4" fittings, (1) 1 1/2" ID x 4' hose, (1) bushing reducer, (1) 1 1/4" ID x 4' hose, (4) clamps, and (4) ties.
CCV55049	(2) 1 1/4" fittings, (1) 1 1/2" ID x 5' hose with 2" cuff, (1) bushing reducer, (1) 1 1/4" ID x 4' hose, (4) clamps, and (4) ties.
<i>(for model CCV8000)</i>	
CCV55067	(2) 1 1/2" fittings, (1) 1 1/2" ID x 10' hose, (1) bushing reducer, (4) clamps, and (4) ties.
CCV55068	(2) 1 1/2" fittings, (1) 1 1/2" Tee fitting, (1) 1 1/2" ID x 12' hose, (2) bushing reducers, (8) clamps, and (8) ties.
CCV55069	(2) 1 1/2" fittings, (1) 1 1/2" ID x 5' hose with 2" cuff, (1) 1 1/2" ID x 5' hose, (4) clamps, and (4) ties.

Tap Sleeves

Part Number	Outlet Diameter (A)	Length (B)	Hose Barb (C)
CCV30100	3.00"	5.00"	1.00"
CCV40100	4.00"	5.00"	1.00"
CCV50125	5.00"	6.00"	1.25"
CCV60125	6.00"	6.00"	1.25"

Note: CCV60125 includes 1 1/4" x 1 1/2" bushing (connects to 1 1/2" ID hose)

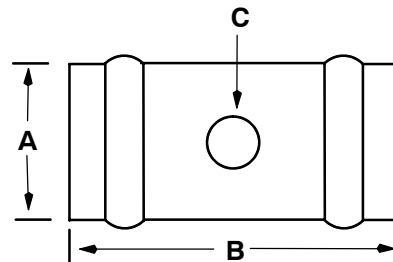

Marine Air Filters - for additional information, see section 2.

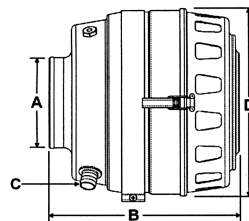

Marine Air Filter Model	Outlet Diameter (A)	Length (B)	Hose Barb (C)	Filter Outside Diameter (D)	Replacement Element Part Number
AF M408512	4.00"	12.50"	1.00"	9.59"	AF M8040
AF M501012	5.00"	12.50"	1.00"	11.14"	AF M8050
AF M601212	6.00"	12.50"	1.25"	13.51"	AF M8060

Note: AF M601212 includes 1 1/4" x 1 1/2" bushing (connects to 1 1/2" ID hose)

Racor Products

Section 8 Air Filters

- Introduction
- On-Highway
- Transit Filters
- Replacement Marine Air Filters
- Accessories



Selection Information

General

Racor Long Life Air Filters feature a multi-stage, depth media treated with a specially formulated compound. Long Life filters are **not** cleanable and can still:

- Hold up to 8 times more contaminants than conventional paper filters.
- Provide a minimum of twice the service life of conventional paper filters.
- Increase fuel economy due to lower initial restriction.
- Prevent corrosion by repelling water.

Twice-the-life Guarantee

Parker Hannifin Corporation, Racor Division guarantees that each new Long Life Air Filter Element will provide a minimum of Twice-The-Life service compared to a conventional pleated paper-type air filter element, if it is installed properly and serviced according to the manufacturer's recommended procedures.

If any Long Life Air Filter element fails to provide at least Twice-The-Life service of the conventional pleated paper-type air filter element that the user has been using, Racor will replace the air filter, **free of charge.** (See Accessories section for details).

When to Change the Long Life Filter

The only reliable way to tell when the filter is 'used up' is to measure the restriction. An inexpensive restriction gauge, provides a reliable restriction reading at all times.

A word about exhaust smoking. There should be little, if any, significant smoke, black or white coming from the exhaust pipe of a properly warmed engine. A lot of white smoke means that there is excess, unburned fuel being pushed through the system. Black smoke indicates incomplete combustion, typically from a restricted air intake. Check for air cleaner and related component blockages.

Superior Performance

The condensed report below presents results conducted in accordance with the SAE J726 JUN 87 Air Cleaner Test Code. The results provide airflow pressure drop, efficiency and dust holding capacity using a Long Life, N0387 air filter element installed in a P15-0862 housing. Clean element pressure drop and restriction, initial, incremental and cumulative efficiency, and dust holding capacity were measured. The efficiency/dust holding capacity test was conducted at 1100 SCFM (25°C, 100 kPa) using AC FINE Test Dust at a concentration of 0.25 g/m³ air (0.007 g/ft³ air).

The test was conducted by Southwest Research Institute, an independent scientific laboratory. All of the data below except for the far right column is an excerpt from the Southwest Research Institute test results.

Dust Holding Capacity (grams)	Pressure Drop, (in. H ₂ O)	0.5 Micron % Efficient	5 Micron % Efficient	10 Micron % Efficient	≥ 15 Micron % Efficient	Average % Efficient	Average % Efficient
8	5.2	99.82	93.50	99.87	100	97.36	99.20
111	5.8	99.55	97.98	99.87	100	99.15	99.73
228	6.6	99.66	98.67	99.66	99.98	99.36	99.77
413	8.3	99.94	99.98	99.94	99.98	99.97	99.97
530	9.9	99.99	99.92	99.96	100	99.96	99.98
614	12.3	99.40	99.95	99.96	100	99.97	99.99
756	18.5	99.90	99.90	99.96	99.96	99.94	99.95
805	23.8	99.98	99.92	99.66	100	99.87	99.98
Dust Type		Fine	Fine	Fine	Fine	Fine	Coarse

AC FINE Test Dust was used in the actual test because it represents the most rigorous conditions. The far right column is extrapolated data weighted for AC COARSE Test Dust which is more representative of 'over-the-road' conditions.

SELECTION

Refer to the Index page for your equipment classification and applicable cross reference table.

For additional information, call your Racor dealer or call Racor customer service at (209) 521-7860 or (800) 344-3286, 6:00 AM to 5:00 PM, Pacific Time, or e-mail us from our website www.parker.com/racor.

Cross Reference Chart for Popular On-Highway Air Filter Elements

Long Life O/I	Long Life I/O	Baldwin	Donaldson	Fleetguard	Fram	Wix
AFN0391	AFN0491	PA2501	P12-9396	AF954M	CA3517	42610
AFN0581	AFN0681	PA2631	P14-2100	AF1817M	CA6326	46860
	AFT2555	PA2571	P15-1097	AF1875M	CA3691	42459
AFN0387		PA2705	P15-3551	AF1968M	CA3990	46883
	AFT2079	PA2312	P18-1007	AF853	CA1581	42618
AFN1792	AFN2581	PA2317	P18-1008	AF852	CA598	42961
	AFN2595	PA2357	P18-1009	AF865	CA596	42661
AFN1738		PA1980FN	P18-1013	AF478K	CAK558	42943
AFN1752		PA2525	P18-1015	AF982	CA1599	42491
	AFN2095	PA2493	P18-1016	AF1616	CA2539	42941
AFN1517		PA2596	P18-1030	AF1815	CA2576	46280
AFN1766		PA2333	P18-1099	AF872	CA592	42960
AFN1788		PA2394	P18-1185	AF871	CA1505	42698
	AFN2729	PA2729	P52-1598	AF4664	CA6926	46844
	AFN1366	PA2521	P18-1028	AF979	CA1596	42243
AFN0191		PA2500	P12-9472	AF1837	CA3518	42611
AFN1545		PA2661	P18-1096	AF1943M	CA3863	46596
	AFN2530	PA2439	P18-1004	AF911	CA1550	42636
	AFN2520	PA2438	P18-1005	AF910	CA1551	42635

O/I = Outside In flow

I/O = Inside Out flow

Engine Air Filtration

Transit Filters

Cross Reference Chart for Popular Transit use Air Filter Elements

Long Life O/I	Long Life I/O	AC	Air Refiner	Baldwin	Donaldson	Fleetgrd
AFT9029		PC185 A1035C	ARM2301	PA2474	P15-1951	AF1798
AFT1766		A1081C	ARM11-8047	PA2333	P18-1099	AF872
	AFS2595 AFT2595	A579C	ARM11-6880	PA2357	P18-1009	AF865
AFT1379	AFT2079	A726C A590C	ARM11-7797	PA2312	P18-1007	AF853
AFT1780	AFT2780	A774C	ARM12-4490	PA2515	P15-3973	AF995M
	AFT2555	A850C	ARM13-3754	PA2571	P15-1098	AF4782
	AFT2760		ARM15-3972	PA3573	P15-3972	AF4784
AFT1850			ARM52-2874	PA2839	P77-1582	AF1812
AFT1778			ARM11-8039	PA2394	P18-1185	AF871

O/I = Outside In flow

I/O = Inside Out flow

Replacement Filters for Marine Air Filter/Silencer Will-Fit Elements

Racor now offers replacement filters for AirSep type marine applications. These filters are direct replacements for the intake air filter portion of competitive air filters/silencers. Also available is the replacement element for the Vacuum Limiter Air Separator.

The filter media for all replacement filters is an oil-impregnated cotton gauze and is sandwiched between pleated, epoxy-coated aluminum wire-mesh with molded polyurethane sealing surfaces. **This product is cleanable and must be oiled before re-using.**

Walker Part Number	Racor Part Number	Dimensions (in inches) (D x H x d)
CD169	N/A	16 x 16 x 16
CD170	AF M8145	10 x 8 x 10
CD173	N/A	7.5 x 5 x 7.5
CD174	AF M8121	7.5 x 6 x 7.5
CD175	AF M8122	7.5 x 7 x 7.5
CD176	N/A	7.5 x 8 x 7.5
CD177	AF M8124	7.5 x 9 x 7.5
CD178	AF M8126	7.5 x 10 x 7.5
CD180	AF M8010	3" Air Separator Element
CD181	AF M8146	10 x 10 x 10
CD182	AF M8143	10 x 12 x 10
CD183	AF M8153	12 x 12 x 12
CD184	AF M8037	9 x 14 x 6.875
CD185	N/A	10 x 14
CD186	AF M8152	12 x 7 x 12
CD187	AF M8155	12 x 8 x 12
CD189	N/A	12 x 14 x 12
CD190	AF M8026	7.5 x 10 x 5.125
CD194	AF M8021	7.5 x 6 x 5.125
CD195	AF M8025	7.5 x 8 x 5.125
CD196	AF M8034	9 x 9
CD197	AF M8033	9 x 12
CD200	AF M8134	9 x 9 x 9
CD201	AF M8133	9 x 12 x 9
CD202	AF M8141	10 x 6 x 10
CD203	AF M8151	12 x 6 x 12
CD204	AF M8156	12 x 10 x 12
Detroit Diesel PN.		
23508033	AF M8033	12" Filter
23508034	AF M8034	9" Filter

AF M81xx Series

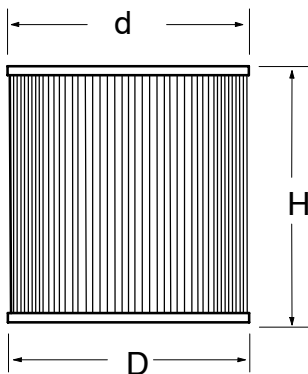

AF M80xx Series

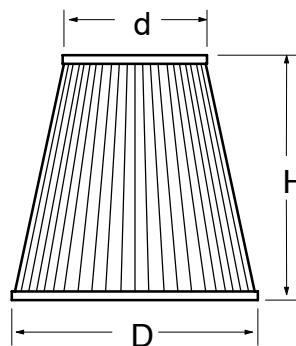

DDC Marine Intake Silencer Foam Wrap

Part Number	Quantity
AF M8001	6 per package

Foam cover improves filtration and further reduces noise on Detroit Diesel style intake silencers

Air Service Restriction Indicator

When should you change your Long Life filter?

Long Life filters do a great job of stopping dirt, soot and water before they can contaminant your engines. Such a great job that a filter that has been in use for awhile will look very dirty like it is already clogged. But that just means it is doing its job. Remember that every filter change is an opportunity to contaminant your engine, so unnecessary changes should be avoided. The only way to tell when the filter is 'used up' is to measure the restriction. Your shop has equipment for precise measurement during service stops. An inexpensive restriction gauge, will give your drivers a restriction reading your shop can verify when they get back in.

Part Number	Scale/Description	Case Qty.
AF H8500	20 in.H ₂ O	1
AF H8501	25 in.H ₂ O	1
AF H8502	30 in.H ₂ O	1
AF H8510	20 in.H ₂ O, Dash Mount	1
AF H8511	25 in.H ₂ O, Dash Mount	1
AF H8512	30 in.H ₂ O, Dash Mount	1
AF H8520	20 in.H ₂ O, Electric	1
AF H8521	25 in.H ₂ O, Electric	1
AF H8522	30 in.H ₂ O, Electric	1
AF H8530	20 in.H ₂ O, Remote Mount	1
AF H8531	25 in.H ₂ O, Remote Mount	1
AF H8532	30 in.H ₂ O, Remote Mount	1

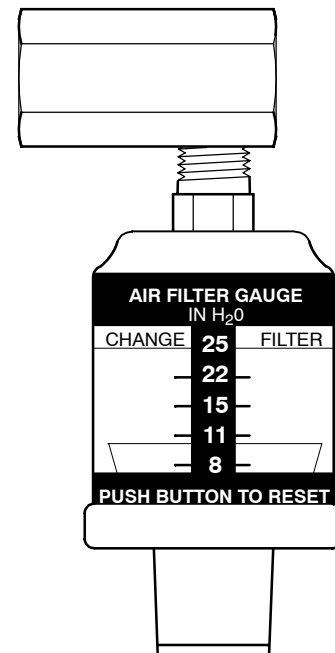

Racor Products

Section 9 Additives

- Selection
- Introduction
- Conditioner Plus+
- Biocide
- Winter Plus+
- Gasoline Conditioner +
- Oil Treatment
- Coolant Treatment



Help & General
Information

General

The *all-new* Racor additive line includes products for all climates and seasons. The products include a biocide: a year-'round conditioner and winter additive for diesel engines: a year-'round gasoline conditioner; lube oil treatment and coolant treatment. Racor additives mix well with fuels are not removed by fuel filters.

There are several convenient sizes: our 16 oz. bottle that makes measuring quick and easy, and 1 and 2.5 gallon bottles are convenient for larger fuel tanks. The high concentration of active ingredients in Racor additives allows for higher treatment rates.

Exhaust Smoke

In a properly warmed engine, there should be little, if any, significant smoke, black or white, coming from the exhaust pipe. Black smoke indicates incomplete combustion, typically from a dirty air filter, poor injection (a leaking or dribbling injector), engine overloading or the air intake temperature is too high (poor density).

White smoke means that there is excess, unburned fuel being pushed through the system or that there is water ingestion (leaky gasket or crack in cylinder head or case).

Blue smoke means the engine is burning crankcase oil. Causes can be worn valve guides/stems, broken or worn piston rings, a leak in the turbo or too much oil in the crankcase.

1. FOR OPTIMUM ENGINE PROTECTION AND EFFICIENCY, USE A FUEL AND OIL CONDITIONER ALL THE TIME.
2. FOR OPERATIONS IN COLD CLIMATES WHERE DIESEL FUELS MAY GEL, USE DIESEL WINTER PLUS+ WITH DIESEL CONDITIONER PLUS+.
3. FOR OPERATIONS IN HIGH HUMIDITY AREAS OR WHERE WATER IN FUEL TANK BOTTOMS IS EVER-PRESENT, USE DIESEL FUEL BIOCIDES WITH DIESEL CONDITIONER PLUS+.
4. FOR OPTIMUM COOLANT SYSTEM PROTECTION AND LUBRICATION, USE COOLANT TREATMENT.

Using this information, select a product from the following pages.

Container Illustrations Not to Scale

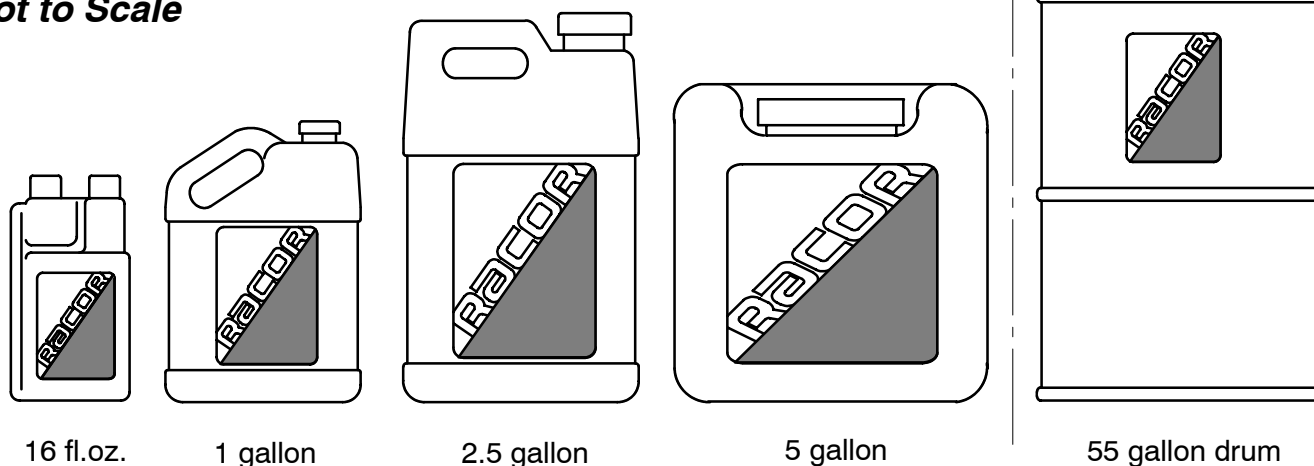

Special Notes

1. All sizes, 5 gallons and under, are plastic containers. Fifty-five (55) gallon drums are steel.
2. For additional information and availability, contact customer service at: (800) 344-3286, 6 AM to 5 PM, Pacific Time.

Specifications

Products	Conditioner Plus+	Diesel Fuel Biocide	Winter Plus+	Gasoline Treatment	Lube Oil Treatment	Coolant Treatment
Treatment Ratio	1 fl.oz./ 20 gallons	1 fl.oz./ 80 gallons	1 fl.oz./ 8 gallons	1 fl.oz./ 20 gallons	1 fl.oz./ 1 pint	1 fl.oz./ 1/2 gallon
Available Sizes, Case Dimensions, Quantity per Case and Weights						
16 fl.oz. Treats: 13.5 X 8.5 X 9 12/case 14 lbs.	320 gal.	1280 gal.	128 gal.	320 gal.	8 qts.	8 gal.
1 gallon Treats: 14.5 X 10 X 11 4/case 32 lbs.	2560 gal.	10,240 gal.	1024 gal.	NA	16 gal.	NA
2.5 gallon Treats: 15.5 X 10 X 15 2/case 45 lbs.	6400 gal.	N/A	2560 gal.	6400 gal.	NA	NA
5 gallon Treats: 10 X 11 X 14 1/case 39 lbs.	N/A	51,200 gal.	N/A	N/A	N/A	N/A
55 gallons Treats: 24 dia. X 37 1 drum, 450 lbs.	140,800 gal.	563,200 gal.	56,320 gal.	140,800 gal.	880 gal.	NA

Part Numbers / Sizes / Treatment

Part No.	Size	Treatment	Case Qty.
ADT 1116	16 fl.oz.	320 gallons	12
ADT 1201	1 gallon	2560 gallons	4
ADT 1325	2.5 gallons	6,400 gallons	2
ADT 1555	55 gallons	140,800 gallons	1 drum
RK 21644	Pour spout extension (for 16 oz. bottle only)		1

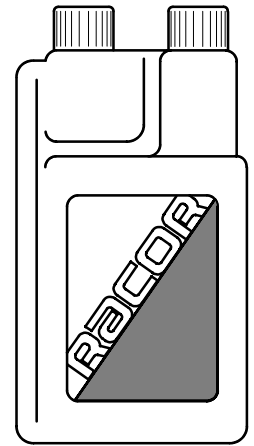

16 fl. oz. shown

Information about Racor Diesel Fuel Conditioner Plus+

During normal use, a diesel engine is subjected to a variety of loads under some of the most unusual conditions and in all types of weather. The performance of the engine is greatly determined by the quality of fuel it burns. The best way for the operator to ensure that quality fuel is being used is to supplement it with an additive. Racor's Diesel Fuel Conditioner Plus+ contains all the ingredients, *and in the right proportions*, to provide the right protection and maintain fuel quality.

Racor Diesel Conditioner Plus+ is a multi-functional diesel fuel additive for all season use. Its formulation contains a cetane improver which enhances power delivery, starting, and helps engines run smoother and quieter. Racor Diesel Conditioner Plus+ passes the Cummins L10 superior rating for detergency and the Scruffing BOCLE test for lubricity as demonstrated in low and high sulfur fuel. Use with Racor Diesel Winter Plus+ in cold weather and Racor Diesel Biocide in warm climates to achieve maximum performance benefits throughout the year.

Contains lubricity additives to reduce friction and improve fuel economy

Lubricity additives, more than ever, are needed in today's fuels. By including this important ingredient, friction is significantly reduced, therefore so is the operating temperature of the engine. When an engine runs cooler, it lasts longer and runs more efficiently.

Keeps injectors clean and dissolves gums and varnishes

Racor's Conditioner Plus+ wouldn't be much of a conditioner if it didn't do a little clean-up work too. A detergency additive (the strongest in the market) was selected that could actually do some good to clean up engines and at the same time keep them that way. The fuel then acts as the cleaning agent to remove the buildup of gums, varnishes and other deposits. Clean injectors stop rattling and start providing the spray pattern designed into them at the factory. Now more efficient combustion can take place, improving economy and reducing emissions.

Stabilizes fuel during prolonged storage and prevents corrosion

A very important component of *Diesel Conditioner Plus+* is the fuel stabilizer. During prolonged storage, fuel tends to oxidize and degrade. The fuel quality can actually deteriorate to such a point that the engine is easily fouled with contaminant by-products and water. The fuel stabilizer maintains the fuel quality (resistance to degradation) so that it is not susceptible to deterioration. The potential for corrosive elements is also eliminated by providing a protective coating to bare metal surfaces, keeping water away.

Alcohol free

Racor doesn't add alcohol to our additives. In fact, we add a compound that actually causes water to coalesce (make larger droplets) so your Racor Fuel Filter/Water Separator becomes much more efficient. Alcohol is damaging to many of the components in fuel systems and is not recommended by most engine manufacturers.

Use Instructions

This product is most effective when added to the fuel tank, just prior to fueling. *Initial Treatment:* Add 2 oz. of Racor Diesel Conditioner Plus+ for every 20 gallons of fuel (approximately 300 PPM) the first time the product is used and/or every time the operator determines the injectors require cleaning. *Maintenance Treatment:* Add 1 oz. for every 20 gallons of fuel (approximately 150 PPM) at the above treat ratio.

Handling and Storage

Racor Diesel Conditioner Plus+ may be stored at up to 120°F (49° C). Viscosity of the additive is low enough to provide good handling under ambient conditions.

Part Numbers / Sizes / Treatment

Part No.	Size	Treatment	Case Qty.
ADT 2116	16 fl.oz.	1,280 gallons	12
ADT 2201	1 gallon	10,240 gallons	4
ADT 2405	5 gallons	51,200 gallons	1
ADT 2555	55 gallons	563,200 gallons	1 drum
RK 21644	Pour Spout Extension (for 16 oz. bottles only)		1

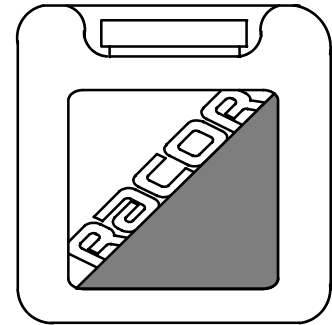

5 gallon shown

Information about Racor Diesel Fuel Biocide

Water is a heavier fluid than diesel fuel and will settle to the bottom of the fuel tank. At the layer where water and diesel separate, airborne microorganisms introduced through water condensation and poor fuel handling practices settle and grow. They live in the water and feed on the hydrocarbons in the fuel. In an ideal habitat, they can double their population every 20 minutes. The colony could grow so large as to completely contaminate the fuel tank, foul the fuel gauge sender and quickly plug the fuel filter. Microorganisms also produce waste acids that attack metal surfaces, resulting in forms of loose particles of iron oxide.

Racor's Diesel Fuel Biocide is a highly effective additive for use in controlling the growth of bacteria and fungi in all diesel fuel grades, especially those in use for marine applications. This formula also contains a non-foaming agent and a corrosion inhibitor to protect metallic surfaces.

EPA Registration No. 1448-172-47099, EPA Establishment No. 072342-CA-001

Racor's Biocide is registered with the U.S. Environmental Protection Agency. If a biocide product doesn't have an EPA registration number, it is in violation of federal regulatory controls. Racor's Biocide is an extremely effective and powerful product. It must be used in accordance with printed regulations and stored as directed.

Kills more forms of algae and bacteria and is non-selective

Racor's Biocide kills more forms of biological contamination than any other brand and is non-selective when doing so. In other words, this formula isn't formulated to kill some varieties or strains but to kill more and any that feed on fuel hydrocarbons.

Both water and fuel soluble and mixes at all temperatures

Racor Biocide not only kills microorganisms in the water but also kills them if they are in the fuel -*it's both water and fuel soluble!* As long as fuel can flow, Racor Biocide will mix more effectively and more thoroughly to provide protection in all temperatures.

Concentrated, time-release formula kills faster and longer

While some anti-foulants take time to kill microorganisms, Racor's Biocide additive works within 12 hours of application (other brands take up to 72 hours) and keeps on working longer than other brands. Another benefit is that regeneration is halted. Microbes are killed and that's final. There are no survivors to restart, or *regenerate*, the cycle.

Alcohol free

Alcohol is damaging to many of the components in fuel systems and is not recommended by most engine manufacturers. Racor doesn't add alcohol to our additives. Alcohol is damaging to many of the components in fuel systems and is not recommended by most engine manufacturers.

Use instructions

Initial treatment: add 1 oz of Racor Diesel Biocide for every 40 gallons of diesel fuel. *Maintenance treatment:* add 0.5 oz for every 40 gallons of diesel fuel.

NOTE: DEAD MICROBIAL GROWTH WILL EVENTUALLY FALL INTO THE FUEL STREAM AND WILL CAUSE FUEL FILTERS TO PLUG RAPIDLY. CARRY SPARE ELEMENTS WHEN USING RACOR BIOCIDES.

Part Numbers / Sizes / Treatment

Part No.	Size	Treatment	Case Qty.
ADT 4116	16 fl.oz.	128 gallons	12
ADT 4201	1 gallon	1024 gallons	4
ADT 4325	2.5 gallons	2560 gallons	2
ADT 4555	55 gallons	56,320 gallons	1
RK 21644	Pour Spout Extension (for 16 oz. bottle only)		1

Note: This special product activates only after being mixed with diesel fuels. When not in use, store Racor Winter Plus+ above 32°F (0°C).

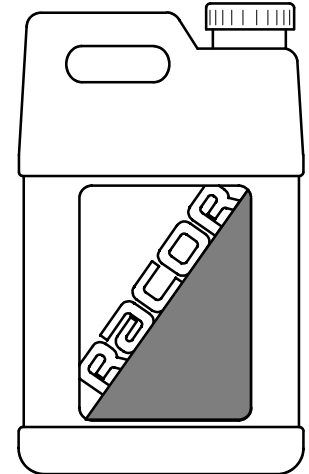

2.5 gallon shown

Information about Racor Diesel Winter Plus+

When diesel fuels are chilled an unusual problem arises: *waxing*. At about 10°F. and colder, fuel becomes thick and cloudy because paraffin wax crystals (and suspended water ice crystals) take shape. This is known as the fuel *cloud point* (so named because the fuel begins to cloud or haze). Paraffin wax actually traps the fuel within the crystalline structure, reducing the ability to flow. Fuel filters gradually become plugged to the point of starving the engine of fuel. (If the fuel was chilled another ten degrees it would freeze completely and no longer flow! This is known as the fuel *pour point*).

Racor's Diesel Winter Plus+ is formulated to combat fuel icing and wax buildup. It retards ice formation and coats the system with a slip agent so ice will not cling and form plugs. Its formulation contains a cetane improver which enhances power delivery, starting, and helps engines run smoother and quieter.

Inhibits waxing, icing and gelling

Racor's Winter Plus+ modifies the structure of wax crystallization so that they cannot trap the fuel. This effect lowers the pour point of No.2 diesel fuel and provides protection down to -32°F. Engine starting is easier and continued operation in chilling climates is enhanced.

Stabilizes fuel during prolonged storage and prevents corrosion

A very important component of *Winter Plus+* is the fuel stabilizer. During prolonged storage, fuel tends to oxidize and degrade. The fuel quality can actually deteriorate to such a point that the engine is easily fouled with contaminant by-products and water. The fuel stabilizer maintains the fuel quality (resistance to degradation) so that it is not susceptible to deterioration. The potential for corrosive elements is also eliminated by providing a protective coating to bare metal surfaces, keeping water away.

Prevents corrosion and is alcohol free

Another component of Racor's Winter Plus+ is a corrosion inhibitor that protects bare metal surfaces, protecting the fuel from further contamination. Alcohol is damaging to many of the components in fuel systems and is not recommended by most engine manufacturers. Racor doesn't add alcohol to our additives. In fact, we add a compound that actually causes water to coalesce (make larger droplets) so your Racor Fuel Filter/Water Separator becomes much more efficient.

Use Instructions

This product is most effective when added to the fuel tank, just prior to fueling. Do not add this product to fuel that is already gelled in the tank. *Treatment Ratio:* One (1) oz. treats 8 gallons of diesel fuel. Typical treat level is 530 PPM.

Additional Instructions

1. This product activates when mixed with diesel fuel. When not in use, store product above 32° F (0° C).
2. For extended cold weather operations, a diesel fuel heater may be needed as well. Refer to Section 1 for Racor Diesel Fuel Heaters.

Part Numbers / Sizes / Treatment

Part No.	Size	Treatment	Case Qty.
ADT 5116	16 fl.oz.	320 gallons	12
ADT 5325	2.5 gallons	6400 gallons	2
ADT 5555	55 gallons	140,800 gallons	1
RK 21644	Pour Spout Extension (for 16 oz. bottle only)		1

Note: Store product in a cool and dry location away from heat.

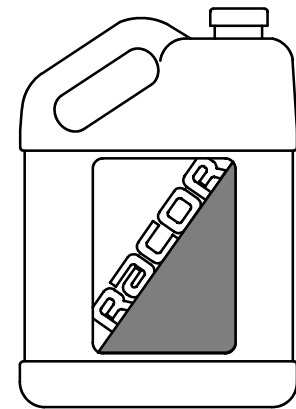

1 gallon shown

Information about Racor Gas Conditioner Plus+

Racor Gasoline Conditioner Plus+ enhances engine performance by cleaning the fuel injectors or carburetor and intake systems, providing better combustion and therefore better fuel economy. It can be used with all types of gasoline engines, systems and all gasoline blends. For the best protection, use this product regularly.

Cleans fuel injectors and carburetors

Racor's Gasoline Conditioner Plus+ contains many fuel modifiers, providing a continuous cleaning action which inhibits and removes carbon buildup and the accumulation of deposits. *Gasoline Conditioner Plus+* cleans fuel injectors thereby maintaining a proper spray pattern, improving efficiency and reducing injector noise. Engine starting is easier and continued operation in all kinds of weather is enhanced.

Stabilizes fuel during prolonged storage

An important component of *Gasoline Conditioner Plus+* is the fuel stabilizer. During prolonged storage, fuel tends to oxidize and degrade. The fuel quality can actually deteriorate to such a point that the engine is easily fouled with contaminant by-products and water. The fuel stabilizer maintains the fuel quality (resistance to degradation) so that it is not susceptible to deterioration.

Prevents corrosion and is alcohol free

The potential for corrosive elements is also eliminated by providing a protective coating to bare metal surfaces, keeping water away. Alcohol is damaging to many of the components in fuel systems and is not recommended by most engine manufacturers. Racor doesn't add alcohol to our additives.

Use Instructions

This product is most effective when added to the fuel tank, just prior to fueling. Additive dosage will vary, depending on the end user's desire to keep the system clean or to improve performance. Recommended standard dosage is one (1) oz. of Racor Gasoline Conditioner Plus+ for every 20 gallons of fuel.

Additional Instructions

1. Store this product away from heat or flame in a cool, dry location, away from the reach of children.

Part Numbers / Sizes / Treatment

Part No.	Size	Treatment	Case Qty.
ADT 7116	16 fl.oz.	2 gallons	12
ADT 7201	1 gallon	16 gallons	2
ADT 7555	55 gallons	880 gallons	1
RK 21644	Pour Spout Extension (for 16 oz. bottle only)		1

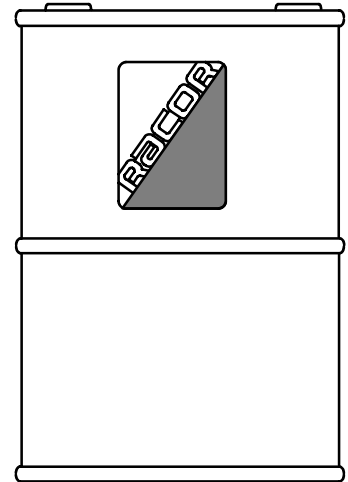

55 gallon drum shown

Information about Racor Lube Oil Treatment

Racor Lube Oil Treatment is a fluorocarbon additive which contains an advanced, highly effective polymer lubricant. It provides a superior thin coating to protect precision engine parts and does not contain PTFE or Teflon* which have been known to fall from suspension and clog precision engine components. Many of today's leading oil companies are now slowly making way to the retail counters with their own types of treatments but only Racor has sourced an independent research laboratory that has developed this unique product and only Racor may offer it.

Reduces engine wear, noise and heat, increasing power, mileage and engine life

Racor's Lube Oil Treatment contains a proprietary ingredient, not available in any other competitive product, that offers superior lubrication even with standard engine oils. A protective barrier reduces friction, allowing parts to move smoothly. Reducing friction also reduces noise and heat that allows engines to run quieter and cooler. With continuous use at every oil change, you can assure your engine performance and extend its useful service life.

Compatible with all motor oils, and with diesel or gasoline engines

This product works in any grade of motor oil, both petroleum and synthetic, and in any kind of an engine. Put Racor's Lube Oil Treatment to the test in all of your engines.

Reduces harmful emissions and controls foaming

Racor's Lube Oil Treatment contains modifiers that stabilize oil reactions to crankcase heat and pressure to limit harmful emissions usually lost at crankcase breathers or into clean air intakes. Anti-foaming ingredients control crankcase lubrication system foam accumulation.

Use Instructions

This product may be added to engine oil at any time. *Treatment Ratio:* two (2) oz. treat one quart of lube oil. Recommended for use after every four (4) oil changes, and may be used as often as every oil change.

Additional Instructions

1. This product is most effective with continued use.
2. Blend using conventional equipment and methods for blending finished fluids. Do not heat over 140°F (60°C) for prolonged periods to avoid possible release of alkyl mercaptans and/or hydrogen sulfide.

*Teflon, is a registered trademark of the E.I. DuPont de Nemours & Co.

Part Numbers / Sizes / Treatment

Part No.	Size	Treatment	Case Qty.
ADT 8116	16 fl.oz.	8 gallons	12
RK 21644	Pour Spout Extension (for 16 oz. bottle only)		1
Use this product directly with your existing mixture of coolant (anti-freeze) and water. For use with ethylene glycol-based anti-freeze/coolant only; do not use with EHA or Dexcool type systems. Always consult your dealer or owner's manual for warranty restrictions. (1 fl.oz treats 1/2 gallon or 2 quarts or 4 pints)			

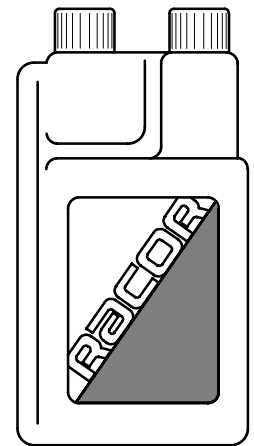

16 fl. oz. shown

Information about Racor Coolant Treatment

Racor's Coolant Treatment is a combination corrosion inhibitor and iron oxide/scale dispersant. Its unique formulation protects all types of metals, including aluminum, in the cooling system.

The advantage of using Racor Coolant Treatment over coolant system spin-on type applicators is that the mixture is correct at treatment time. Spin-on types tend to 'over-charge' the cooling system, becoming quite toxic. This mixture would then require a caustic flush and the waste would need to be disposed in accordance with local regulations. This could be very costly to perform, especially on a fleet of vehicles.

Meets all engine manufacturer's requirements for diesel and gasoline engines

An important feature of the Racor product is that it is acceptable for use with all engines utilizing ethylene glycol-based systems -an important point when using a coolant treatment. Racor Coolant Treatment is specially formulated to work with all types of cooling systems and that includes marine 'closed-type' cooling systems. It is able to maintain maximum efficiency in heat transfer to keep your engine running cooler. When an engine runs cooler, it lasts longer and runs more efficiently.

Contains a corrosion inhibitor, water pump lubricator and an anti-foaming agent

Racor's Coolant Treatment wouldn't be just another product on the shelf if it didn't do a little work too. A corrosion inhibitor was selected that could actually do some good to coat and protect the inside of your engine and coolant system components, creating a barrier to scale deposits and rust. A water pump lubricator maintains smooth operation by enhancing seal efficiency and protecting rubber and polymers. The anti-foaming agent keeps the coolant mixture from excessive foaming due to the turbulence within the cooling cycle. This maintains better coolant consistency for the best heat transfer.

For maximum protection, always treat a fresh mixture of engine coolant with Racor Coolant Treatment.

Note: Racor Coolant Treatment can be added to water-only "closed-type" cooling systems for control of scale deposits, rust, water pump/seal maintenance, and anti-foaming characteristics.